

Datasheet

Advantech

AIMB-278 B1

Mini-ITX Motherboard 12th/13th/14th Gen Intel® Core™ Processor LGA1700

FORTEC
UNITED STATES



FORTEC
INTEGRATED



FORTEC
UNITED KINGDOM



The information contained in this document has been carefully researched and is, to the best of our knowledge, accurate. However, we assume no liability for any product failures or damages, immediate or consequential, resulting from the use of the information provided herein. Our products are not intended for use in systems in which failures of product could result in personal injury. All trademarks mentioned herein are property of their respective owners. All specifications are subject to change without notice.

AIMB-278 B1

Mini-ITX Motherboard 12th/13th/14th Gen Intel® Core™ Processor LGA1700

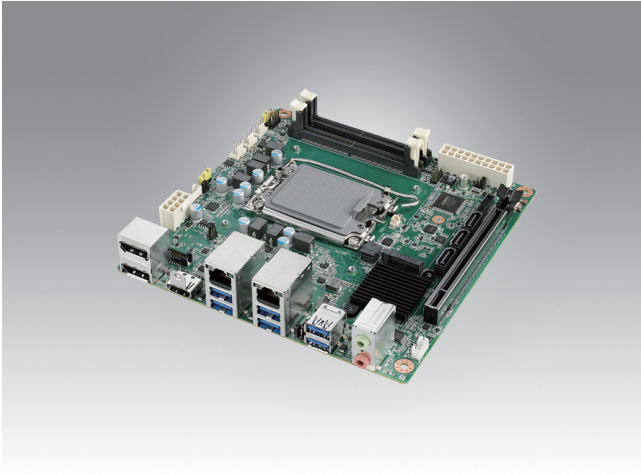

Features

- 12th/13th/14th Gen Intel® Core™ Desktop Processors, Up to 24Core, support Q670E/H610E chipset
- Dual channel DDR5 5600MHz, max. 96GB with two SODIMMs
- Super Speed I/O: PCIe x16 Gen5 (32GT/s), USB3.2 Gen2 (10Gbps), 2.5GbE
- Quad independent 4K displays with 2 DP, 1 HDMI, 1eDP
- Rich expansion: M.2 M key for NVMe SSD, M.2 E key for wireless, 3 SATA(RAID 0,1,5)
- TPM2.0 support
- SUSI API, WISE-DeviceOn and Embedded Software



Specifications

	CPU	i9-14900	i9-14900T	i7-14700	i7-14700T	i5-14500	i5-14500T	i5-14400	i5-14400T	i3-14100	i3-14100T		
14th Generation Processors	CPU	i9-14900	i9-14900T	i7-14700	i7-14700T	i5-14500	i5-14500T	i5-14400	i5-14400T	i3-14100	i3-14100T		
	Core Number	24	24	20	20	14	14	10	10	8	8		
	Base frequency (GHz)	2.0/1.5	1.1/0.8	2.1/1.5	1.3/0.9	2.6/1.9	1.7/1.2	2.5/1.8	1.5/1.1	3.5/NA	2.7/NA		
	Max Speed (GHz)	5.8/4.3	5.5/4.0	5.4/4.2	5.2/3.7	5.0/3.7	4.8/3.4	4.7/3.5	4.5/3.2	4.7/NA	4.4/NA		
	Smart cache (MB)	36MB	36MB	33MB	33MB	24MB	24MB	20MB	20MB	12MB	12MB		
	TDP (W)	65W	35W	65W	35W	65W	35W	65W	35W	65W	35W		
13th Generation Processors	CPU	i9-13900E / i9-13900	i9-13900TE	i7-13700E / i7-13700	i7-13700TE	i5-13500E / i5-13500	i5-13500TE	i5-13400E / i5-13400	i3-13100E / i3-13100	i3-13100TE			
	Core Number	24	24	16	16	14	14	10	4	4			
	Base frequency (GHz)	1.8/2.0	1	1.9/2.1	0.8	2.4/2.6	1.3	2.4/2.5	3.3/3.4	2.4			
	Max Speed (GHz)	5.2/5.6	5	5.1/5.2	4.8	4.6/4.8	4.5	4.6	4.4/4.5	4.1			
	Smart cache (MB)	36	36	30	30	24	24	20	12	12			
	TDP (W)	65	35	65	35	65	35	65	60	35			
12th Generation Processors	CPU	i9-12900E / i9-12900	i9-12900TE	i7-12700E / i7-12700	i7-12700TE	i5-12500E / i5-12500/12400	i5-12500TE	i3-12100E / i3-12100	i3-12100TE	G7400E	G7400TE	G6900E	G6900TE
	Core Number	16	16	12	12	6	6	4	4	2	2	2	2
	Base frequency (GHz)	2.3/2.4	1.1	2.1	1.4	2.9/3.0/2.5	1.9	3.2	2.1	3.6	3	3	2.4
	Max Speed (GHz)	5	4.8	4.8	4.7	4.5/4.6/4.4	4.3	4.2/4.3	4	NA	NA	NA	NA
	Smart cache (MB)	30	30	25	25	18	18	12	12	6	6	4	4
	TDP (W)	65	35	65	35	65	35	60	35	46	35	46	35
Processor System	Chipset	Q670E / H610E											
	BIOS	AMI EFI 256Mb SPI											
Expansion Slot	M.2	1 M-Key for SSD, 1 E-Key for Wireless connection											
	PCIe x16	PCIe x16 Gen5(32GT/s) for discrete GPU card and storage devices											
Memory	Technology	Dual Channel DDR5, up to 5600 MHz (non-ECC)											
	Max. Capacity	96GB (up to 48GB per SODIMM)											
	Socket	2 x 262pin SODIMM											
Graphics	Controller	up to Intel® UHD Graphics 770											
	HDMI	HDMI2.0b, supports max. resolution 4096 x 2160 @ 60 Hz											
	DP	DP1.4a, supports max. resolution 4096 x 2304 @ 60 Hz											
	eDP	By Default, with internal pin header, supports max. resolution 4096 x 2304 @ 60 Hz											
	LVDS	By Option, internal pin header, supports single/dual channel 18/24-bit with maximum resolution up to 1920 x 1200 @ 60 Hz (eDP coloy with LVDS)											
	Multi Displays	up to 4 independent displays (combination of 2DP, 1HDMI, 1eDP)											
Network	ETHERNET	up to 2500 Mb/s											
	Controller	Intel I219LM and Intel i226											
	Connector	2 x RJ45											
SATA	Max data transfer rate	600 MB/s											
	Channel	3 x SATAIII											
Rear I/O	DP	2											
	HDMI	1											
	Ethernet	2											
	USB	Up to 6 USB3.2 (Q670E: 6 USB3.2 Gen2; H610E: 2 USB3.2 Gen1 (optional 2 USB3.2 Gen1) & 2 USB2.0)											
	Audio	1 (default with Line out/Mic in) (Line in option)											
Internal Connector	USB	2 USB2.0											
	eDP/LVDS	1 eDP (LVDS coloy with eDP)											
	Serial	2 (COM1 RS-232, COM2 RS232/422/485)											
	SATA	3											
	M.2	1 M-key (dimension: 2280) 1 E-key (dimension: 2230)											
	GPIO	6-bit											
Watchdog Timer	Output	System reset											
	Interval	Programmable 1 ~ 255 sec/min											
Power Requirements	Boost	92.7W											
	Typical	68.9W											
Environment	Temperature	Operating: 0 ~ 60° C (32 ~ 140° F), depends on CPU speed and cooler solution											
	Storage	Non-Operating: -40 ~ 85° C (-40 ~ 185° F)											
Physical Characteristics	Dimensions	170 mm x 170 mm (6.69" x 6.69")											

Block Diagram

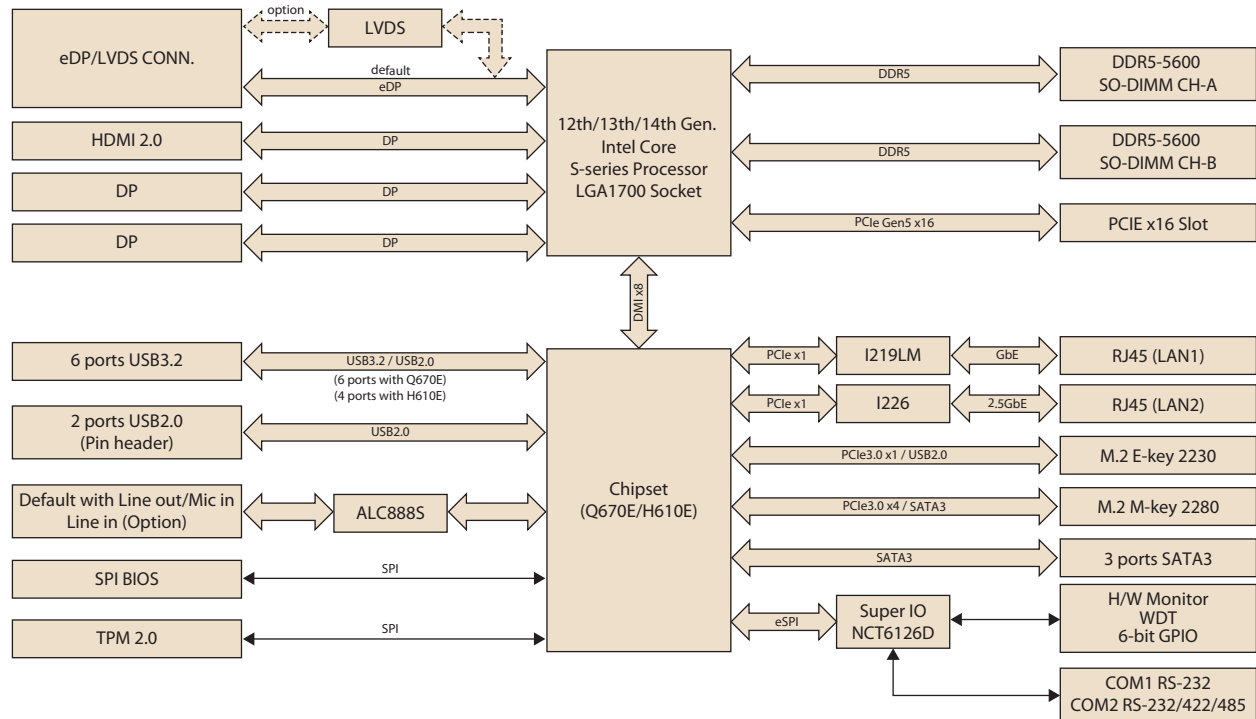

Ordering Information

P/N	Chipset	HDMI	LVDS/eDP	DP	GbE	2.5GbE	COM	SATAIII	USB3.2	USB2.0	M.2 M key	M.2 E key	PCIex16	TPM	AMP
AIMB-278Q-EAB1	Q670E	1	(1)/1	2	1	1	2	3	6	2	1	1	1	1	1
AIMB-278Q-LAB1	Q670E	1	1/(1)	2	1	1	2	3	6	2	1	1	1	1	1
AIMB-278H-EAB1	H610E	(1)	(1)/1	2	1	(1)	2	2	2/(2)	4	1	1	1	(1)	(1)

*() Supports by BOM options

Packing List

Part Number	Description	Quantity
1700003194	SATA HDD cable	1
1700031130-01	1-to-2 serial port cable, 20cm	1
1960109548T001	I/O port bracket	1
2046027800	Startup manual for AIMB-278	1

Optional Accessory

Part Number	Description
1700029719-01	M cable USB-A 9P(F)x2/2x10P-2.0 30CM USB3.0
1970005349T001	LGA1700 CPU Cooler H: 55.4mm (for TDP 65W)
1970005672T001	LGA1700 CPU Cooler H: 32mm (for TDP 35W)

I/O View



Embedded OS/API

OS/API	Part No.	968 P/N	Description
Windows 10	20706WX1ES0015	968QW21ELE	img W10 21EL AIMB-278 64b 21H2 ENU
Windows 10	20706WX1HS0015	968QW21HLE	img W10 21HL AIMB-278 64b 21H2 ENU
Windows 10	20706WX1VS0015	968QW21VLE	img W10 21VL AIMB-278 64b 21H2 ENU
Ubuntu22.04	20706U22DS0017	968MOU204D	img Ubuntu AIMB-278 64b 22.04 ENU

Optional Chassis

Part Number	Description
EPC-B2000-A030	Mini-ITX Chassis with 350W ATX power supply

Our company network supports you worldwide with offices in Germany, Austria, Switzerland, the UK and the USA.
For more information please contact:

Headquarters

Germany



FORTEC
GROUP

FORTEC Elektronik AG
Augsburger Str. 2b
82110 Germering

Phone: +49 89 894450-0
E-Mail: info@fortecag.de
Internet: www.fortecag.de

Fortec Group Members

Austria



FORTEC
INTEGRATED

FORTEC Integrated GmbH Office Vienna
Nuschinggasse 12
1230 Wien

Phone: +43 1 8673492-0
E-Mail: info@fortec-integrated.de
Internet: www.fortec-integrated.de

Germany



FORTEC
INTEGRATED

FORTEC Integrated GmbH
Augsburger Str. 2b
82110 Germering

Phone: +49 89 894363-0
E-Mail: info@fortec-integrated.de
Internet: www.fortec-integrated.de

Switzerland



FORTEC
SWITZERLAND

FORTEC Switzerland AG
Bahnhofstraße 3
5436 Würenlos

Phone: +41 44 7446111
E-Mail: info@fortec.ch
Internet: www.fortec.ch

United Kingdom



FORTEC
UNITED KINGDOM

FORTEC Technology UK Ltd.
Osprey House, 1 Osprey Court
Hinchingbrooke Business Park
Huntingdon, Cambridgeshire, PE29 6FN

Phone: +44 1480 411600
E-Mail: info@fortec.uk
Internet: www.fortec.uk

USA



FORTEC
UNITED STATES

FORTEC US, Corp.
87 Raynor Avenue, Unit 1
Ronkonkoma, NY 11779

Phone: +1 631 5804360
E-Mail: info@fortec.us
Internet: www.fortec.us