



OUR GLOBAL
COMPETENCE
CENTRES

 APOLLO DISPLAY
TECHNOLOGIES



FORTEC
INTEGRATED



FORTEC
UNITED KINGDOM



Manual

congatec

conga-PA7

2.5" Pico-ITX™ single board computer with Intel® Elkhart Lake processor Atom™ x6000E, Pentium® and Celeron®

J series

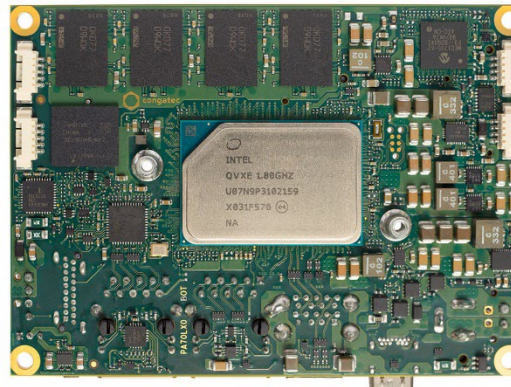

The information contained in this document has been carefully researched and is, to the best of our knowledge, accurate. However, we assume no liability for any product failures or damages, immediate or consequential, resulting from the use of the information provided herein. Our products are not intended for use in systems in which failures of product could result in personal injury. All trademarks mentioned herein are property of their respective owners. All specifications are subject to change without notice.

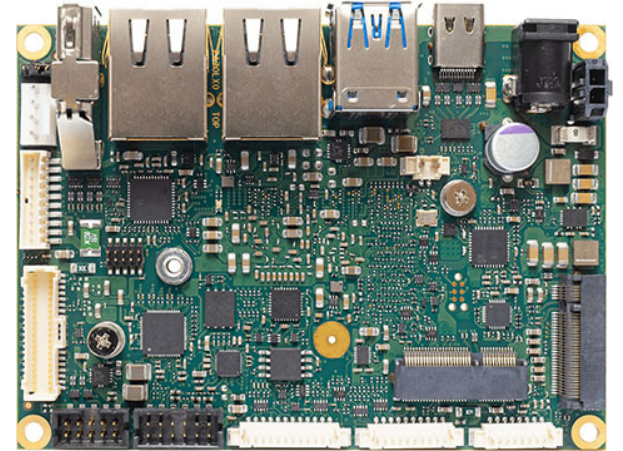

conga-PA7

Pico-ITX SBC with Intel® Atom® x6000E/RE, Intel® Pentium® and Celeron® J Series Processors

User's Guide

Revision 1.03

Revision History

| Revision | Date (yyyy-mm-dd) | Author | Changes |
|----------|-------------------|--------|---|
| 0.1 | 2021-04-15 | BEU | <ul style="list-style-type: none">• Preliminary release |
| 0.2 | 2021-07-02 | BEU | <ul style="list-style-type: none">• Added Software License Information• Updated section 6.6 "congatec Battery Management Interface" |
| 1.00 | 2021-12-18 | BEU | <ul style="list-style-type: none">• Updated processor from J6425 to J6426 for PN 048920 in Table 1 "conga-PA7 Commercial Variants"• Removed Table 5 "Power Supplies" and removed reference to this table from note in section 5.1.1 "DC Power Jack"• Updated Table 5 "Feature Summary"• Added note to section 2.2 "Supported Operating Systems" and updated section 6.5.4 "OEM BIOS Code/Data" because CSM is no longer supported• Removed support for Windows IoT 10 Core from section 2.1 "Feature List" and 2.2 "Supported Operating Systems"• Added values to Table 7 " Power Consumption Values" and Table 8 " CMOS Battery Power Consumption"• Updated block diagram in section 3 "Block Diagram"• Updated all drawings in section 4 "Cooling Solutions"• Changed picture of connector X8 in section 5.5.3 "USB 2.0 Header"• Added note about supported OS for the CAN ports in section 5.9 "CAN Ports"• Removed specific naming of microcontroller in section 6.4 "congatec Board Controller (cBC)"• Removed SMBus from section 6.6 "congatec Battery Management Interface" |
| 1.01 | 2023-08-16 | BEU | <ul style="list-style-type: none">• Updated title page• Updated RoHS Directive in preface section• Updated terminology in preface section• Added CPU use conditions, Tjunction, and DTR information to Table 2 and 3• Added note about a Windows 10 issue with S3 to section 2.2 "Supported Operating Systems"• Updated section 6.4.2 "Power Loss Control"• Added section 6.4.4 " Enhanced Soft-Off State" |
| 1.02 | 2023-12-13 | BEU | <ul style="list-style-type: none">• Added note to section 2.7 "Environmental Specifications"• Added caution and note to section 4 "Cooling Solutions" |
| 1.03 | 2024-01-04 | BEU | <ul style="list-style-type: none">• Updated audio codec in sections 2.1 "Feature List" and 5.4 "Audio Header" |

Preface

This user's guide provides information about the components, features and connectors available on the conga-PA7 Pico-ITX SBC.

Software Licenses

Notice Regarding Open Source Software

The congatec products contain Open Source software that has been released by programmers under specific licensing requirements such as the "General Public License" (GPL) Version 2 or 3, the "Lesser General Public License" (LGPL), the "ApacheLicense" or similar licenses.

You can find the specific details at <https://www.congatec.com/en/licenses/>. Search for the revision of the BIOS/UEFI or Board Controller Software (as shown in the POST screen or BIOS setup) to get the complete product related license information. To the extent that any accompanying material such as instruction manuals, handbooks etc. contain copyright notices, conditions of use or licensing requirements that contradict any applicable Open Source license, these conditions are inapplicable.

The use and distribution of any Open Source software contained in the product is exclusively governed by the respective Open Source license. The Open Source software is provided by its programmers without ANY WARRANTY, whether implied or expressed, of any fitness for a particular purpose, and the programmers DECLINE ALL LIABILITY for damages, direct or indirect, that result from the use of this software.

OEM/ CGUTL BIOS

BIOS/UEFI modified by customer via the congatec System Utility (CGUTL) is subject to the same license as the BIOS/UEFI it is based on. You can find the specific details at <https://www.congatec.com/en/licenses/>.

Disclaimer

The information contained within this user's guide, including but not limited to any product specification, is subject to change without notice.

congatec GmbH provides no warranty with regard to this user's guide or any other information contained herein and hereby expressly disclaims any implied warranties of merchantability or fitness for any particular purpose with regard to any of the foregoing. congatec GmbH assumes no liability for any damages incurred directly or indirectly from any technical or typographical errors or omissions contained herein or for discrepancies between the product and the user's guide. In no event shall congatec GmbH be liable for any incidental, consequential, special, or exemplary damages, whether based on tort, contract or otherwise, arising out of or in connection with this user's guide or any other information contained herein or the use thereof.

Intended Audience

This user's guide is intended for technically qualified personnel. It is not intended for general audiences.

RoHS Directive

All congatec GmbH designs comply with EU RoHS Directive 2011/65/EU and Delegated Directive 2015/863.

Electrostatic Sensitive Device



All congatec GmbH products are electrostatic sensitive devices. They are enclosed in static shielding bags, and shipped enclosed in secondary packaging (protective packaging). The secondary packaging does not provide electrostatic protection.

Do not remove the device from the static shielding bag or handle it, except at an electrostatic-free workstation. Also, do not ship or store electronic devices near strong electrostatic, electromagnetic, magnetic, or radioactive fields unless the device is contained within its original packaging. Be aware that failure to comply with these guidelines will void the congatec GmbH Limited Warranty.

Symbols

The following symbols are used in this user's guide:



Warning

Warnings indicate conditions that, if not observed, can cause personal injury.



Caution

Cautions warn the user about how to prevent damage to hardware or loss of data.



Note

Notes call attention to important information that should be observed.



Connector Type

Describes the connector used on the Single Board Computer and a possible mating connector.

Copyright Notice

Copyright © 2021, congatec GmbH. All rights reserved. All text, pictures and graphics are protected by copyrights. No copying is permitted without written permission from congatec GmbH.

congatec GmbH has made every attempt to ensure that the information in this document is accurate yet the information contained within is supplied "as-is".

Trademarks

Product names, logos, brands, and other trademarks featured or referred to within this user's guide, or the congatec website, are the property of their respective trademark holders. These trademark holders are not affiliated with congatec GmbH, our products, or our website.

Warranty

congatec GmbH makes no representation, warranty or guaranty, express or implied regarding the products except its standard form of limited warranty ("Limited Warranty") per the terms and conditions of the congatec entity, which the product is delivered from. These terms and conditions can be downloaded from www.congatec.com. congatec GmbH may in its sole discretion modify its Limited Warranty at any time and from time to time.

The products may include software. Use of the software is subject to the terms and conditions set out in the respective owner's license agreements, which are available at www.congatec.com and/or upon request.

Beginning on the date of shipment to its direct customer and continuing for the published warranty period, congatec GmbH represents that the products are new and warrants that each product failing to function properly under normal use, due to a defect in materials or workmanship or due to non conformance to the agreed upon specifications, will be repaired or exchanged, at congatec's option and expense.

Customer will obtain a Return Material Authorization ("RMA") number from congatec GmbH prior to returning the non conforming product freight prepaid. congatec GmbH will pay for transporting the repaired or exchanged product to the customer.

Repaired, replaced or exchanged product will be warranted for the repair warranty period in effect as of the date the repaired, exchanged or replaced product is shipped by congatec, or the remainder of the original warranty, whichever is longer. This Limited Warranty extends to congatec's direct customer only and is not assignable or transferable.

Except as set forth in writing in the Limited Warranty, congatec makes no performance representations, warranties, or guarantees, either express or implied, oral or written, with respect to the products, including without limitation any implied warranty (a) of merchantability, (b) of fitness for a particular purpose, or (c) arising from course of performance, course of dealing, or usage of trade.

congatec GmbH shall in no event be liable to the end user for collateral or consequential damages of any kind. congatec shall not otherwise be liable for loss, damage or expense directly or indirectly arising from the use of the product or from any other cause. The sole and exclusive remedy against congatec, whether a claim sound in contract, warranty, tort or any other legal theory, shall be repair or replacement of the product only.

Certification

congatec GmbH is certified to DIN EN ISO 9001 standard.



Technical Support

congatec GmbH technicians and engineers are committed to providing the best possible technical support for our customers so that our products can be easily used and implemented. We request that you first visit our website at www.congatec.com for the latest documentation, utilities and drivers, which have been made available to assist you. If you still require assistance after visiting our website then contact our technical support department by email at support@congatec.com

Terminology

| Term | Description |
|----------------------|---|
| cBC | congatec Board Controller |
| DDC | Display Data Channel is an I ² C bus interface between a display and a graphics adapter. |
| DTR | Dynamic Temperature Range |
| GbE | Gigabit Ethernet |
| HDA | High Definition Audio |
| I ² C Bus | Inter-Integrated Circuit Bus |
| LPC | Low Pin-Count |
| LVDS | Low-Voltage Differential Signaling |
| N.A | Not available |
| N.C | Not connected |
| PCIe | Peripheral Component Interface Express |
| S/PDIF | Sony/Philips Digital Interconnect Format |
| SATA | Serial AT Attachment: serial-interface standard for hard disks |
| SBC | Single Board Computer |
| SDIO | Secure Digital Input Output |
| SPI | Serial Peripheral Interface |
| TBD | To be determined |
| TMDS | Transition Minimized Differential Signaling |
| USB | Universal Serial Bus |

Contents

| | | | | | |
|-------|------------------------------------|----|---------|---|----|
| 1 | Introduction | 10 | 5.7.1 | DP++ Port..... | 30 |
| 1.1 | Pico-ITX Concept..... | 10 | 5.7.2 | USB Type-C® Port..... | 30 |
| 1.2 | conga-PA7..... | 10 | 5.7.3 | LVDS Header..... | 31 |
| 1.2.1 | Options Information..... | 11 | 5.7.3.1 | Backlight Power Header | 32 |
| 1.2.2 | Optional Accessories | 13 | 5.7.3.2 | Panel Power Jumper | 32 |
| 2 | Specification | 14 | 5.8 | COM Ports | 33 |
| 2.1 | Feature List | 14 | 5.9 | CAN Ports | 34 |
| 2.2 | Supported Operating Systems | 15 | 5.10 | M.2 Key-B | 35 |
| 2.3 | Mechanical Dimensions | 15 | 5.11 | M.2 Key-E | 36 |
| 2.4 | Power Supply Voltage..... | 15 | 5.12 | CPU Fan Header | 38 |
| 2.5 | Power Consumption | 16 | 5.13 | BIOS Flash Header..... | 38 |
| 2.6 | Supply Voltage Battery Power | 17 | 6 | Additional Features..... | 39 |
| 2.7 | Environmental Specifications..... | 18 | 6.1 | Feature Connectors | 39 |
| 3 | Block Diagram..... | 19 | 6.1.1 | Buttons and LEDs | 39 |
| 4 | Cooling Solutions..... | 20 | 6.1.2 | I2C and Watchdog..... | 40 |
| 4.1 | CSP Dimensions | 21 | 6.1.3 | GPIOs and Real-Time Trigger Signals..... | 41 |
| 4.2 | HSP Dimensions..... | 23 | 6.2 | DRAM..... | 41 |
| 5 | Connector Description..... | 25 | 6.3 | Flash Storage | 41 |
| 5.1 | Power Supply Connectors..... | 25 | 6.4 | congatec Board Controller (cBC)..... | 42 |
| 5.1.1 | DC Power Jack..... | 25 | 6.4.1 | Fan Control | 42 |
| 5.1.2 | 2-Pin Power Connector | 25 | 6.4.2 | Power Loss Control | 42 |
| 5.1.3 | USB Type-C® Port..... | 26 | 6.4.3 | Board Information | 42 |
| 5.2 | Cell Battery Header | 26 | 6.4.4 | Enhanced Soft-Off State | 42 |
| 5.3 | System State LED..... | 27 | 6.5 | OEM BIOS Customization..... | 43 |
| 5.4 | Audio Header | 27 | 6.5.1 | OEM Default Settings..... | 43 |
| 5.5 | USB Interfaces..... | 28 | 6.5.2 | OEM Boot Logo..... | 43 |
| 5.5.1 | USB Type-A Ports..... | 28 | 6.5.3 | OEM POST Logo | 43 |
| 5.5.2 | USB Type-C® Port..... | 28 | 6.5.4 | OEM BIOS Code/Data..... | 43 |
| 5.5.3 | USB 2.0 Header | 29 | 6.5.5 | OEM DXE Driver | 44 |
| 5.6 | Ethernet Ports | 29 | 6.6 | congatec Battery Management Interface | 44 |
| 5.7 | Display Interfaces..... | 30 | 6.7 | API Support (CGOS) | 44 |
| | | | 6.8 | Thermal/Voltage Monitoring..... | 44 |
| | | | 6.9 | External System Wake Event | 45 |
| | | | 6.10 | Security Features..... | 45 |

| | | |
|-----|--------------------------------------|----|
| 7 | Mechanical Drawing | 46 |
| 8 | BIOS Setup Description | 47 |
| 8.1 | Navigating the BIOS Setup Menu | 47 |
| 8.2 | BIOS Versions..... | 47 |
| 8.3 | Updating the BIOS..... | 48 |
| 8.4 | Supported Flash Device..... | 48 |

List of Tables

| | | |
|----------|--------------------------------------|----|
| Table 1 | conga-PA7 Commercial Variants..... | 11 |
| Table 2 | conga-PA7 Industrial Variants | 12 |
| Table 3 | Cooling Solutions..... | 13 |
| Table 4 | Cables..... | 13 |
| Table 5 | Feature Summary..... | 14 |
| Table 6 | Measurement Description..... | 16 |
| Table 7 | Power Consumption Values..... | 17 |
| Table 8 | CMOS Battery Power Consumption | 17 |
| Table 9 | X21 Pinout | 25 |
| Table 10 | X22 Pinout | 25 |
| Table 11 | X23 Pinout | 26 |
| Table 12 | D20 Description..... | 27 |
| Table 13 | X6 Pinout | 27 |
| Table 14 | X8 Pinout | 29 |
| Table 15 | X12, X13 Description | 29 |
| Table 16 | X3 Pinout | 31 |
| Table 17 | X4 Pinout | 32 |
| Table 18 | X24 Settings..... | 32 |
| Table 19 | X15, X16 Pinout..... | 33 |
| Table 20 | X1, X2 Pinout..... | 34 |
| Table 21 | X10 Pinout | 35 |
| Table 22 | X11 Pinout | 36 |
| Table 23 | X17 Pinout | 38 |
| Table 24 | X14 Pinout | 38 |
| Table 25 | X18 Pinout | 39 |
| Table 26 | X19 Pinout | 40 |
| Table 27 | X20 Pinout | 41 |

1 Introduction

1.1 Pico-ITX Concept

The Pico-ITX form factor provides system designers and manufacturers with a standardized ultra compact platform for development. With a footprint of 100 mm x 72 mm, this scalable platform promotes the design of highly integrated, energy efficient systems. Due to its small size, the Pico-ITX form factor enables PC appliance designers not only to design attractive low cost devices but also allows them to explore a huge variety of product development options - from compact space-saving designs to fully functional Information Station and Value PC systems. This helps to reduce product design cycle and encourages rapid innovation in system design to meet the ever-changing needs of the market.

Additionally, the boards can be passively cooled, presenting opportunities for fanless designs. The Pico-ITX boards are equipped with various interfaces such as PCI Express, USB, Ethernet, Displays and Audio.

1.2 conga-PA7

The conga-PA7 is a Single Board Computer (SBC) design based on the Pico-ITX specification. The conga-PA7 SBC features the Intel® Atom® x6000E/RE Series and Intel® Pentium® and Celeron® J Series processors (formerly Elkhart Lake). With maximum 12 W TDP processors, the SBC offers Ultra Low Power boards with high computing performance and outstanding graphics. Additionally, the SBC offers onboard LPDDR4x memory, eMMC storage, multiple I/O interfaces, up to three independent display interfaces, and various congatec embedded features.

With small board size and low height keep-out zones, the conga-PA7 provides manufacturers and system designers with the opportunity to design compact systems for space restricted areas.

The various features and capabilities offered by the conga-PA7 makes it ideal for the design of compact, energy efficient, performance-oriented embedded systems.

1.2.1 Options Information

The conga-PA7 is currently available in eight variants. This user's guide describes all of these variants. The tables below show the different configurations available. Check for the PN that applies to your product. This will tell you what options described in this user's guide are available on your particular module.

Table 1 conga-PA7 Commercial Variants

| PN | | 048900 | 048901 | 048902 | 048920 | 048921 |
|---|------|-----------------------------------|-----------------------------------|-----------------------------------|-------------------------------------|-------------------------------------|
| Intel® Processor | | Atom® x6425E Quad Core 2.0 GHz | Atom® x6413E Quad Core 1.5 GHz | Atom® x6211E Dual Core 1.3 GHz | Pentium® J6426 Quad Core 2.0 GHz | Celeron® J6413 Quad Core 1.8 GHz |
| Burst Frequency | | 2.7 GHz | 2.7 GHz | 3.0 GHz | 2.7 GHz * | 2.7 GHz |
| Onboard Memory | | 8 GB 3733 MT/s | 4 GB 3200 MT/s | 4 GB 3200 MT/s | 8 GB 3733 MT/s | 4 GB 3733 MT/s |
| eMMC | | 64 GB | 32 GB | 32 GB | 64 GB | 32 GB |
| Processor Graphics | | Intel® UHD Graphics | Intel® UHD Graphics | Intel® UHD Graphics | Intel® UHD Graphics | Intel® UHD Graphics |
| Execution Units | | 32 | 16 | 16 | 32 | 16 |
| Graphics Base / Burst | | 500 MHz / 750 MHz | 500 MHz / 750 MHz | 350 MHz / 750 MHz | 400 MHz / 850 MHz | 400 MHz / 800 MHz |
| Processor TDP (Max) | | 12 W | 9 W | 6 W | 10 W | 10 W |
| CPU Use Condition ¹ | | Embedded | Embedded | Embedded | PC Client | PC Client |
| CPU Tjunction | Min. | -40°C | -40°C | -40°C | 0°C | 0°C |
| | Max. | 105°C | 105°C | 105°C | 105°C | 105°C |
| DTR (Cold to Hot Transition) ² | | T _{Boot} + 90°C | T _{Boot} + 90°C | T _{Boot} + 90°C | T _{Boot} + 70°C | T _{Boot} + 70°C |
| DTR (Hot to Cold Transition) ² | | T _{Boot} - 90°C | T _{Boot} - 90°C | T _{Boot} - 90°C | T _{Boot} - 70°C | T _{Boot} - 70°C |

* Up to 3.0 GHz if only one or two cores are active.

Table 2 conga-PA7 Industrial Variants

| PN | 048910 | 048911 | 048912 |
|--|------------------------------------|------------------------------------|------------------------------------|
| Intel® Processor | Atom® x6425RE Quad Core 1.9 GHz | Atom® x6414RE Quad Core 1.5 GHz | Atom® x6212RE Dual Core 1.2 GHz |
| Burst Frequency | N/A | N/A | N/A |
| Onboard Memory | 8 GB 4267 MT/s | 4 GB 3200 MT/s | 4 GB 3200 MT/s |
| eMMC | 64 GB | 32 GB | 32 GB |
| Processor Graphics | Intel® UHD Graphics | Intel® UHD Graphics | Intel® UHD Graphics |
| Execution Units | 32 | 16 | 16 |
| Graphics Base / Burst | 400 MHz / N/A | 400 MHz / N/A | 350 MHz / N/A |
| Processor TDP (Max) | 12 W | 9 W | 6 W |
| CPU Use Condition ¹ | Industrial | Industrial | Industrial |
| CPU | Min. | -40°C | -40°C |
| Tjunction | Max. | 110°C | 110°C |
| DTR (Cold to Hot Transition) _{2,3} | T _{Boot} + 90°C | T _{Boot} + 90°C | T _{Boot} + 90°C |
| | T _{Boot} + 110°C | T _{Boot} + 110°C | T _{Boot} + 110°C |
| DTR (Hot to Cold Transition) _{2,3} | T _{Boot} - 90°C | T _{Boot} - 90°C | T _{Boot} - 90°C |
| | T _{Boot} - 110°C | T _{Boot} - 110°C | T _{Boot} - 110°C |

 **Note**

- ¹ Intel SoC use conditions. For more information, see Intel documentation.
- ² T_{Boot} is the boot temperature. If the Tjunction is not within the DTR range, you must reboot the system. See Intel documentation for more information.
- ³ For DTR of ±110°C, the speed of any enabled USB 3.1 port must be limited to 5 Gb/s.

1.2.2 Optional Accessories

Table 3 Cooling Solutions

| Article | PN | Description |
|-------------------|--------|--|
| conga-PA7/HSP-T | 048950 | Heatspreader solution for conga-PA7 based on open silicon Intel Pentium and Celeron J and N processors. All standoffs are M2.5 thread. |
| conga-PA7/i-HSP-T | 048951 | Heatspreader solution for conga-PA7 based on lidded silicon Intel Atom x6000E processors. All standoffs are M2.5 thread. |
| conga-PA7/CSP-T | 048952 | Passive cooling solution for conga-PA7 based on open silicon Pentium and Celeron J and N processors. All standoffs are M2.5 thread. |
| conga-PA7/i-CSP-T | 048953 | Passive cooling solution for conga-PA7 based on lidded silicon Atom X6000E processors. All standoffs are M2.5 thread. |
| conga-PA7/HSP-B | 048954 | Heatspreader solution for conga-PA7 based on open silicon Intel Pentium and Celeron J and N processors. All standoffs are with 2.7mm borehole. |
| conga-PA7/i-HSP-B | 048955 | Heatspreader solution for conga-PA7 based on lidded silicon Intel Atom x6000E processors. All standoffs are with 2.7mm borehole. |

Table 4 Cables

| Article | PN | Description | Fits to Connector |
|----------------------------------|----------|---|-------------------|
| cab-Pico-ITX-Audio Cable Adapter | 14000146 | Audio cable adapter, 15cm | X6 |
| cab-Pico-ITX-Buttons-LED | 14000147 | Buttons and LEDs adapter, 15cm | X18 |
| cab-Pico-ITX-Buttons-LED, 100cm | 14000148 | Buttons and LEDs adapter, 100cm | X18 |
| cab-Pico-ITX-GPIO | 14000151 | GPIO cable, 15cm, wires with open ends | X20 |
| cab-Pico-ITX-RS232 | 14000152 | RS232 cable adapter, 15cm (Molex Picoblade to DSUB 9) | X15, X16 |
| cab-Pico-ITX-RS422 | 14000153 | RS422 cable adapter, embedded termination, 15cm (Molex Picoblade to DSUB 9) | X15, X16 |
| cab-Pico-ITX-RS485 | 14000154 | RS485 cable adapter, embedded termination, 15cm (Molex Picoblade to DSUB 9) | X15, X16 |
| cab-Pico-ITX-External-Power | 14000157 | Power cable with DC jack and 4mm banana plugs, 100cm | X21 |
| cab-Pico-ITX-Feature | 14000161 | Feature cable, 15cm, wires with open ends | X19 |
| cab-Pico-ITX-Power | 14000172 | Power cable adapter from DC jack to Molex MicroFit (int. power connector) | X22 |
| cab-Pico-ITX-Backlight | 14000206 | LCD backlight cable for AUO G170EG01 V1 | X4 |
| cab-Pico-ITX-USB20-Twin | 14000210 | USB 2.0 cable adapter, 2mm pin header, 20 / 25 cm | X8 |
| cab-Pico-ITX-LVDS | 14000211 | LCD data cable for AUO G170EG01 V1 (LVDS) | X3 |

2 Specification

2.1 Feature List

Table 5 Feature Summary

| | | | |
|----------------------------------|---|--|--|
| Form Factor | Pico-ITX Single Board Computer; 100 x 72 mm | | |
| CPU | Intel® Atom® x6000E/RE Series and Intel® Pentium® and Celeron® J Series processors (formerly Elkhart Lake) | | |
| DRAM | up to 4 Channels onboard LPDDR4x with up to 4,267 MT/s; max. system capacity 16 GB | | |
| Chipset | Integrated in SoC | | |
| Ethernet | 2x LAN Gbit / 100 Mbit / 10 Mbit with TSN support and Out-Of-Band Management 2x real-time trigger | | |
| Mass Storage | eMMC 5.1 onboard flash up to 64 GB (optional up to 128 GB) | | |
| Sound | Intel® High Definition Audio via codec TSI 92HD91B | | |
| Graphics | Intel® UHD Graphics for 10th Gen Intel® Processor | | |
| Internal Connectors | 2x USB 2.0 1x LVDS 18/24bit 1x Backlight power connector (5V, 12V) 1x Audio Connector (HP/Line Out, MIC In, S/PDIF Out) 1x Power In (+12V) 2x COM (RS232/422/485) | | 1x Fan Connector with PWM 3x Feature Connector 1x M.2 key ID B type 2280 (2 PCIe lanes/SATA, USB 2.0) or type 2242 (opt.) 1x M.2 key ID E type 2230 (1 PCIe lane, USB 2.0) 2x CAN (opt.) 1x 2-pin Header for RTC Power Backup |
| External Connectors | 1x DP++ 2x LAN RJ45 1x USB 3.1 Gen2 Type C (with Power Delivery and DP Alt Mode) | | 2x USB 3.1 Gen2 Type A 1x DC-In |
| congatec Board controller | Multistage watchdog; non-volatile user data storage; manufacturing and board Information; board statistics; fast mode and multi-master I ² C bus; power loss control | | |
| Embedded BIOS Feature | AMI Aptio® UEFI firmware; 32 Mbyte serial SPI with congatec Embedded BIOS features; OEM Logo; OEM CMOS Defaults; LCD Control; Display Auto Detection; Backlight Control; Flash Update | | |
| Security | TPM 2.0 | | |
| Power Management | ACPI 5.0 compliant; Smart Battery Management | | |
| Operating Systems | Microsoft® Windows 10; Microsoft® Windows 10 IoT Enterprise; Linux; Android; RTS Hypervisor | | |
| Temperature Range | Commercial: Operating Temperature: 0 to +60°C Industrial: Operating Temperature: -40 to +85°C | | Storage Temperature: -20 to +70°C Storage Temperature: -40 to +85°C |
| Humidity | Operating: 10 to 90% r. H. non cond. Storage: 5 to 95% r. H. non cond. | | |
| Size | 100 x 72 mm | | |

2.2 Supported Operating Systems

The conga-PA7 supports the following operating systems:

- Microsoft® Windows 10
- Microsoft® Windows 10 IoT Enterprise
- Linux® (Yocto, Ubuntu, Wind River)
- Android®
- RTS Hypervisor



Note

4. *The conga-PA7 only supports native UEFI operating systems. Legacy operating systems that require the Compatibility Support Module (CSM) as part of the UEFI firmware are not supported.*
5. *Windows® 10 version 21H2 (OS build 19044) may sporadically fail to wake from S3 sleep state (POST Code: 0300). congatec recommends updating to a later Windows® 10 version.*

2.3 Mechanical Dimensions

- 100 mm x 72 mm
- Top side max. 18.3 mm
- Bottom (CPU) side max. 3.4 mm

2.4 Power Supply Voltage

- 12 V DC \pm 10%



Caution

The maximum operating input voltage is 13.5 volts. Do not exceed this rating for a prolonged time. Otherwise, the system may be damaged or may have reliability issues.

2.5 Power Consumption

The power consumption values were measured with the following setup:

- conga-PA7
- conga-PA7 cooling solution
- Microsoft® Windows® 10



The CPU was stressed to its maximum workload with the Intel® Power Thermal Utility (PTU).

The power consumption values were recorded during the following system states:

Table 6 Measurement Description

| System State | Description | Comment |
|-------------------|--|---|
| S0: Minimum value | Lowest frequency mode (LFM) with minimum core voltage during desktop idle. | |
| S0: Maximum value | Highest frequency mode (HFM/Turbo Boost). | The CPU was stressed to its maximum frequency. |
| S0: Peak value | Highest power spike during the measurement of "S0: Maximum value". This state shows the peak value over a short period of time (worst case power consumption value). | Consider this value when designing the system's power supply to ensure that sufficient power is supplied during worst case scenarios. |
| S3 | Suspend to RAM state. | |
| S5 | Soft-Off state. | |
| S5e | Enhanced Soft-Off state. | |



1. *The fan was powered externally.*
2. *All other peripherals except the LCD monitor were disconnected before measurement.*

The tables below provide additional information about the power consumption data for each of the conga-PA7 variants offered. The values are recorded at various operating modes.

Table 7 Power Consumption Values

| PN | Memory Size | HW Rev. | BIOS Rev. | OS (64-bit) | CPU | | | Current (A) @ 12 V | | | | |
|--------|-------------|---------|-----------|-------------|----------------|-------|--------------------------|--------------------|---------|----------|------|------|
| | | | | | Variant | Cores | Base / Burst Freq. (GHz) | S0: Min | S0: Max | S0: Peak | S3 | S5 |
| 048900 | 8 GB | A.0 | PA70R010 | Windows® 10 | Atom® x6425E | 4 | 2.0 / 2.7 | 0.39 | 2.09 | 2.48 | 0.12 | 0.12 |
| 048901 | 4 GB | A.0 | PA70R010 | Windows® 10 | Atom® x6413E | 4 | 1.5 / 2.7 | 0.39 | 1.44 | 2.36 | 0.12 | 0.12 |
| 048902 | 4 GB | A.0 | PA70R010 | Windows® 10 | Atom® x6211E | 2 | 1.3 / 3.0 | 0.38 | 0.94 | 2.13 | 0.12 | 0.11 |
| 048910 | 8 GB | A.0 | PA70R010 | Windows® 10 | Atom® x6425RE | 4 | 1.9 / N/A | 0.37 | 1.29 | 1.40 | 0.12 | 0.12 |
| 048911 | 4 GB | A.0 | PA70R010 | Windows® 10 | Atom® x6414RE | 4 | 1.5 / N/A | 0.36 | 1.11 | 1.30 | 0.12 | 0.12 |
| 048912 | 4 GB | A.0 | PA70R010 | Windows® 10 | Atom® x6212RE | 2 | 1.2 / N/A | 0.37 | 0.88 | 1.10 | 0.12 | 0.12 |
| 048920 | 8 GB | A.0 | PA70R010 | Windows® 10 | Pentium® J6426 | 4 | 2.0 / 2.7* | 0.38 | 1.78 | 2.48 | 0.12 | 0.11 |
| 048921 | 4 GB | A.0 | PA70R010 | Windows® 10 | Celeron® J6413 | 4 | 1.8 / 2.7 | 0.42 | 1.68 | 2.43 | 0.14 | 0.14 |

* Up to 3.0 GHz if only one or two cores are active.



Note
With fast input voltage rise time, the inrush current may exceed the measured peak current.

2.6 Supply Voltage Battery Power

Table 8 CMOS Battery Power Consumption

| RTC @ | Voltage | Current |
|-------|---------|---------|
| -10°C | 3 V DC | 2.06 µA |
| 20°C | 3 V DC | 2.27 µA |
| 70°C | 3 V DC | 3.60 µA |



1. Do not use the CMOS battery power consumption values listed above to calculate CMOS battery lifetime.
2. Measure the CMOS battery power consumption in your customer specific application in worst case conditions (for example, during high temperature and high battery voltage).
3. Consider also the self-discharge of the battery when calculating the lifetime of the CMOS battery. For more information, refer to application note AN9_RTC_Battery_Lifetime.pdf on congatec GmbH website at www.congatec.com/support/application-notes.
4. We recommend to always have a CMOS battery present when operating the conga-PA7.

2.7 Environmental Specifications

| | | |
|-----------------------------------|-------------------------|------------------------|
| Temperature (commercial variants) | Operation: 0° to 60°C | Storage: -20° to +70°C |
| Temperature (industrial variants) | Operation: -40° to 85°C | Storage: -40° to +85°C |
| Humidity | Operation: 10% to 90% | Storage: 5% to 95% |



Caution

The above operating temperatures must be strictly adhered to at all times. Humidity specifications are for non-condensing conditions.



Note

For long term storage of the conga-PA7 (more than six months), keep the conga-PA7 in a climate-controlled building at a constant temperature between 5°C and 40°C, with humidity of less than 65% and at an altitude of less than 3000 m. Also ensure the storage location is dry and well ventilated. We do not recommend storing the conga-PA7 for more than five years under these conditions.

3 Block Diagram

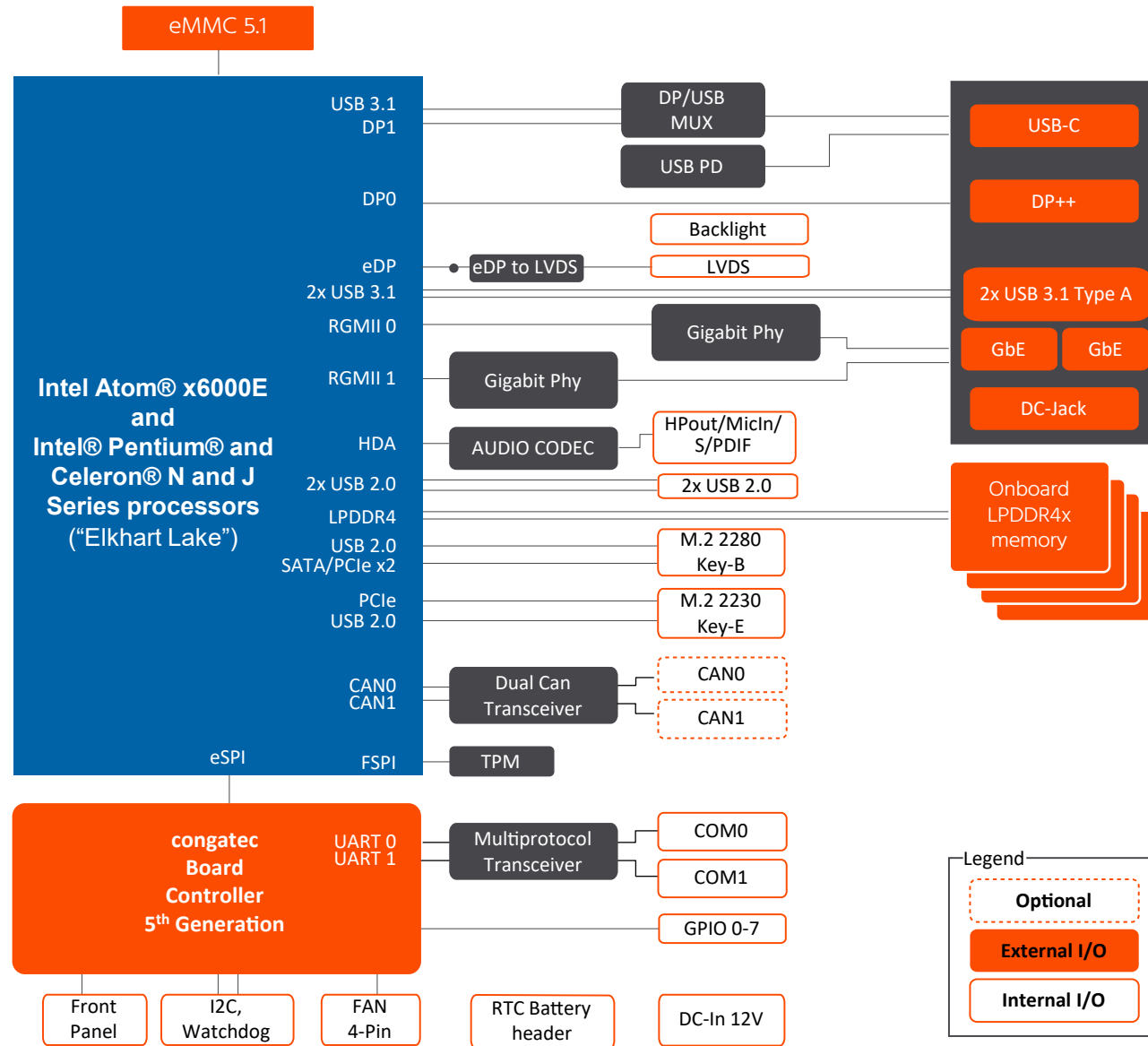

Note: * Assembly options on request only.

4 Cooling Solutions

congatec GmbH offers the cooling solutions listed in Table 3 for conga-PA7. The dimensions of the cooling solutions are shown in the sub-sections. All measurements are in millimeters.



Caution

1. *The congatec heatspreaders/cooling solutions are tested only within the commercial temperature range of 0° to 60°C. Therefore, if your application that features a congatec heatspreader/cooling solution operates outside this temperature range, ensure the correct operating temperature of the module is maintained at all times. This may require additional cooling components for your final application's thermal solution.*
2. *For adequate heat dissipation, use the mounting holes on the cooling solution to attach it to the module. Apply thread-locking fluid on the screws if the cooling solution is used in a high shock and/or vibration environment. To prevent the standoff from stripping or cross-threading, use non-threaded carrier board standoffs to mount threaded cooling solutions.*
3. *For applications that require vertically-mounted cooling solution, use only coolers that secure the thermal stacks with fixing post. Without the fixing post feature, the thermal stacks may move.*
4. *Do not exceed the recommended maximum torque. Doing so may damage the module or the carrier board, or both.*



Note

1. *We recommend a maximum torque of 0.3 Nm for the mounting screws.*
2. *The gap pad material used on congatec heatspreaders may contain silicon oil that can seep out over time depending on the environmental conditions it is subjected to. For more information about this subject, contact your local congatec sales representative and request the gap pad material manufacturer's specification.*
3. *For optimal thermal dissipation, do not store the congatec cooling solutions for more than six months.*

4.1 CSP Dimensions

PN: 048952

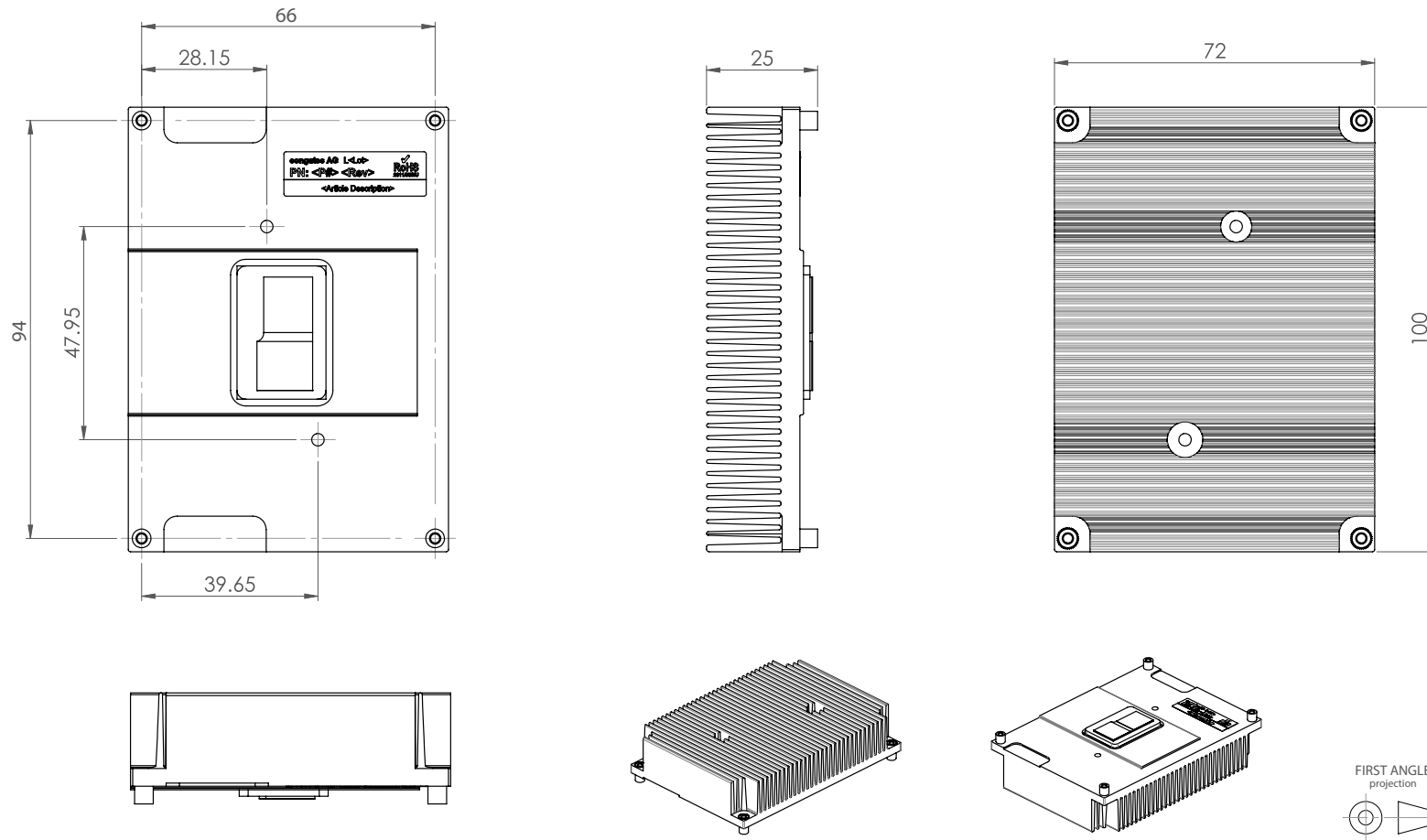

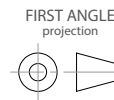
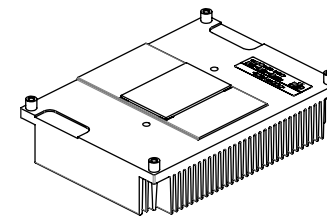
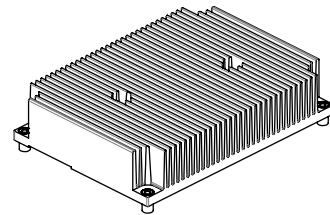
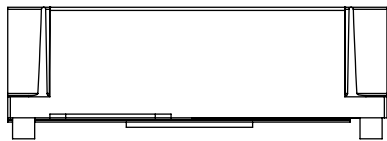
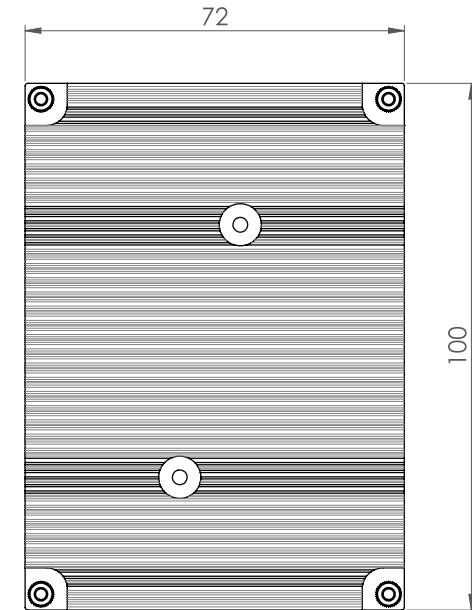
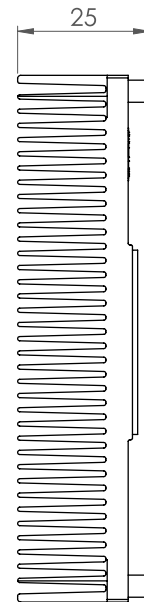
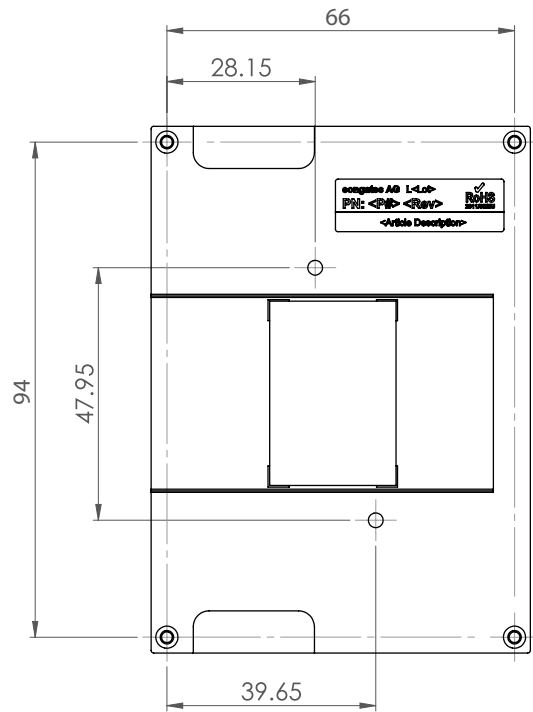

PN: 048953

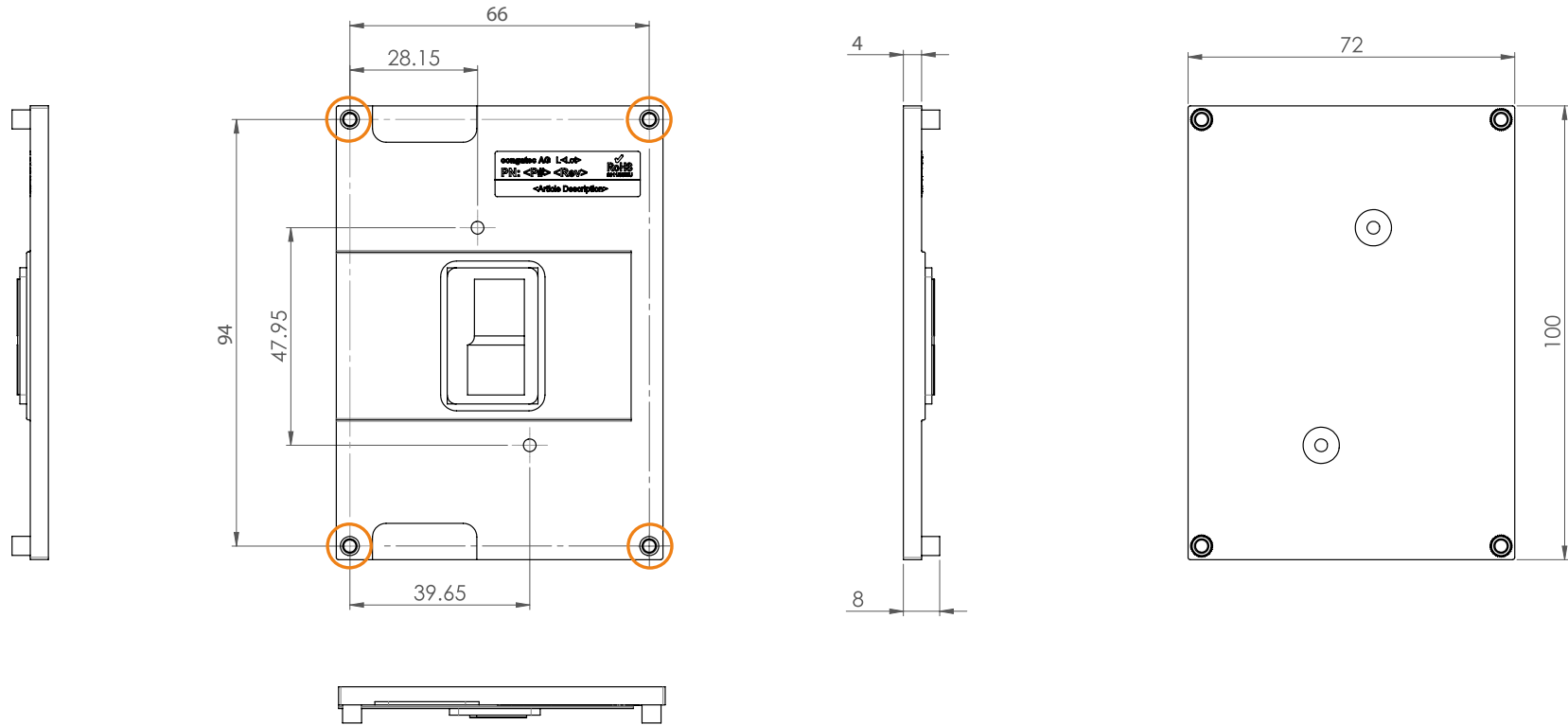

4.2 HSP Dimensions

PN: 048950, 048954



-  M2.5 x 8 mm threaded standoff (PN: 048950)
or
ø2.7 x 8 mm non-threaded standoff (PN: 048954)

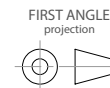
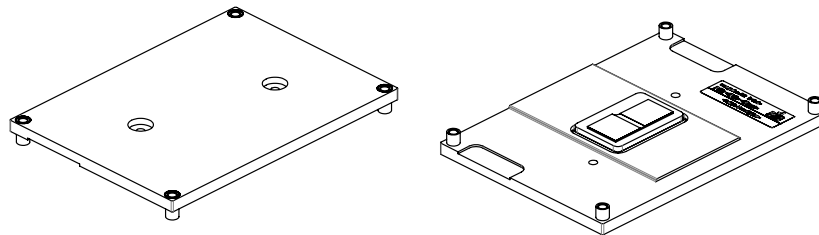

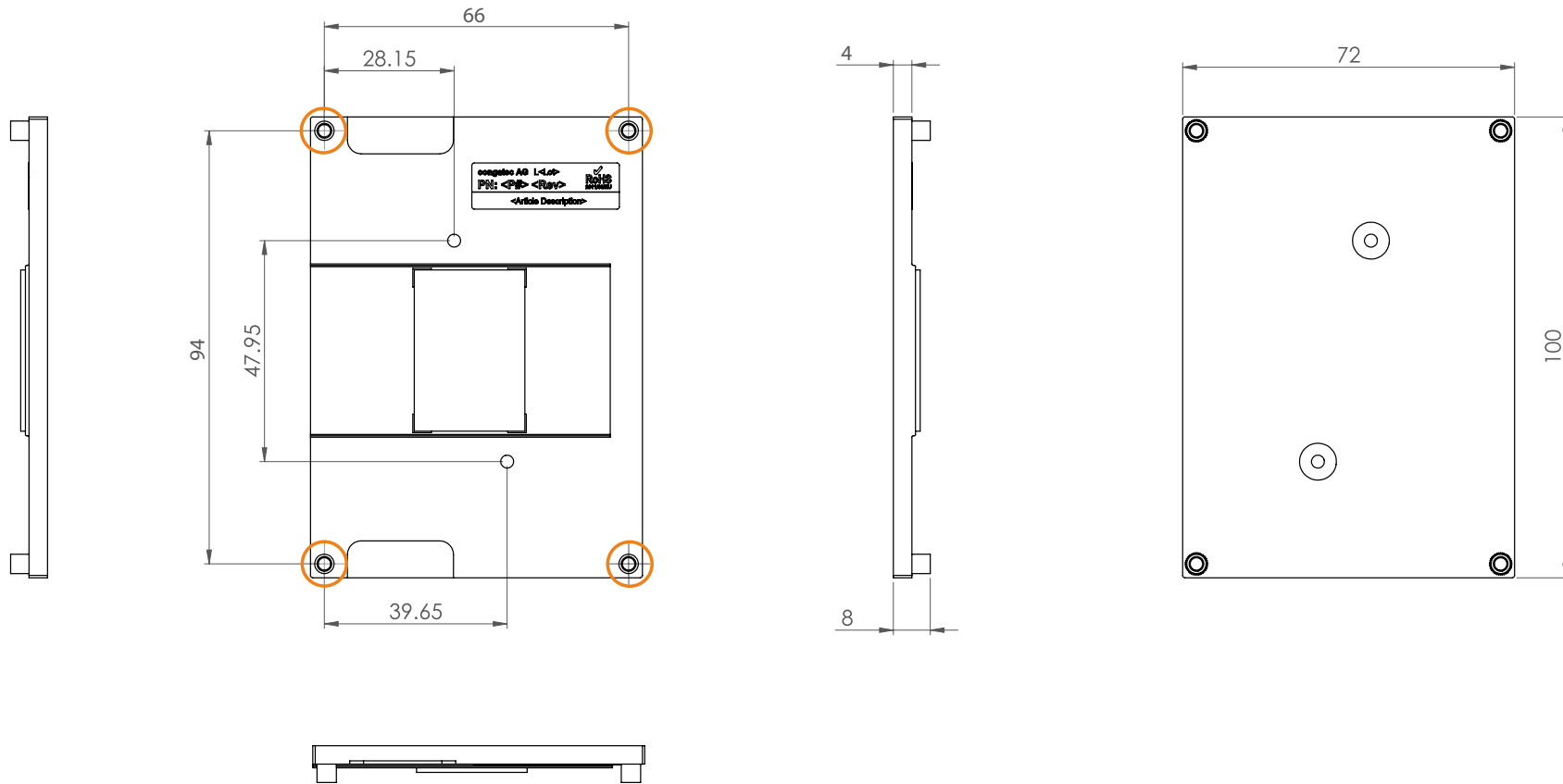

 M2.5 x 8 mm threaded standoff (PN: 048950)
 or
 ø2.7 x 8 mm non-threaded standoff (PN: 048954)

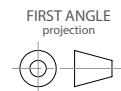
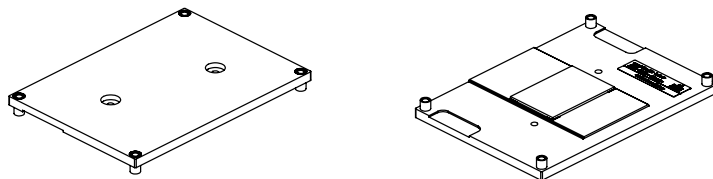

5 Connector Description

5.1 Power Supply Connectors

The conga-PA7 provides a DC power jack, a 2-pin power connector, and a USB Type-C® port to connect a power supply. Only connect one power supply to power the conga-PA7. The required power supply voltage is specified in section 2.4 "Power Supply Voltage".

5.1.1 DC Power Jack

The conga-PA7 provides a standard DC power jack (X21), protected against short transient overvoltage and ESD. Optionally, the conga-PA7 can provide a DC power jack with locking mechanism, including screw type connectors (assembly option).

Table 9 X21 Pinout

| Pin | Description |
|---------------|-------------|
| Center Pin | +12V |
| Sleeve/Barrel | GND |

X21

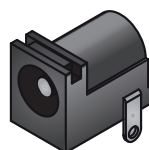

Connector Type

X21: DC power jack, 5.5x2.5 mm diameter

5.1.2 2-Pin Power Connector

The conga-PA7 provides a 2-pin power connector (X22), protected against short transient overvoltage and ESD. Alternatively, this connector can be used as a +12V power output instead.

Table 10 X22 Pinout

| Pin | Description |
|-----|-------------|
| 1 | +12V |
| 2 | GND |

X22

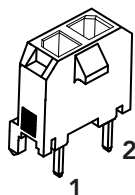

Connector Type

X22: 2x1 pins, 3.00 mm pitch (Molex 43650-0217); Possible Mating Connector: Molex 436450-0200

5.1.3 USB Type-C® Port

The conga-PA7 can be powered via the USB Type-C® port (X9).

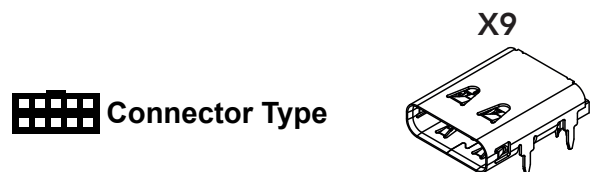

X9: USB Type-C® Port



Note
The USB power adapter must supply 12V and enough current for the intended use case (min. 3 A is recommended). Many USB power adapters only supply 5V. The conga-PA7 will not power up if the USB power adapter only supplies 5V.

5.2 Cell Battery Header

The conga-PA7 provides a CR2032 cell battery (BR2330A for industrial variants) connected to header X23.

Table 11 X23 Pinout

| Pin | Description |
|-----|-------------|
| 1 | +3V |
| 2 | GND |



Connector Type

X23: 2x1 pins, 1.25 mm pitch (Molex 53398-0271); Possible Mating Connector: Molex 51021-0200



Warning

Danger of explosion if battery is incorrectly replaced. Replace only with same or equivalent type recommended by the manufacturer. Dispose of used batteries according to the manufacturer's instructions.



Note
The battery has an adhesive tape on its shrinking tube. This tape enables the system integrator to adequately position the battery in the system case. The functionality of adhesive tape is time limited if exposed to higher temperatures and harsh or vibrant environment. The system integrator must ensure a stable position in this case.

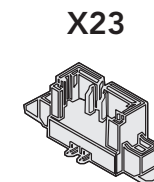
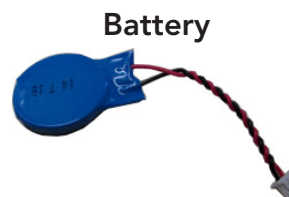

5.3 System State LED

The conga-PA7 provides an onboard bi-color LED (D20) at the top side that indicates the system state as described in the table below:

Table 12 D20 Description

| LED | System State |
|--------------------------------|---------------|
| Green | S0 (Working) |
| Orange | S3 (Sleeping) |
| Green + Orange (low intensity) | S5 (Soft Off) |

5.4 Audio Header

The conga-PA7 provides an HD audio header (X6). The signals are routed from an HD audio codec (TSI 92HD91B).

Table 13 X6 Pinout

| Pin | Default Signal | Description |
|-----|----------------|--|
| 1 | MIC_L | Analog Microphone Input - Left Channel |
| 2 | GND_HDA | Audio Ground |
| 3 | MIC_R | Analog Microphone Input - Right Channel |
| 4 | +V5 | +5V Power Supply (for external speaker amplifier; max. 1 A shared with pin 10) |
| 5 | MIC_JD | Microphone Jack Detection |
| 6 | HP_R | Headphone Line Out - Right Channel |
| 7 | GND_HDA | Audio Ground |
| 8 | HP_L | Headphone Line Out - Left Channel |
| 9 | HP_JD | Headphone Jack Detection |
| 10 | +V5 | +5V Power Supply (for S/PDIF optical transmitter; max. 1 A shared with pin 4) |
| 11 | GND | Digital Ground for S/PDIF and an external class-D amplifier |
| 12 | SPDIF_OUT | S/PDIF Output (3.3V) |

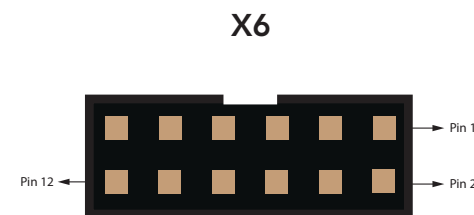

Connector Type

X6: 6x2 pins, 2.0 mm pitch, box header

5.5 USB Interfaces

The conga-PA7 provides two USB Type-A ports, one USB Type-C® port, and one header for two additional USB 2.0 ports. USB 2.0 signals are also routed to the M.2 Key-B (X10) and M.2 Key-E (X11) connectors.

5.5.1 USB Type-A Ports

The conga-PA7 provides two USB Type-A ports (X7) with support for USB 3.1 Gen 2 (up to 10 Gbps) and USB wake (configurable in BIOS menu). Each port can supply up to 1 A.

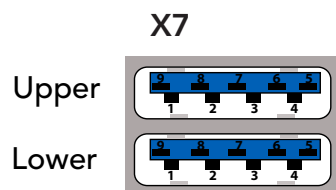

Connector Type

X7: Dual-stacked USB Type-A Ports

5.5.2 USB Type-C® Port

The conga-PA7 provides one USB Type-C® port (X9) with support for:

- USB 3.1 Gen 2 (up to 10 Gbps)
- Power Delivery (up to 5V @ 3A)
- DP Alt Mode (up to 4K @ 60Hz with a 4-lane adapter)
- USB wake

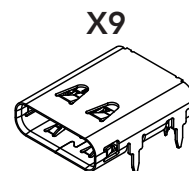

Connector Type

X9: USB Type-C® Port

5.5.3 USB 2.0 Header

The conga-PA7 provides a header (X8) for two external USB 2.0 ports with support for USB wake (configurable in BIOS menu).

Table 14 X8 Pinout

| Port 1 | | | Port 2 | | |
|--------|--------|---|--------|--------|---|
| Pin | Signal | Description | Pin | Signal | Description |
| 1 | +5V | +5V supply | 2 | +5V | +5V supply |
| 3 | Data1- | Hi-speed differential signal (negative) | 4 | Data2- | Hi-speed differential signal (negative) |
| 5 | Data1+ | Hi-speed differential signal (positive) | 6 | Data2+ | Hi-speed differential signal (positive) |
| 7 | GND | Ground | 8 | GND | Ground |
| 9 | SH | Shield Ground | 10 | SH | Shield Ground |

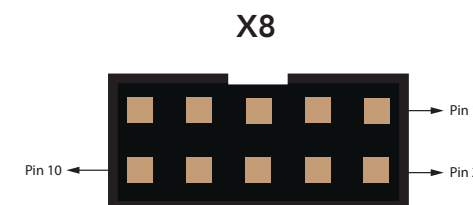

Connector Type

X8: 5x2 pins, 2.00 mm pitch (Molex 87832-1014); Possible Mating Connector: Molex 51110-1051

5.6 Ethernet Ports

The conga-PA7 provides two Ethernet ports (X12, X13) with support for:

- Gigabit Ethernet (GbE)
- Wake-on-LAN (WOL)
- Time-Sensitive Networking (TSN)
- Out-Of-Band Management (OOB)

Note

The real-time trigger signals are provided on feature connector X20. For more information, see section 6.1.3 "GPIOs and Real-Time Trigger Signals".

Table 15 X12, X13 Description

| LED Left Side | Description | LED Right Side | Description |
|---------------|----------------------|----------------|--|
| Off | 10 Mbps link speed | Off | No link |
| Green | 100 Mbps link speed | Steady On | Link established, no activity detected |
| Orange | 1000 Mbps link speed | Blinking | Link established, activity detected |

X12, X13

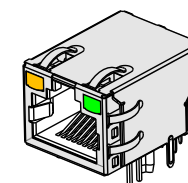

Connector Type

X12, X13: 8-pin RJ45 connector with Gigabit magnetic and LEDs

5.7 Display Interfaces

The conga-PA7 supports up to three displays via one DP++ port, one DP over USB Type-C® port, and one LVDS header.

5.7.1 DP++ Port

The conga-PA7 provides one DP++ port (X5) with support for up to 4K @ 60Hz (DP 1.4).

X5

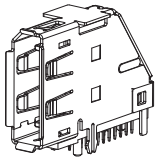

Connector Type

X5: Full-Size DisplayPort Connector

5.7.2 USB Type-C® Port

The conga-PA7 provides one USB Type-C® port (X9) with support for DP Alt Mode up to 4K @ 60Hz.

X9

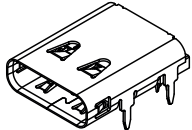

Connector Type

X9: USB Type-C® port

5.7.3 LVDS Header

The conga-PA7 provides an LVDS header (X3) via an eDP to LVDS bridge by default. It supports 18/24-bit single/dual channel, selectable LCD voltage, VESA color mappings, automatic panel detection and resolution up to 1920x1200 @ 60 Hz in dual LVDS mode.

If eDP or MIPI-DSI is required instead of LVDS, contact congatec technical support.

Table 16 X3 Pinout

| Pin | Signal | Pin | Signal |
|-----|---|-----|---|
| 1 | GND | 2 | GND |
| 3 | LVDS_EVEN_TX3P / eDP_TX3P | 4 | LVDS_ODD_TX3P |
| 5 | LVDS_EVEN_TX3N / eDP_TX3N | 6 | LVDS_ODD_TX3N |
| 7 | GND | 8 | GND |
| 9 | LVDS_EVEN_TX2P / eDP_TX2P | 10 | LVDS_ODD_TX2P |
| 11 | LVDS_EVEN_TX2N / eDP_TX2N | 12 | LVDS_ODD_TX2N |
| 13 | GND | 14 | GND |
| 15 | LVDS_EVEN_TX1P / eDP_TX1P | 16 | LVDS_ODD_TX1P |
| 17 | LVDS_EVEN_TX1N / eDP_TX1N | 18 | LVDS_ODD_TX1N |
| 19 | GND | 20 | GND |
| 21 | LVDS_EVEN_TX0P / eDP_TX0P | 22 | LVDS_ODD_TX0P |
| 23 | LVDS_EVEN_TX0N / eDP_TX0N | 24 | LVDS_ODD_TX0N |
| 25 | GND | 26 | GND |
| 27 | LVDS_EVEN_CLKP / eDP_AUXP | 28 | LVDS_ODD_CLKP |
| 29 | LVDS_EVEN_CLKN / eDP_AUXN | 30 | LVDS_ODD_CLKN |
| 31 | GND | 32 | GND |
| 33 | DDC_DAT (EDID, 3.3V level bidirectional) | 34 | DDC_CLK (EDID, 3.3V level output) |
| 35 | VCC (+3.3V or +5V, fuse with 1A hold current) | 36 | VCC (+3.3V or +5V, fuse with 1A hold current) |
| 37 | +3.3V for EDID (optional) | 38 | VCC (+3.3V or +5V, fuse with 1A hold current) |
| 39 | VDDEN (output, 3.3V level) | 40 | eDP_HPDP# (optional) |

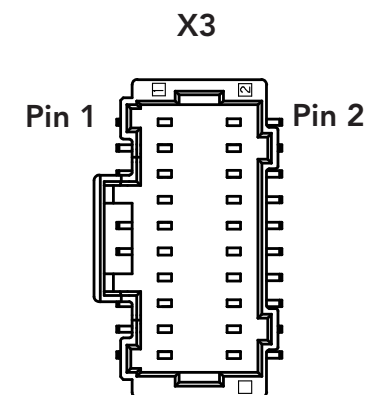

Connector Type

X3: 40 pins, 1.00 mm pitch (Molex 501190-4017); Possible Mating Connector: Molex 501189-4010

Note

1. For a single channel LVDS panel, use the LVDS_ODD pins.
2. congatec offers an LVDS cable for 17" AUO Optonics G170EG01 V.1 panel only (see section Table 4 "Cables").

5.7.3.1 Backlight Power Header

The conga-PA7 provides a backlight power header (X4) with support for 12V and 5V.

Table 17 X4 Pinout

| Pin | Signal | Description |
|-----|------------|-------------------------------|
| 1 | +12V | 12V Backlight inverter power |
| 2 | +12V | 12V Backlight inverter power |
| 3 | GND | Ground |
| 4 | GND | Ground |
| 5 | BKLTCTL_5V | Backlight PWM control (+5V) |
| 6 | BKLTEN_5V | Backlight Enable (+5V) |
| 7 | BKLTEN | Backlight Enable (+3.3V) |
| 8 | BKLTCTL | Backlight PWM control (+3.3V) |
| 9 | +5V | Power rail with +5V |
| 10 | +5V | Power rail with +5V |

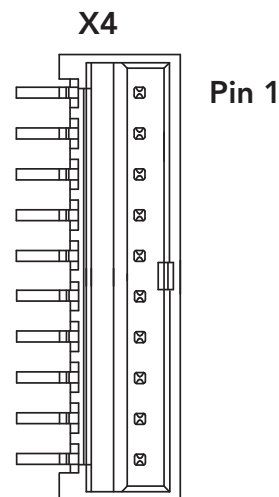

Connector Type

X4: 10x1 pins, 1.5 mm pitch (Molex 87437-1043); Possible Mating Connector: Molex 87439-1000

Note

Pin 1 and 2 share a 1.5 A resettable fuse. Pin 9 and 10 share a 1.1 A resettable fuse.

5.7.3.2 Panel Power Jumper

The conga-PA7 supports 3.3V and 5V LVDS panels. Set the panel voltage (X3 pins 35, 36, and 38) with jumper X24.

Table 18 X24 Settings

| Pin | Setting |
|-------|---------|
| 1 - 2 | 3.3V |
| 2 - 3 | 5V |

X24



Connector Type

X24: 3x1-pin, 2.00 mm pitch

5.8 COM Ports

The conga-PA7 provides two COM ports (X15, X16) on the bottom side. Both ports are routed from the congatec Board Controller (cBC) through a transceiver (ISL3333) and support RS232, RS422, and RS485.

Table 19 X15, X16 Pinout

| Pin | RS232 Signal | RS422 / RS485 Signal |
|-----|--------------|----------------------|
| 1 | GND | GND |
| 2 | TXD | TX- |
| 3 | RTS# | TX+ |
| 4 | CTS# | RX+ |
| 5 | RXD | RX- |

X15, X16

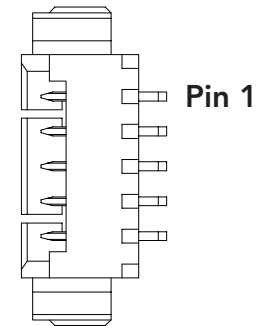

Connector Type

X15, X16: 5x1 pins, 1.25 mm pitch (Molex 53261-0571); Possible Mating Connector: Molex 51021-0500



Caution

1. If termination is required, a 120 Ohm termination resistor must be added externally across pin 4 (RX+) and 5 (RX-).
2. For RS485 mode, TX and RX signals must be coupled externally.



Note

1. The port modes can be configured in the BIOS setup menu (default mode: RS232).
2. RS485 mode provides echo cancellation.
3. RS422 and RS485 modes do not provide galvanic isolation.
4. RS485 mode uses Automatic Direction Control and it is based on a delay circuit triggered by the TXD signal. Therefore, a small delay is present after sending data and before TX output of the transceiver is disabled (typ. 2ms).
5. RS485 mode supports transfer rate 9600kbps or higher. Lower transfer rates are not supported by design.
6. congatec offers adapter cables for the COM port headers. For more information, see Table 4.

5.9 CAN Ports

Optionally, the conga-PA7 can provide two CAN ports (X1, X2) on the bottom side (assembly option) with support for:

- ISO 11898-1 (Identical to Bosch CAN protocol specification 2.0 part A, B)
- ISO 11898-4 (Time-triggered communication)
- CAN FD protocol specification 1.0

Both ports are connected to the SoC via a transceiver (TCAN1046V-Q1) and share a resettable 500 mA fuse.

Table 20 X1, X2 Pinout

| Pin | Signal |
|-----|---|
| 1 | +12V (shared 500 mA fuse for X1 and X2) |
| 2 | CAN H |
| 3 | CAN L |
| 4 | GND |

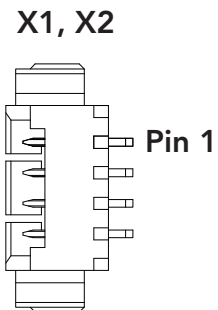

Connector Type

X1, X2: 4x1 pins, 1.25 mm pitch (Molex 53261-0471); Possible Mating Connector: Molex 51021-0400



Caution

A 120 Ohm termination resistor must be added externally across pin 2 (CAN H) and 3 (CAN L).



Note

The silicon vendor supports CAN ports in Yocto Operating System only.

5.10 M.2 Key-B

The conga-PA7 provides an M.2 Key-B connector (X10) for 2280 sized cards with support for PCIe Gen3 x2, SATA 6 Gb/s, and USB 2.0. Optionally, the conga-PA7 can support 3042/2242 sized cards instead (assembly option).

Table 21 X10 Pinout

| Pin | Signal | Pin | Signal |
|-----|--|-----|------------------|
| 2 | 3.3V | 1 | CONFIG_3 |
| 4 | 3.3V | 3 | GND |
| 6 | FULL_CARD_POWER_OFF# (O)(0/1.8V or 3.3V) | 5 | GND |
| 8 | W_DISABLE1# (O)(0/3.3V) | 7 | USB_D+ |
| 10 | NC | 9 | USB_D- |
| | Key-B | 11 | GND |
| | Key-B | | Key-B |
| | Key-B | | Key-B |
| | Key-B | | Key-B |
| | Key-B | | Key-B |
| 20 | NC | 21 | NC |
| 22 | NC | 23 | NC |
| 24 | NC | 25 | NC |
| 26 | NC | 27 | GND |
| 28 | NC | 29 | PERn1 |
| 30 | NC | 31 | PERp1 |
| 32 | NC | 33 | GND |
| 34 | NC | 35 | PETn1 |
| 36 | NC | 37 | PETp1 |
| 38 | DEVSLP (O) | 39 | GND |
| 40 | NC | 41 | PERn0 / SATA RX+ |
| 42 | NC | 43 | PERp0 / SATA RX- |
| 44 | NC | 45 | GND |
| 46 | NC | 47 | PETn0 / SATA TX- |
| 48 | NC | 49 | PETp0 / SATA TX+ |
| 50 | PERST# (O) (0/3.3V) | 51 | GND |
| 52 | CLKREQ# (I/O) (0/3.3V) | 53 | REFCLKn |

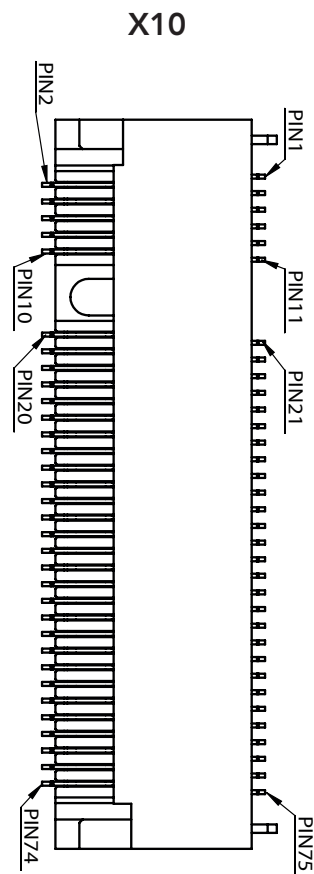

| | | | |
|----|-------|----|--------------------|
| 54 | NC | 55 | REFCLKp |
| 56 | NC | 57 | GND |
| 58 | NC | 59 | NC |
| 60 | COEX3 | 61 | NC |
| 62 | COEX2 | 63 | NC |
| 64 | COEX1 | 65 | NC |
| 66 | NC | 67 | RESET# (O)(0/1.8V) |
| 68 | NC | 69 | CONFIG_1 |
| 70 | 3.3V | 71 | GND |
| 72 | 3.3V | 73 | GND |
| 74 | 3.3V | 75 | CONFIG_2 |

Connector Type

X10: M.2 Key-B Connector



I/O directions are for the conga-PA7 and not a card.

5.11 M.2 Key-E

The conga-PA7 provides an M.2 Key-E connector (X11) for 2230 sized cards with support for PCIe Gen3 x1 and USB 2.0.

Table 22 X11 Pinout

| Pin | Signal | Pin | Signal |
|-----|----------------|-----|--------|
| 2 | 3.3V | 1 | GND |
| 4 | 3.3V | 3 | USB_D+ |
| 6 | LED_1# (I)(OD) | 5 | USB_D- |
| 8 | NC | 7 | GND |
| 10 | NC | 9 | NC |
| 12 | NC | 11 | NC |
| 14 | NC | 13 | NC |
| 16 | NC | 15 | NC |
| 18 | GND | 17 | NC |
| 20 | NC | 19 | NC |

| | | | |
|----|-------------------------|----|------------------------|
| 22 | NC | 21 | NC |
| | Key-E | 23 | NC |
| | Key-E | | Key-E |
| | Key-E | | Key-E |
| | Key-E | | Key-E |
| | Key-E | | Key-E |
| 32 | NC | 33 | GND |
| 34 | NC | 35 | PETp0 |
| 36 | NC | 37 | PETn0 |
| 38 | NC | 39 | GND |
| 40 | NC | 41 | PERp0 |
| 42 | NC | 43 | PERn0 |
| 44 | COEX3 | 45 | GND |
| 46 | COEX2 | 47 | REFCLKp0 |
| 48 | COEX1 | 49 | REFCLKn0 |
| 50 | NC | 51 | GND |
| 52 | PERST0# (O)(0/3.3V) | 53 | CLKREQ0# (I/O)(0/3.3V) |
| 54 | W_DISABLE2# (O)(0/3.3V) | 55 | PEWAKE0# (I/O)(0/3.3V) |
| 56 | W_DISABLE1# (O)(0/3.3V) | 57 | GND |
| 58 | NC | 59 | NC |
| 60 | NC | 61 | NC |
| 62 | NC | 63 | GND |
| 64 | NC | 65 | NC |
| 66 | NC | 67 | NC |
| 68 | NC | 69 | GND |
| 70 | NC | 71 | NC |
| 72 | 3.3V | 73 | NC |
| 74 | 3.3V | 75 | GND |

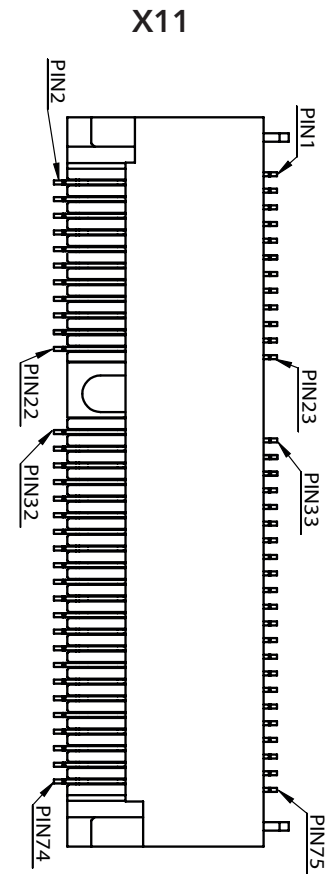

Connector Type

X11: M.2 Key-E Connector

Note

I/O directions are for the conga-PA7 and not a card.

5.12 CPU Fan Header

The conga-PA7 provides a standard 4-pin 12V CPU fan header (X17) with support for PWM control and tachometer.

Table 23 X17 Pinout

| Pin | Signal |
|-----|---------------------------------|
| 1 | GND |
| 2 | +12VDC (resettable 500 mA fuse) |
| 3 | FAN_TACHOIN |
| 4 | FAN_CTRL |

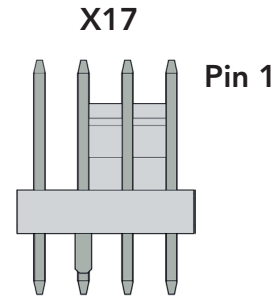

Connector Type

X17: Standard 4-pin, 2.54 mm pitch fan header

5.13 BIOS Flash Header

The conga-PA7 provides a BIOS flash header (X14) for debug and service purposes only.

Table 24 X14 Pinout

| Pin | Signal | Pin | Signal |
|-----|-----------|-----|-----------|
| 1 | CS0# | 2 | +1.8V |
| 3 | MISO | 4 | IO3 |
| 5 | IO2 | 6 | CLK |
| 7 | GND | 8 | MOSI |
| 9 | BIOS_ALT# | 10 | UART1_TXD |

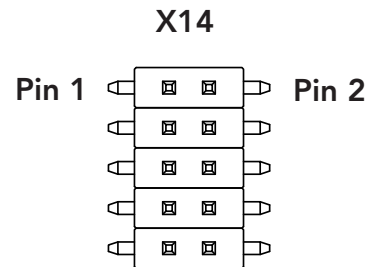

Connector Type

X14: 5x2 pins, 1.27 mm pitch

6 Additional Features

6.1 Feature Connectors

The conga-PA7 provides three feature connectors (X18, X19, and X20).

6.1.1 Buttons and LEDs

The conga-PA7 offers lid, sleep, reset, power buttons, and LED signals via the feature connector X18 as described in the table below:

Table 25 X18 Pinout

| Pin | Default Signal | Assembly Option | Description |
|-----|---|---------------------|---|
| 1 | LID_BTN# | INTRUDER# | Active-low signal brings the system into sleep state or wakes it up. Requires an ACPI compatible operating system. Assembly option: Connect to INTRUDER# of SoC. |
| 2 | GND | | Ground |
| 3 | SLP_BTN# | | Active-low signal triggers sleep state. |
| 4 | GND | | Ground |
| 5 | RST_BTN# | | Active-low signal triggers hard reset. Does not keep the system in reset when connected to ground. |
| 6 | GND | | Ground |
| 7 | PWR_BTN# | | Active-low signal triggers power-up sequence. Pulse duration of ≥ 4 seconds triggers forced shutdown. Signal can also be triggered by the cBC depending on BIOS settings (see section 6.4.2 "Power Loss Control"). |
| 8 | GND | | Ground |
| 9 | Main color LED (anode) / Alt color LED (cathode) | | Bidirectional power LED is supported. Main color indicates runtime mode (S0). Alternate color indicates sleep mode (S3, suspend to RAM). |
| 10 | Main color LED (cathode) / Alt color LED (anode) | | |
| 11 | WiFi_LED (anode) | WWAN_LED (anode) | LED indicates activity on M.2 Key-E interface. |
| 12 | WiFi_LED# (cathode) | WWAN_LED# (cathode) | Assembly option: LED indicates activity on M.2 Key-B interface. |

X18

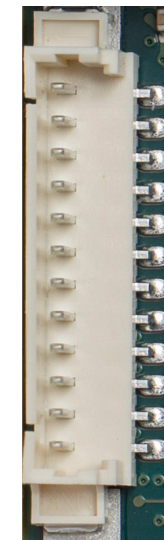

Pin 1

Connector Type

X18: 12x1 pins, 1.25 mm pitch (Molex 53398-1271); Possible Mating Connector: Molex 51021-1200

Note

1. The LEDs on the conga-PA7 are supplied by +3.3 V with 324 Ohm series resistors. LED terminals can be directly to the X18 pins.
2. The buttons are edge triggered with 16 ms debouncing and can be directly connected to a tactile switch or OC output.

6.1.2 I2C and Watchdog

The conga-PA7 provides I2C, batlow, and watchdog signals via the feature connector X19 as described in the table below:

Table 26 X19 Pinout

| Pin | Default Signal | Assembly Option | Description |
|-----|----------------|-----------------|---|
| 1 | BATLOW# | | Battery low input, 10k PU to +3.3V standby, OC or OD output must be used to drive the signal, active low. |
| 2 | +3.3V Standby | | +3.3V power output (active in standby/suspend) |
| 3 | PM THRM# | PLT RST# | External event signal (thermal event), 10k PU to +3.3V runtime, OC or OD output must be used to drive the signal, active low. Assembly option: Platform reset signal output, active low. |
| 4 | I2C_CLK | | I2C clock output |
| 5 | I2C_DAT | | I2C data |
| 6 | GND | | Ground |
| 7 | WDTRIG# | SLP S3# | Watchdog trigger input signal, 10k PU to +3.3V runtime, OC or OD output is recommended to use, active low. Assembly option: SLP S3 output, active low. |
| 8 | WDOUT | SLP S4# | Watchdog output from board controller, 100k PD. Assembly option: SLP S4 output, active low. |

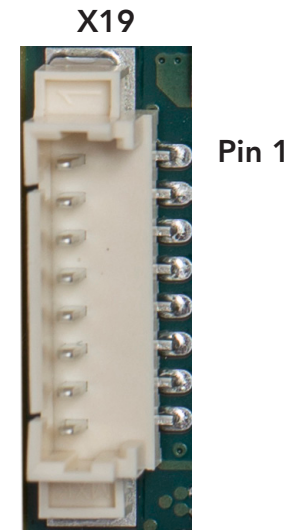

Connector Type

X19: 8x1 pins, 1.25 mm pitch (Molex 53398-0871); Possible Mating Connector: Molex 51021-0800

Note

1. A resettable fuse limits the 3.3V power budget of connector X19 (pin 2) and X20 (pin 10) to a total of 500 mA hold current.
2. The signals are 3.3V compatible.

6.1.3 GPIOs and Real-Time Trigger Signals

The conga-PA7 provides GPIOs and real-time trigger signals via the feature connector X20 as described in the table below:

Table 27 X20 Pinout

| Pin | Default Signal | Assembly Option | Description |
|-----|----------------|-----------------|---|
| 1 | GPIO 0 | | GPIO 0 from board controller, 10k PU to +3.3V standby. |
| 2 | GPIO 1 | | GPIO 1 from board controller, 10k PU to +3.3V standby. |
| 3 | GPIO 2 | | GPIO 2 from board controller, 10k PU to +3.3V standby. |
| 4 | GPIO 3 | | GPIO 3 from board controller, 10k PU to +3.3V standby. |
| 5 | GND | | Ground |
| 6 | GPIO 4 | | GPIO 4 from board controller, 10k PU to +3.3V standby. |
| 7 | GPIO 5 | | GPIO 5 from board controller, 10k PU to +3.3V standby. |
| 8 | GbE0 TRIG | GPIO 6 | IEEE 1588 trigger signal output, GbE 0 port. Assembly Option: GPIO 6 from board controller, 10k PU to +3.3V standby. |
| 9 | GbE1 TRIG | GPIO 7 | IEEE 1588 trigger signal output, GbE 1 port. Assembly Option: GPIO 7 from board controller, 10k PU to +3.3V standby. |
| 10 | +3.3V standby | | +3.3V power output (active in standby/suspend). |

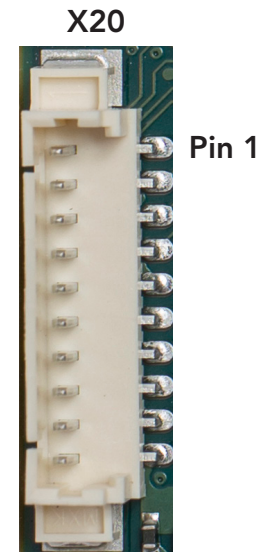

Connector Type

X20: 10x1 pins, 1.25 mm pitch (Molex 53398-1071); Possible Mating Connector: Molex 51021-1000

Note

A fuse limits the 3.3V power budget of connector X19 (pin 2) and X20 (pin 10) to a total of 500 mA hold current.

6.2 DRAM

The conga-PA7 provides onboard LPDDR4x memory. The default memory size and speed of each variant is listed in section 1.2 "conga-PA7". Optionally, the conga-PA7 can provide up to 16 GB LPDDR4x @ 3.733 MT/s (assembly option).

6.3 Flash Storage

The conga-PA7 provides onboard eMMC 5.1 flash storage. The default storage capacity of each variant is listed in section 1.2 "conga-PA7". Optionally, the conga-PA7 can provide up to 128 GB flash storage (assembly option).

6.4 congatec Board Controller (cBC)

The conga-PA7 is equipped with a Microchip Technology microcontroller. This onboard microcontroller plays an important role for most of the congatec BIOS features. The cBC fully isolates some of the embedded features such as system monitoring, I²C bus from the x86 core architecture. This improves performance and reliability, even during low power mode.

6.4.1 Fan Control

The congatec Board Controller on the conga-PA7 controls the power supply to the fan with the PWM signal.

6.4.2 Power Loss Control

The cBC provides the power loss control feature. The power loss control feature determines the behaviour of the system after a power loss occurs. The power loss control feature has three different modes that define how the system responds when power is restored after a power loss occurs. The modes are:

- Turn On: The system is turned on after a power loss condition
- Remain Off: The system is kept off after a power loss condition
- Last State: The board controller restores the last state of the system before the power loss condition



Note

1. If a power loss condition occurs within 30 seconds after a regular shutdown, the cBC may incorrectly set the last state to "ON".
2. The 30 seconds monitoring cycle applies only to the "Last State" power loss control mode.

6.4.3 Board Information

The cBC provides a rich data-set of manufacturing and board information such as serial number, EAN number, hardware and firmware revisions, and so on. It also keeps track of dynamically changing data like runtime meter and boot counter.

6.4.4 Enhanced Soft-Off State

The conga-PA7 supports an enhanced Soft-Off state (S5e)—a congatec proprietary low-power Soft-Off state. In this state, the SBC switches off almost all the onboard logic in order to reduce the power consumption to absolute minimum (approximately 1.4 mA).

The S5e supports power button and sleep button wake events. Refer to congatec application note AN36_S5e_Implementation.pdf for detailed description of the S5e state.

6.5 OEM BIOS Customization

The conga-PA7 is equipped with congatec Embedded BIOS, which is based on American Megatrends Inc. Aptio UEFI firmware. The congatec Embedded BIOS allows system designers to modify the BIOS. For more information about customizing the congatec Embedded BIOS, refer to the congatec System Utility user's guide CGUTLm1x.pdf at www.congatec.com or contact technical support. The customization features supported are described in the following sections.

6.5.1 OEM Default Settings

This feature allows system designers to create and store their own BIOS default configuration. Customized BIOS development by congatec for OEM default settings is no longer necessary because customers can easily perform this configuration by themselves using the congatec system utility CGUTIL. See congatec application note AN8_Create_OEM_Default_Map.pdf on the congatec website for details on how to add OEM default settings to the congatec Embedded BIOS.

6.5.2 OEM Boot Logo

This feature allows system designers to replace the standard text output displayed during POST with their own BIOS boot logo. Customized BIOS development by congatec for OEM Boot Logo is no longer necessary because customers can easily perform this configuration by themselves using the congatec system utility CGUTIL. See congatec application note AN8_Create_And_Add_Bootlogo.pdf on the congatec website for details on how to add OEM boot logo to the congatec Embedded BIOS.

6.5.3 OEM POST Logo

This feature allows system designers to replace the congatec POST logo displayed in the upper left corner of the screen during BIOS POST with their own BIOS POST logo. Use the congatec system utility CGUTIL 1.5.4 or later to replace/add the OEM POST logo.

6.5.4 OEM BIOS Code/Data

With the congatec embedded BIOS, it used to be possible for system designers to add their own code to the BIOS POST process. This feature is no longer supported with the new UEFI based firmware.

6.5.5 OEM DXE Driver

This feature allows designers to add their own UEFI DXE driver to the congatec embedded BIOS. Contact congatec technical support for more information on how to add an OEM DXE driver.

6.6 congatec Battery Management Interface

In order to facilitate the development of battery powered mobile systems based on embedded modules, congatec has defined an interface for the exchange of data between a x86 CPU module (using an ACPI operating system) and a Smart Battery system. A system developed according to the congatec Battery Management Interface Specification can provide the battery management functions supported by an ACPI capable operating system (e.g. charge state of the battery, information about the battery, alarms/events for certain battery states, ...) without the need for any additional modifications to the system BIOS.

In addition to the ACPI-compliant Control Method Battery mentioned above, the latest versions of the conga-PA7 BIOS and board controller firmware also support the LTC1760 battery manager from Linear Technology and a battery only solution (no charger). All three battery solutions are supported on the I2C bus. This gives the system designer more flexibility when choosing the appropriate battery sub-system.

For more information about the supported Battery Management Interface contact your local congatec sales representative.

6.7 API Support (CGOS)

In order to benefit from the above mentioned non-industry standard feature set, congatec provides an API that allows application software developers to easily integrate all these features into their code. The CGOS API (congatec Operating System Application Programming Interface) is the congatec proprietary API that is available for all commonly used Operating Systems such as Win32, Win64, Win CE, Linux. The architecture of the CGOS API driver provides the ability to write application software that runs unmodified on all congatec CPU modules. All the hardware related code is contained within the congatec embedded BIOS on the module. See section 1.1 of the CGOS API software developers guide, which is available on the congatec website.

6.8 Thermal/Voltage Monitoring

The congatec Board Controller monitors the +12V input voltage, input current and two onboard thermal sensors. The CPU temperature is measured by its internal sensor.

6.9 External System Wake Event

The conga-PA7 supports USB, LAN, power/sleep/LID buttons and PCIe driven wake up events.

6.10 Security Features

The conga-PA7 provides an onboard TPM 2.0 chip (Infineon SLB9670) connected to the SPI interface.

8 BIOS Setup Description

The BIOS setup description of the conga-PA7 can be viewed without having access to the SBC. However, access to the restricted area of the congatec website is required in order to download the necessary tool (CgMlfViewer) and Menu Layout File (MLF).

The MLF contains the BIOS setup description of a particular BIOS revision. The MLF can be viewed with the CgMlfViewer tool. This tool offers a search function to quickly check for supported BIOS features. It also shows where each feature can be found in the BIOS setup menu.

For more information, read the application note "AN42 - BIOS Setup Description" available at www.congatec.com.



If you do not have access to the restricted area of the congatec website, contact your local congatec sales representative.

8.1 Navigating the BIOS Setup Menu

The BIOS setup menu shows the features and options supported in the congatec BIOS. To access and navigate the BIOS setup menu, press the or <F2> key during POST.

The right frame displays the key legend. Above the key legend is an area reserved for text messages. These text messages explain the options and the possible impacts when changing the selected option in the left frame.

8.2 BIOS Versions

The BIOS displays the BIOS project name and the revision code during POST, and on the main setup screen. The initial production BIOS for conga-PA7 is identified as PA70R1xx, where:

- PA7 is the project name
- R is the identifier for a BIOS ROM file
- 1 is the feature number
- xx is the major and minor revision number.

The binary size of conga-PA7 BIOS is 32 MB.

8.3 Updating the BIOS

BIOS updates are recommended to correct platform issues or enhance the feature set of the SBC. The conga-PA7 features a congatec/AMI AptioEFI firmware on an onboard flash ROM chip. You can update the firmware with the congatec System Utility. The utility has five versions—UEFI shell, DOS based command line¹, Win32 command line, Win32 GUI, and Linux version.

For more information about “Updating the BIOS” refer to the user’s guide for the congatec System Utility “CGUTLm1x.pdf” on the congatec website at www.congatec.com.



Note

¹. *Deprecated*



Caution

The DOS command line tool is not officially supported by congatec and therefore not recommended for critical tasks such as firmware updates. We recommend to use only the UEFI shell for critical updates.

8.4 Supported Flash Device

The conga-PA7 supports flash device Winbond W25R256JWPIQ (32 MB). For more information about external BIOS support, refer to the Application Note “AN7_External_BIOS_Update.pdf” on the congatec website at www.congatec.com.

Our company network supports you worldwide with offices in Germany, Austria, Switzerland, the UK and the USA. For more information please contact:

Headquarters

Germany



FORTEC Elektronik AG
Augsburger Str. 2b
82110 Germering

Phone: +49 89 894450-0
E-Mail: info@fortecag.de
Internet: www.fortecag.de

Fortec Group Members

Austria



FORTEC Integrated GmbH,
Office Vienna
Nuschinggasse 12
1230 Wien

Phone: +43 1 8673492-0
E-Mail: info@fortec-integrated.de
Internet: www.fortec-integrated.de

Germany



FORTEC Integrated GmbH
Augsburger Str. 2b
82110 Germering

Phone: +49 89 894363-0
E-Mail: info@fortec-integrated.de
Internet: www.fortec-integrated.de

Switzerland



FORTEC Switzerland AG
Bahnhofstraße 3
5436 Würenlos

Phone: +41 44 7446111
E-Mail: info@fortec.ch
Internet: www.fortec.ch

United Kingdom



FORTEC Technology UK Ltd.
Osprey House, 1 Osprey Court
Hinchingsbrooke Business Park
Huntingdon, Cambridgeshire, PE29 6FN

Phone: +44 1480 411600
E-Mail: info@fortec.uk
Internet: www.fortec.uk

USA



Apollo Display Technologies, Corp.
87 Raynor Avenue,
Unit 1Ronkonkoma,
NY 11779

Phone: +1 631 5804360
E-Mail: info@apolloDisplays.com
Internet: www.apolloDisplays.com