



OUR GLOBAL
COMPETENCE
CENTRES

 APOLLO DISPLAY
TECHNOLOGIES



 DISTEC



 DISPLAY
TECHNOLOGY



Manual

Diamond Systems

Aries

Single Board Computer PC/104 CPU Module with Intel quad core E3845 or 1.46GHz dual core E3826 Bay
Trail Processors

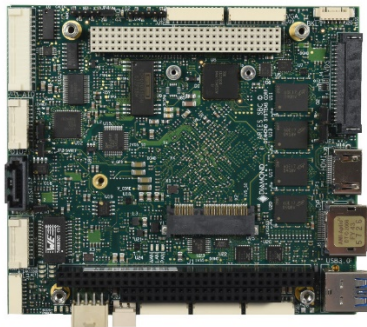

The information contained in this document has been carefully researched and is, to the best of our knowledge, accurate. However, we assume no liability for any product failures or damages, immediate or consequential, resulting from the use of the information provided herein. Our products are not intended for use in systems in which failures of product could result in personal injury. All trademarks mentioned herein are property of their respective owners. All specifications are subject to change without notice.



Aries Single Board Computer

PC/104-Plus SBC with Intel E3800 “Bay Trail” Processor



Revision	Date	Comment
A.00	3/26/2015	Initial Release
A.01	8/26/2015	JP4 update and minor changes
A.02	11/3/2015	Section 8.5 removed
A.03	4/5/2016	BIOS & memory sizing information added
A.04	11/30/16	Linux I/O Space & IRQs information added
A.05	4/19/17	AC Power Adapter information removed
A.06	9/21/17	Battery Connector Update
A.07	4/23/18	Update new connector part numbers
A.08	4/27/18	Clarify input power connector information

**FOR TECHNICAL SUPPORT
PLEASE CONTACT:**

support@diamondsystems.com

Copyright 2018
Diamond Systems Corporation
158 Commercial Street
Sunnyvale, CA 94086 USA
Tel 1-650-810-2500
Fax 1-650-810-2525
www.diamondsystems.com

CONTENTS

1. Important Safe Handling Information	4
2. Introduction	6
2.1 Models	6
2.2 Features.....	6
2.3 Operating System Support	7
2.4 Mechanical, Electrical, Environmental.....	7
3. Functional Overview.....	8
3.1 Block Diagram	8
3.2 Feature Descriptions	9
3.2.1 Processor and Memory.....	9
3.2.2 Ethernet.....	9
3.2.3 Video.....	9
3.2.4 SATA.....	9
3.2.5 USB.....	9
3.2.6 Serial Ports	9
3.2.7 Audio.....	9
3.2.8 Data Acquisition	10
3.2.9 Backup Battery.....	10
3.2.10 PCIe MiniCard Socket.....	10
3.2.11 PC/104-Plus Expansion.....	10
3.2.12 PCIe link routing.....	10
3.2.13 Watchdog Timer.....	10
3.2.14 LED Indicators	11
3.2.15 BIOS Features	11
4. Mechanical Board Drawing.....	13
5. Board Layout.....	14
5.1 I/O Connectors, Jumpers and LED Summary	15
6. I/O Connectors	16
6.1 Connector Pin-out and Signal Description	16
6.1.1 PC/104 (J1, J2)	16
6.1.2 PC-104 (J3).....	17
6.1.3 LVDS LCD (J4)	18
6.1.4 HDMI (J5).....	19
6.1.5 Display Port (J6)	19
6.1.6 USB 3.0 Ports (J7)	20
6.1.7 USB 2.0 Ports (J8)	20
6.1.8 Serial ports (J9, J10).....	21
6.1.9 External Battery (J11)	21
6.1.10 Input Power (J12).....	22
6.1.11 Audio (J13).....	22
6.1.12 Ethernet (J14)	23
6.1.13 SATA (J15)	23
6.1.14 Digital I/O (J16)	24
6.1.15 Analog I/O (J17).....	24
6.1.16 Utility Connector (J18)	25
6.1.17 VGA (J19)	26
6.1.18 LCD Backlight (J20).....	26
6.1.19 mSATA / PCIe MiniCard Socket (J21).....	27
6.2 List of Connectors.....	28
7. Jumper Description	29
7.1 LVDS Backlight and LVDS VDD (JP1)	30
7.2 SATA (JP2).....	30
7.3 Digital IO (JP3)	30
7.4 Miscellaneous (JP4)	31
8. BIOS Key Features.....	32
8.1 Entering the BIOS.....	32
8.2 Restoring Default BIOS Settings	32
8.3 Setting the Date and Time.....	32
8.4 Boot Priority	33
8.5 Setting Usable Memory	33

8.6	LED	33
8.7	Quiet / Quick Boot / Splash Screen	33
8.8	Selecting the Displays	33
8.9	Serial Port Configuration	33
9.	Getting Started	34
9.1	Development Kit	34
9.2	Quick Setup	34
9.3	Boot Device Options	34
10.	Data Acquisition Circuit	36
10.1	Overview	36
10.2	FPGA	37
10.3	Bus Interface.....	37
10.4	Interrupts.....	37
11.	A/D Circuit	39
11.1	A/D Input Ranges and Resolution	39
11.2	Unipolar and Bipolar Inputs	39
11.3	Ranges and Resolutions	39
11.3.1	Conversion Formulas	40
11.4	A/D Sampling Methods	41
11.4.1	FIFO Description	41
11.4.2	Scan Sampling	42
11.4.3	Sequential Sampling	42
11.4.4	Sampling Methods	42
12.	D/A Circuit	44
12.1	Ranges and Resolutions	44
12.1.1	Ranges.....	44
12.1.2	Resolution	44
12.2	D/A Conversion Formulas and Tables.....	45
12.2.1	D/A Conversion Formulas for Unipolar Output Ranges.....	45
12.2.2	D/A Conversion Formulas for Bipolar Output Ranges	45
12.3	Calibration.....	47
12.4	Waveform Generator	47
13.	Digital I/O	48
14.	Counters and Timers	49
15.	Pulse Width Modulation	50
16.	Watchdog Timer.....	51
17.	Thermal Solutions.....	52
17.1	Heat Spreader Drawing	52
17.2	Bottom view of Heat Spreader.....	53
17.3	Heat Spreader Installed on the Board	54
17.4	Thermal Pad	55
17.5	Heat Sink Accessory	56
18.	Specifications.....	57
19.	Appendix.....	58

1. IMPORTANT SAFE HANDLING INFORMATION



WARNING!

ESD-Sensitive Electronic Equipment

Observe ESD-safe handling procedures when working with this product.

Always use this product in a properly grounded work area and wear appropriate ESD-preventive clothing and/or accessories.

Always store this product in ESD-protective packaging when not in use.

Safe Handling Precautions

The Aries SBC contains a high number of I/O connectors with connection to sensitive electronic components. This creates many opportunities for accidental damage during handling, installation and connection to other equipment. The list here describes common causes of failure found on boards returned to Diamond Systems for repair. This information is provided as a source of advice to help you prevent damaging your Diamond (or any vendor's) embedded computer boards.

ESD damage – This type of damage is usually almost impossible to detect, because there is no visual sign of failure or damage. The symptom is that the board eventually simply stops working, because some component becomes defective. Usually the failure can be identified and the chip can be replaced.

To prevent ESD damage, always follow proper ESD-prevention practices when handling computer boards.

Damage during handling or storage – On some boards we have noticed physical damage from mishandling. A common observation is that a screwdriver slipped while installing the board, causing a gouge in the PCB surface and cutting signal traces or damaging components.

Another common observation is damaged board corners, indicating the board was dropped. This may or may not cause damage to the circuitry, depending on what is near the corner. Most of our boards are designed with at least 25 mils clearance between the board edge and any component pad, and ground / power planes are at least 20 mils from the edge to avoid possible shorting from this type of damage. However these design rules are not sufficient to prevent damage in all situations.

A third cause of failure is when a metal screwdriver tip slips, or a screw drops onto the board while it is powered on, causing a short between a power pin and a signal pin on a component. This can cause overvoltage / power supply problems described below. To avoid this type of failure, only perform assembly operations when the system is powered off.

Sometimes boards are stored in racks with slots that grip the edge of the board. This is a common practice for board manufacturers. However our boards are generally very dense, and if the board has components very close to the board edge, they can be damaged or even knocked off the board when the board tilts back in the rack. Diamond recommends that all our boards be stored only in individual ESD-safe packaging. If multiple boards are stored together, they should be contained in bins with dividers between boards. Do not pile boards on top of each other or cram too many boards into a small location. This can cause damage to connector pins or fragile components.

Power supply wired backwards – Our power supplies and boards are not designed to withstand a reverse power supply connection. This will destroy each IC that is connected to the power supply (i.e. almost all ICs). In this case the board will most likely will be unrepairable and must be replaced. A chip destroyed by reverse power or by excessive power will often have a visible hole on the top or show some deformation on the top surface due to vaporization inside the package. **Check twice before applying power!**

Board not installed properly in PC/104 stack – A common error is to install a PC/104 board accidentally shifted by 1 row or 1 column. If the board is installed incorrectly, it is possible for power and ground signals on the bus to make contact with the wrong pins on the board, which can damage the board. For example, this can damage components attached to the data bus, because it puts the $\pm 12V$ power supply lines directly on data bus lines.

Overvoltage on analog input – If a voltage applied to an analog input exceeds the design specification of the board, the input multiplexor and/or parts behind it can be damaged. Most of our boards will withstand an erroneous connection of up to $\pm 35V$ on the analog inputs, even when the board is powered off, but not all boards, and not in all conditions.

Overvoltage on analog output – If an analog output is accidentally connected to another output signal or a power supply voltage, the output can be damaged. On most of our boards, a short circuit to ground on an analog output will not cause trouble.

Overvoltage on digital I/O line – If a digital I/O signal is connected to a voltage above the maximum specified voltage, the digital circuitry can be damaged. On most of our boards the acceptable range of voltages connected to digital I/O signals is 0-5V, and they can withstand about 0.5V beyond that (-0.5 to 5.5V) before being damaged. However logic signals at 12V and even 24V are common, and if one of these is connected to a 5V logic chip, the chip will be damaged, and the damage could even extend past that chip to others in the circuit.

Bent connector pins – This type of problem is often only a cosmetic issue and is easily fixed by bending the pins back to their proper shape one at a time with needle-nose pliers. The most common cause of bent connector pins is when a PC/104 board is pulled off the stack by rocking it back and forth left to right, from one end of the connector to the other. As the board is rocked back and forth it pulls out suddenly, and the pins at the end get bent significantly. The same situation can occur when pulling a ribbon cable off of a pin header. If the pins are bent too severely, bending them back can cause them to weaken unacceptably or even break, and the connector must be replaced.

2. INTRODUCTION

Aries is an embedded single board computer (SBC) in the PC/104 form factor. Aries integrates on-board memory, PC/104-*Plus* expansion, one PCIe Mini card socket, dual Gigabit Ethernet and optional data acquisition circuit with analog and digital I/O.

The Aries SBC is based on Intel “Bay Trail” E3800 series processors. The form factor is similar to PC/104 with left and right side extensions that extend the full length of the two sides without providing the corners traditionally seen in PC/104 boards with “wings”.

2.1 Models

<i>Model</i>	<i>Processor/ Speed</i>	<i>Memory</i>	<i>Analog I/O</i>	<i>Digital I/O</i>
ARS3845-4GA	E3845/1.91GHz	4GB DDR3	Yes	Yes
ARS3845-4GN	E3845/1.91GHz	4GB DDR3	No	Yes
ARS3826-2GA	E3826/1.46GHz	2GB DDR3	Yes	Yes
ARS3826-2GN	E3826/1.46GHz	2GB DDR3	No	Yes

2.2 Features

- ◆ 1.91GHz Intel quad core E3845 or 1.46GHz dual core E3826 Bay Trail CPU
- ◆ 2GB or 4GB 64-bit DDR3 SDRAM soldered on board
- ◆ I/O Support:
 - 3 USB 2.0 ports, 1 USB 3.0 port
 - 4 RS-232/422/485 ports with programmable protocol and line termination
 - 2 10/100/1000Mbps Ethernet ports
 - 1 SATA port for disk-on-module or external drive
 - 24-bit LVDS LCD display and VGA CRT
 - DP and HDMI sharing on single channel
 - HD audio
 - Shared expansion socket auto-selects for either PCIe MiniCard or mSATA flash disk modules
 - Programmable watchdog timer
- ◆ Data Acquisition:
 - 16 16-bit analog inputs with 250KHz maximum sample rate
 - 4 16-bit analog outputs with waveform generator
 - 22 digital I/O lines with programmable direction (16 DIO on N models)
 - 8 32-bit counter/timers
 - 4 24-bit PWMs
- ◆ PC/104-*Plus* and PCIe MiniCard expansion capability

2.3 Operating System Support

- ◆ Windows 7, 8, Linux
- ◆ Driver packages and/or BSPs available for each OS

2.4 Mechanical, Electrical, Environmental

- ◆ PC/104 form factor 4.5" x 4.0" (not including I/O connector overhang).
- ◆ -40°C to +85°C ambient operating temperature
- ◆ Power input: +5VDC +/- 5%

3. FUNCTIONAL OVERVIEW

3.1 Block Diagram

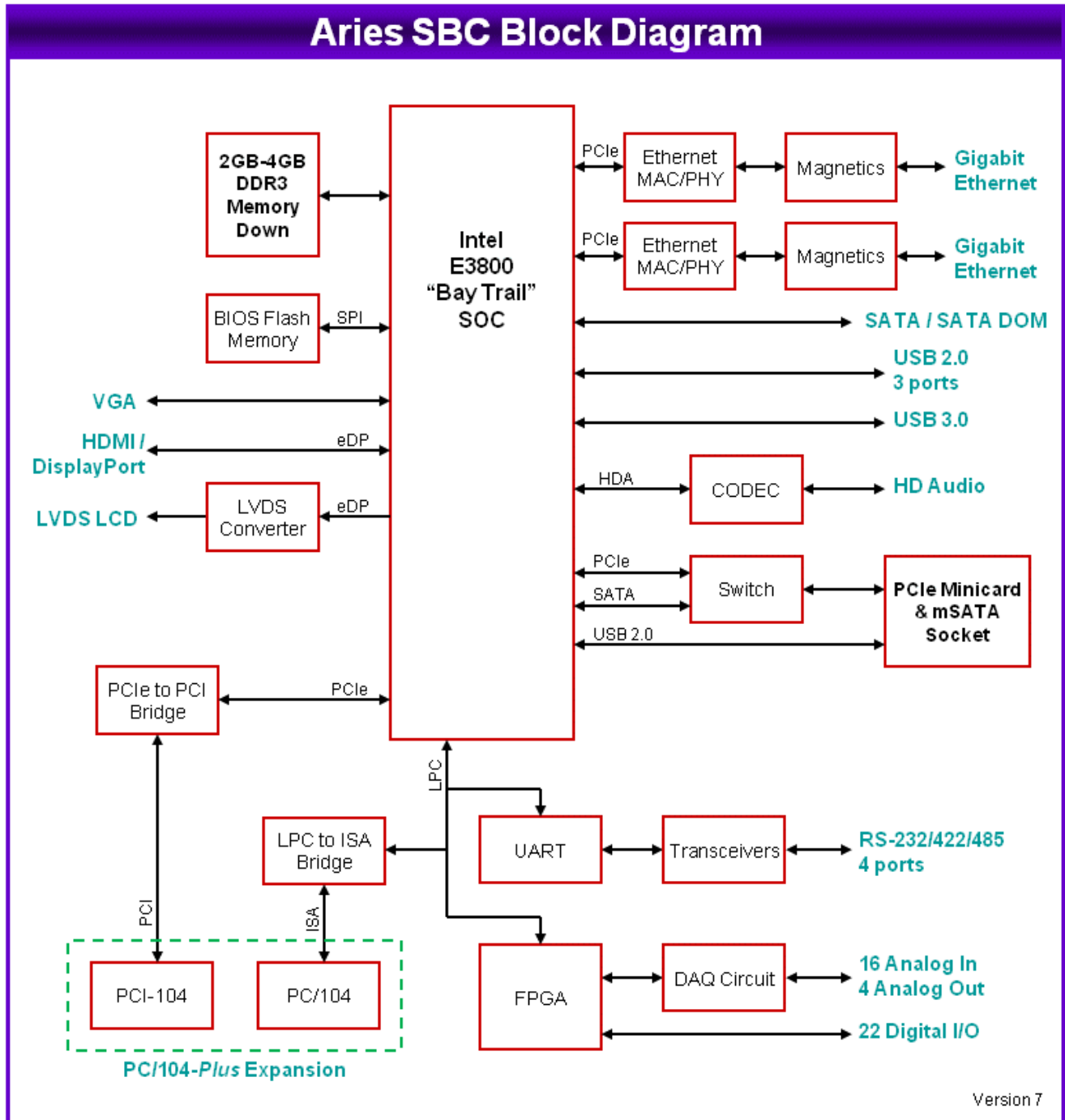

Figure 1: Functional Block Diagram

3.2 Feature Descriptions

This section describes the key subsystems of the Aries SBC.

3.2.1 Processor and Memory

Aries core embedded computer circuit is based on Intel's Bay Trail. Depending on the model chosen the processors speed and its memory will differ. The two different cores available are 1.91GHz quad core Intel E3845 with 4GB DDR3 and 1.46GHz dual core Intel E3826 with 2GB DDR3 memory.

3.2.2 Ethernet

Aries provides two Gigabit Ethernet Ports derived from Intel I210IT PCIe Gigabit Ethernet Controllers (MAC + PHY). The board has been provided with necessary magnetics for the ports. Instead of a standard RJ-45 jack a pin header has been used.

On-board LEDs are provided for Link, Activity, and Speed. The LEDs are located along the board edge near the Ethernet connector. The Ethernet connector does not provide access to the LED signals. However, the LED's can be accessed from the Utility Connector J18.

3.2.3 Video

The processor offers three video output options: 2 DDI and one dedicated VGA. The DDI ports are configurable for either HDMI 1.4, DP 1.1a, or eDP. Any two outputs can be active at any time.

The second DDI port can be configured for either HDMI or DP, and the board's circuit and I/O connector are configured accordingly. Maximum resolution of DP is 2560 x 1600 x 60Hz x 24bpp. Maximum resolution of HDMI is 1920 x 1080 x 60Hz x 24bpp.

The first DDI port can be used in eDP mode and an eDP to LVDS converter provides a dual-channel LVDS LCD output.

Maximum LVDS and VGA resolution is 2560 x 1600 x 60Hz x 24bpp.

The LCD backlight control is provided by a PWM circuit. LCD backlight power and control are on a separate latching connector.

3.2.4 SATA

Aries offers two SATA ports derived from the processor. One port is connected to an industry-standard vertical SATA connector that accepts cables with latching connectors or an on-board SATA-DOM. The second port is dedicated to the combination mSATA / PCIe Mini Card socket.

3.2.5 USB

Aries provides 3 user accessible USB 2.0 ports and one USB 3.0 port coming directly from the processor. Three come directly from the processor. The fourth USB 2.0 port from the processor is connected to the PCIe Mini card socket. All ports have minimum 500mA per port drive capability with short circuit / over current and ESD protection on each port. USB port connected to mini PCIE does not have ESD protection.

The USB 3.0 port uses an industry standard right-angle USB 3.0 connector. The USB 2.0 ports use miniature 1.25mm pitch latching connectors.

3.2.6 Serial Ports

Aries provides four serial ports with varying protocols and signal availability using the Exar XR28V384 LPC UART. RS-232/422/485 protocols are supported with Exar SP335 multiprotocol transceivers, one per port. In RS-232 mode, only signals TX, RX, RTS, and CTS are provided. Protocol selection and TX / RX 121 ohm line termination resistors for RS-422/485 are controlled using GPIO pins from the FPGA and are configurable via BIOS configuration screens as well as via application software. The GPIO pins are controlled from a page in the FPGA register map dedicated for board configuration. Console redirection is available on COM1.

3.2.7 Audio

The design provides HD audio support from ALC892. Audio I/O signals include stereo line in, stereo line out and mono mic in. The audio signals are made available on a latching connector.

3.2.8 Data Acquisition

Aries provides an optional data acquisition sub-circuit containing analog input, analog output, and digital I/O features. This circuit is controlled by an FPGA attached to the processor via the LPC bus. A pin header on the board provides access to JTAG signals for reprogramming the FPGA on the board and in the field.

Type of I/O	Characteristics
Analog Input	16 single-ended/8 differential inputs, 16-bit resolution 250KHz maximum aggregate A/D sampling rate Programmable input ranges/gains: +/-10V, +/-5V, +/-2.5V, +/-1.25V, 0-10V, 0-5V, 0-2.5V 2048 sample A/D FIFO for reliable high-speed sampling
Analog Output	4 analog outputs, 16-bit resolution $\pm 10V$, $\pm 5V$, $\pm 2.5V$, 0-5V and 0-10V output ranges Indefinite short circuit protection on outputs
Digital I/O	22 programmable digital I/O, 3.3V and 5V logic compatible
Counter/Timers	Eight 32-bit counter/timer for A/D sampling rate control

Apart from the characteristics mentioned in the above table DAQ also offers selectable pull up/down resistors, programmable directions, buffered I/O and capability to use a counter/timer and PWM circuits.

3.2.9 Backup Battery

The board does not contain an on-board RTC backup battery. A connector is provided to enable the use of an external battery.

3.2.10 PCIe MiniCard Socket

The board has one full size (51mm length) PCIe MiniCard socket. The socket supports both PCIe MiniCards and mSATA modules. It has a PCIe/mSATA switch controlled by a pin on the socket to select which interface is active. Additionally, a USB port is also available in PCIe MiniCard socket.

3.2.11 PC/104-Plus Expansion

The board offers a full PC/104-Plus expansion socket with both PCI and ISA expansion connectors on the top side of the board. The PCI bus is provided by a PCIe to PCI Bridge. It supports both 5V and 3.3V logic levels configurable with a jumper. The ISA bus is provided by the Fintek F85226AF LPC to ISA Bridge.

3.2.12 PCIe link routing

Lane 1:	Ethernet #1
Lane 2:	Ethernet #2
Lane 3:	PCIe Mini card
Lane 4:	PCIe to PCI bridge for PCI-104 connector

3.2.13 Watchdog Timer

The board contains a watchdog timer (WDT) circuit with programmable delay time derived from the LPC UART. The WDT can be enabled, disabled, and retriggered in software. If the WDT times out before it is retriggered, it will cause a system reset. The watchdog timer circuit timeout period is programmable from 0 to 255 seconds with 1 second or better resolution.

3.2.14 LED Indicators

The board provides the following LED indicators. All LEDs are located near to a board edge or their respective features. The blue LED is located along the lower edge of the board. All LEDs are labeled in silkscreen with their function.

- **Power input:** Green LED when 5VDC is applied
- **Power on:** Green LED when board is powered on
- **Ethernet:** Green LED for Link, activity, and speed for each port

Activity LED	LINK 100 LED	LINK 1000 LED	Description
On	Off	Off	Port is active Speed is 10Mbps
On	On	Off	Port is active Speed is 100Mbps
On	On	On	Port is active Speed is 1GBps

The Activity LED when **Blinking:** Activity on the port.

Solid: Link

LED locations of all the Ethernet LED's on the board are shown in the Board Layout section.

- **Digital I/O:** Blue, driven with reverse logic from +5V, controlled by data acquisition FPGA
- **Programmable LED:** Green, connected to a GPIO line on the processor; this LED is off during power-up and is turned on in the BIOS to indicate a successful system BIOS startup.
- **PCIe Mini Card socket:** 3 green LEDs to support WWAN, WPAN, WLAN signals from the connector

3.2.15 BIOS Features

The BIOS provides the following key features:

- ◆ Boot from LAN (PXE) as well as USB, SATA, and mSATA ports
- ◆ Free boot sequence configuration to allow different boot sequences as first, second and third boot devices
- ◆ Support for various LCD configurations supported by the video chipset (default should be 1024x768)
- ◆ LCD brightness control adjustment
- ◆ Console (display and keyboard) redirection to COM1 port.
- ◆ DSC-configurable default settings in battery-less configurations; the necessary BIOS customization is provided
- ◆ Customizable splash screen
- ◆ Quiet boot option
- ◆ POST message will display "Diamond Systems Corporation" and also display the board name and BIOS version. The BIOS version will be displayed as "Major.Minor-rev – Date Built" format. For example "Version 1.01 – 12-Oct-2012".
- ◆ Enable/disable for individual COM ports.
- ◆ Protocol selection for each of the COM ports to select serial port protocol on SP330 using DIO lines. Default for all ports is RS-232.
- ◆ 121 ohm line termination for serial ports in RS-422/485 protocol.
- ◆ IRQ sharing for COM ports
- ◆ IRQs can be reserved in BIOS for use on ISA bus; a minimum of 2 IRQs can be reserved.
- ◆ Watchdog timer enable/disable and timeout period selection
- ◆ Ethernet MAC address readback on boot-up and in BIOS screens
- ◆ Wake on LAN for on-board Ethernet and mini card socket
- ◆ Field upgradeable via a DOS utility.

3.2.15.1 POWER SUPPLY

The board requires only +5VDC input voltage as per the PC/104 Specification. It supports ACPI pushbutton on/off control. It supports Standby mode. In standby mode the board may be powered on via Wake on LAN feature on at least one Ethernet port.

The 5V supply on the PC-104 and PC/104-Plus connectors is routed directly to the input power connector, so that the board may obtain its input power from either the input power connector or either of these bus connectors. Maximum allowable reflected ripple, measured at the voltage input connector is 50mV p-p.

All required supply voltages for the board are derived from the 5V input. +12V is optional needed only for add-on modules that require it or to drive the LCD backlight. These power supplies are sized to support the highest power E3800 family processor with the highest capacity on-board memory plus have enough reserve capacity to support the below add-on features:

5V	3.3V	Features
2.0A	2.0A	PC/104 and PC/104-Plus add-on modules
	1.5A	PCIe Mini card add-on modules
0.25A		SATA disk module
1.4A	0.7A	LCD power
0.9A		LCD backlight
	0.05A	DAQ connector
	0.05A	Utility connector
1.0A		USB 2.0 ports
0.9A		USB 3.0 port

The PC/104 and PC/104-Plus connectors obtain 5V power from the input connector. The PC/104-Plus connector obtains 3.3V power from the on-board power supply. The +12 pin on the input power connector is optional. It is routed to the +12V pins on the PC/104 and PC/104-Plus connectors as well as the +12V source for the LCD backlight.

5. BOARD LAYOUT

Figure 3: Board Layout

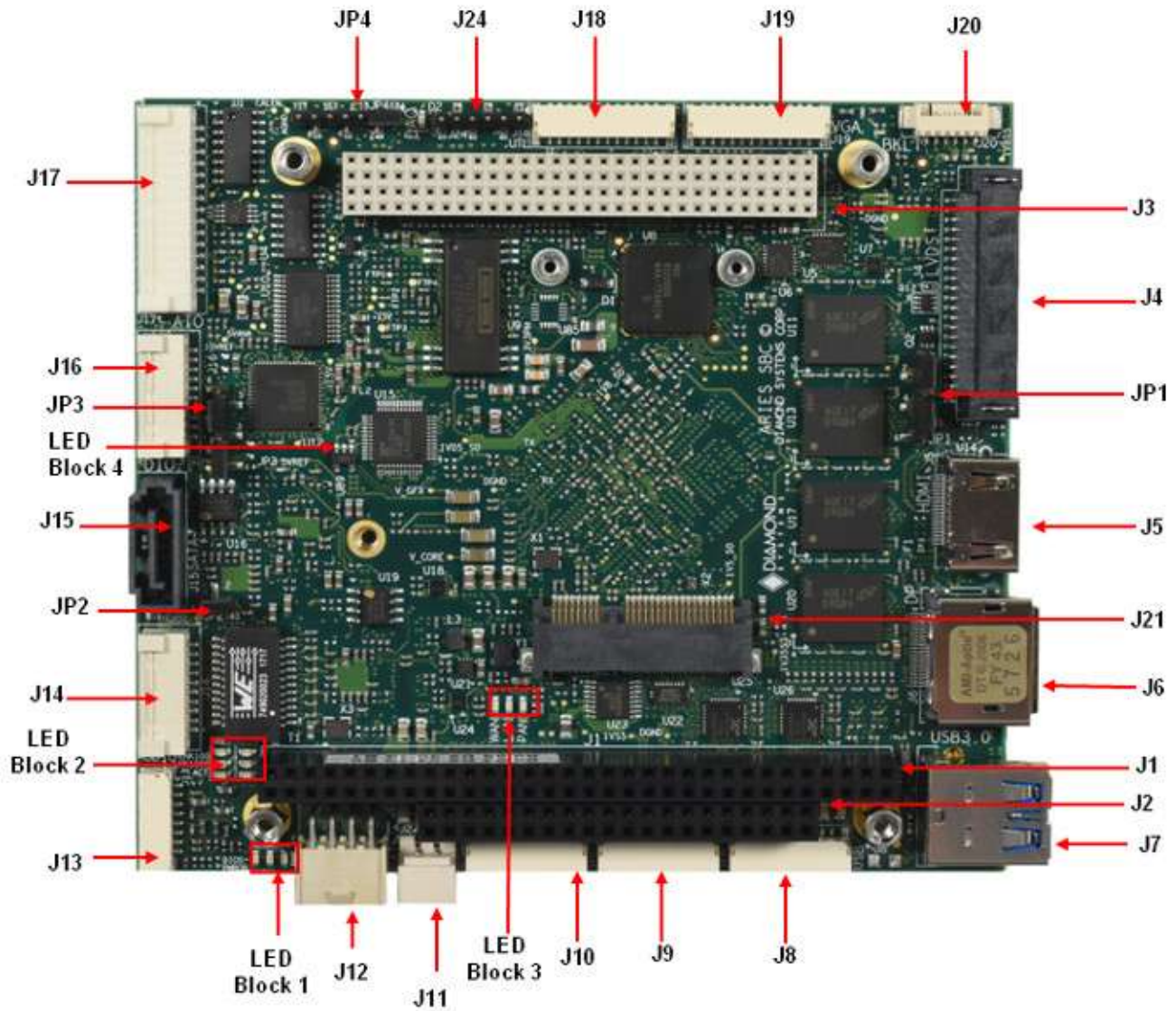

5.1 I/O Connectors, Jumpers and LED Summary

Connector	Function	Jumper	Function
J1	PC/104 - ISA A/B	JP1	LVDS VCC & Backlight
J2	PC/104 - ISA C/D	JP2	SATA DOM
J3	PC/104-Plus - PCI	JP3	Digital VIO
J4	LCD	JP4	Miscellaneous
J5	HDMI	LED Block 1	
J6	DP	1 st LED (Leftmost in the block)	BIOS
J7	USB-3.0	2 nd LED (Middle one in the block)	PWRON
J8	USB-2.0	3 rd LED (Rightmost in the block)	PWRIN
J9	Serial ports 1,2	LED Block 2	
J10	Serial ports 3,4	1 st row 1 st LED	GBE 0 LINK100
J11	External Battery	1 st row 2 st LED	GBE 1 LINK100
J12	Power In	2 nd row 1 st LED	GBE 0 LINK1000
J13	Audio	2 nd row 2 nd LED	GBE 1 LINK1000
J14	Ethernet	3 rd row 1 st LED	GBE 0 ACT
J15	SATA	3 rd row 2 nd LED	GBE 1 ACT
J16	DAQ Digital I/O	LED Block 3	
J17	DAQ Analog I/O	1 st LED (Leftmost in the block)	WAN
J18	Utility	2 nd LED (Middle one in the block)	LAN
J19	VGA	3 rd LED (Rightmost in the block)	PAN
J20	LCD Backlight	LED Block 4	DAQ LED
J21	PCIe Mini-Card		
J22	XTP Connector		
J23	SPI socket for BIOS		
J24	JTAG for FPGA		

6. I/O CONNECTORS

6.1 Connector Pin-out and Signal Description

6.1.1 PC/104 (J1, J2)

The Aries SBC contains the non-stack-through / short pin 8-bit and 16-bit PC/104 connectors on the top side in the standard position as described by the PC/104-Plus specification. Press fit PC/104 connectors have been used.

J2: PC/104 16-bit bus connector

Ground	D0	C0	Ground
MEMCS16-	D1	C1	SBHE-
IOCS16-	D2	C2	LA23
IRQ10	D3	C3	LA22
IRQ11	D4	C4	LA21
IRQ12	D5	C5	LA20
IRQ15	D6	C6	LA19
IRQ14	D7	C7	LA18
DACK0-	D8	C8	LA17
DRQ0	D9	C9	MEMR-
DACK5-	D10	C10	MEMW-
DRQ5	D11	C11	SD8
DACK6-	D12	C12	SD9
DRQ6	D13	C13	SD10
DACK7-	D14	C14	SD11
DRQ7	D15	C15	SD12
+5V	D16	C16	SD13
MASTER-	D17	C17	SD14
Ground	D18	C18	SD15
Ground	D19	C19	Key

J1: PC/104 8-bit bus connector

IOCHCHK-	A1	B1	Ground
SD7	A2	B2	RESET
SD6	A3	B3	+5V
SD5	A4	B4	IRQ9
SD4	A5	B5	-5V
SD3	A6	B6	DRQ2
SD2	A7	B7	-12V
SD1	A8	B8	0WS-
SD0	A9	B9	+12V
IOCHRDY	A10	B10	Key
AEN	A11	B11	SMEMW-
SA19	A12	B12	SMEMR-
SA18	A13	B13	IOW-
SA17	A14	B14	IOR-
SA16	A15	B15	DACK3-
SA15	A16	B16	DRQ3
SA14	A17	B17	DACK1-
SA13	A18	B18	DRQ1
SA12	A19	B19	Refresh-
SA11	A20	B20	SYSClk
SA10	A21	B21	IRQ7
SA9	A22	B22	IRQ6
SA8	A23	B23	IRQ5
SA7	A24	B24	IRQ4
SA6	A25	B25	IRQ3
SA5	A26	B26	DACK2-
SA4	A27	B27	TC
SA3	A28	B28	BALE
SA2	A29	B29	+5V
SA1	A30	B30	OSC
SA0	A31	B31	Ground
Ground	A32	B32	Ground

Connector Type: J1 - 64 pins .435" high solder tails

J2 - 40 pins .435" high solder tails

6.1.2 PC-104 (J3)

The board contains a non-stack through / short pin PC-104 connector on the top side in the standard position as described by the PC/104-Plus specification.

J3				
Pin	A	B	C	D
1	GND/5.0V KEY ²	Reserved	+5	AD00
2	VI/O	AD02	AD01	+5V
3	AD05	GND	AD04	AD03
4	C/BE0*	AD07	GND	AD06
5	GND	AD09	AD08	GND
6	AD11	VI/O	AD10	M66EN
7	AD14	AD13	GND	AD12
8	+3.3V	C/BE1*	AD15	+3.3V
9	SERR*	GND	SB0*	PAR
10	GND	PERR*	+3.3V	SDONE
11	STOP*	+3.3V	LOCK*	GND
12	+3.3V	TRDY*	GND	DEVSEL*
13	FRAME*	GND	IRDY*	+3.3V
14	GND	AD16	+3.3V	C/BE2*
15	AD18	+3.3V	AD17	GND
16	AD21	AD20	GND	AD19
17	+3.3V	AD23	AD22	+3.3V
18	IDSEL0	GND	IDSEL1	IDSEL2
19	AD24	C/BE3*	VI/O	IDSEL3
20	GND	AD26	AD25	GND
21	AD29	+5V	AD28	AD27
22	+5V	AD30	GND	AD31
23	REQ0*	GND	REQ1*	VI/O
24	GND	REQ2*	+5V	GNT0*
25	GNT1*	VI/O	GNT2*	GND
26	+5V	CLK0	GND	CLK1
27	CLK2	+5V	CLK3	GND
28	GND	INTD*	+5V	RST*
29	+12V	INTA*	INTB*	INTC*
30	-12V	Reserved	Reserved	GND/3.3V KEY ²

Connector Type: 30 x 4 pin 2mm pitch with solder tails

6.1.3 LVDS LCD (J4)

J4 can be used to connect the LCD. Connector J4 provides access to the internal LVDS LCD display drivers. Note that the connector J20 can be used for LCD backlight properties. The LCD panel power is jumper-selectable for 3.3V (default) or 5V.

J4		
Ground	1 2	Ground
Power	3 4	Power
Power	5 6	Power
Power	7 8	NC
DID Clk	9 10	DID Data
D0- odd	11 12	D0- Even
D0+ Odd	13 14	D0+ Even
Ground	15 16	Ground
D1- Odd	17 18	D1- Even
D1+ Odd	19 20	D1+ Even
Ground	21 22	Ground
D2- Odd	23 24	D2- Even
D2+ Odd	25 26	D2+ Even
Ground	27 28	Ground
Clk- Odd	29 30	Clk- Even
Clk+ Odd	31 32	Clk+ Even
Ground	33 34	Ground
D3- Odd	35 36	D3- Even
D3+ Odd	37 38	D3+ Even
Ground	39 40	Ground

Signal	Definition
D0-3 +/- Even	Primary Data Channel, bits 0-2 (LVDS Differential signaling)
D0-3 +/- Odd	Primary Data Channel, Clock (LVDS Differential signaling)
CLK +/- Even	Secondary Data Channel, bits 0-2 (LVDS Differential signaling)
CLK +/- ODD	Secondary Data Channel, Clock (LVDS Differential signaling)
Power	+3.3V Switched Power Supply for LCD display (only powered up when LCD display is active)
Ground	Power Ground, 0V

Connector Number & Description: Samtec TFM-120-02-L-DH 2x20 position 1.27mm pitch right angle connector

Mating Connector: Housing: ISDF-20-D-M Crimp terminal: CC03R-2830-01-G

Note: The Display Port to LVDS Bridge PTN3460 from NXP is used to realize dual channel (ODD + EVEN) LVDS. For single channel displays, only ODD channel need to be used. Even channel should be left unconnected. PTN3460 can be configured to be in single channel using NXP's PTN3460 DPCD utility.

6.1.4 HDMI (J5)

Standard HDMI connector Type A right angle has been mounted on the board.

Note: If HDMI is used, Display Port will not be available and vice versa. Selection between HDMI and DP can be done from BIOS GUI.

J5			
Data 2+	1	2	Ground
Data 2-	3	4	Data 1+
Ground	5	6	Data 1-
Data 0+	7	8	Ground
Data 0-	9	10	Clock+
Ground	11	12	Clock-
CEC (NC)	13	14	Reserved
DDC Clock	15	16	DDC Data
Ground	17	18	+5V
Hot Plug Detect	19	20	NC

Connector Number & Description: FCI 10029449-001RLF HDMI standard type A right angle connector

6.1.5 Display Port (J6)

A standard Display port connector with the following pin-out has been used on the board.

Note: If HDMI is used, Display Port will not be available and vice versa. Selection between HDMI and DP can be done from BIOS GUI.

J6			
Lane 0+	1	2	Ground
Lane 0-	3	4	Lane 1+
Ground	5	6	Lane 1-
Lane 2+	7	8	Ground
Lane 2-	9	10	Lane 3+
Ground	11	12	Lane 3-
Ground	13	14	Ground
Aux+	15	16	Ground
Aux-	17	18	Hot Plug Detect
Power return	19	20	3.3V (fused)

Connector Number & Description: Molex 47272-0001 Display port standard right angle connector

6.1.6 USB 3.0 Ports (J7)

Connector J7 provides both USB 3.0 and USB 2.0 connections.

J7		
1	USB Power	
2	USB 2.0 Data-	USB 2.0 signals
3	USB 2.0 Data+	
4	Ground	
5	SSRX-	USB 3.0 signals
6	SSRX+	
7	Ground	
8	SSTX-	
9	SSTX+	

Connector Number & Description: FCI 10117835-002LF USB 3.0 standard Type A right angle connector

6.1.7 USB 2.0 Ports (J8)

Aries provides four USB 2.0 ports. Two of which are connected to the USB 2.0 header, whose pin-out has been provided below. Access to one of the remaining two is provided by a USB3.0 connector and the other through the PCIe MiniCard connector.

J8	
1	USB1 Power
2	USB1 Data-
3	USB1 Data+
4	Ground
5	Shield
6	USB2 Power
7	USB2 Data-
8	USB2 Data+
9	Ground
10	Shield

Connector Number & Description: JST SM10B-GHS-TBT 1x10 position 1.25mm pitch right angle connector

Mating Connector: Housing: GHR-10V-S Crimp terminal: SSHL-002T-P0.2

6.1.8 Serial ports (J9, J10)

Connector J9 and J10 provide 4 serial ports for RS-232/422/485 protocols, two ports per connector. Pin-out of both connectors is the same.

The following tables list the signal assignments on the pin header for each serial protocol.

RS-232		RS-422		RS-485		DB15 pin equivalent		
						RS-232	RS-422	RS-485
1	TX1	1	TX1-	1	TX/RX 1-	NC	NC	NC
2	RX1	2	RX1+	2	NC	RXD	RX+	
3	RTS1	3	TX1+	3	TX1/RX 1+	TXD	TX-	D-
4	CTS1	4	RX1-	4	NC	NC	NC	NC
5	Ground	5	Ground	5	Ground	GND	GND	GND
6	TX2	6	TX2-	6	TX/RX 2-	NC	NC	NC
7	RX2	7	RX2+	7	NC	RTS	TX+	D+
8	RTS2	8	TX2+	8	TX/RX 2+	CTS	RX-	
9	CTS2	9	RX2-	9	NC	NC	NC	NC
10	Ground	10	Ground	10	Ground	GND	GND	GND

Connector Number & Description: JST SM10B-GHS-TBT 1x10 position 1.25mm pitch right angle connector

Mating Connector: Housing: GHR-10V-S Crimp terminal: SSHL-002T-P0.2

6.1.9 External Battery (J11)

Connector J11 should be used to enable the use of an external battery.

J11	
1	Battery In
2	Ground

Connector Number & Description: Molex 22-05-7025 1x2 position 2.5mm pitch right angle connector

Mating Connector: Housing: 50-37-5023 Crimp terminal: 08-70-1040

Note: The RTC requires an external battery connection to maintain its functionality and it's RAM while the SoC is not powered by the system.

Example batteries are: Duracell* 2032, 2025, or 2016 (or equivalent), which can give many years of operation. Batteries are rated by storage capacity. The battery life can be calculated by dividing the capacity by the average current required. For example, if the battery storage capacity is 170 mAh (assumed usable) and the average current required is 6 μ A, the battery life will be at least: $170,000 \mu\text{Ah} / 6 \mu\text{A} = 28,333 \text{ h} = 3.2 \text{ years}$

The voltage of the battery can affect the RTC accuracy. In general, when the battery voltage decays, the RTC accuracy also decreases.

6.1.10 Input Power (J12)

Input power may be supplied through the connector J12 or through PC-104 and PC/104-Plus connectors, as the 5V supply is routed directly to the input power connector. All the required supply voltages for the board are derived from the 5V input. The +12V input is optional and necessary only to drive LCD backlight or other add-on features that require +12V.

J12

Ground	1	5	+12V (optional)
Ground	2	6	+5V
Ground	3	7	+5V
Ground	4	8	+5V

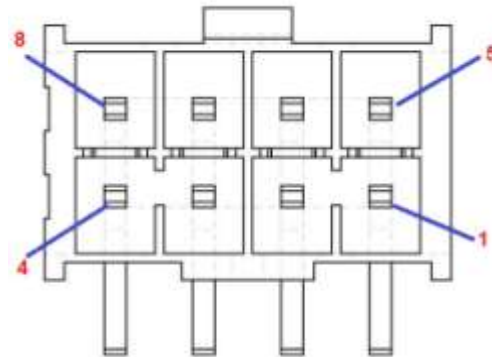

Front view of power connector

Connector Number & Description: Samtec ASP-194529 2x4 position 2.54mm pitch right angle connector

Mating Connector: Housing: IPD1-04-D-K Crimp terminal: CC79L-2024-01-L



Power Cable 6980512 (Front)



Power Cable 6980512 (Back)

6.1.11 Audio (J13)

Audio signals are made available on a latching connector J13.

J13

1	LineOut – L
2	LineOut – R
3	GND_Audio
4	LineIn – L
5	LineIn – R
6	GND_Audio
7	MIC IN
8	GND_Audio

Connector Number & Description: JST SM08B-GHA-TBT 1x8 position 1.25mm pitch right angle connector

Mating Connector: Housing: GHR-08V-S Crimp terminal: SSSL-002T-P0.2

Ethernet (J14)

Ethernet ports 1 and 2 are made available on the header J14 connected by two magnetics one per port.

J14			
Port 1 DA+	1	2	Port 2 DA+
Port 1 DA-	3	4	Port 2 DA-
Port 1 DB+	5	6	Port 2 DB+
Port 1 DB-	7	8	Port 2 DB-
Port 1 DC+	9	10	Port 2 DC+
Port 1 DC-	11	12	Port 2 DC-
Port 1 DD+	13	14	Port 2 DD+
Port 1 DD-	15	16	Port 2 DD-
Port 1 Shield	17	18	Port 2 Shield
N/C	19	20	N/C

Connector Number & Description: JST SM20B-GHDS-GAN-TF 2x10 position 1.25mm pitch right angle connector

Mating Connector: Housing: GHDR-20V-S(F) Crimp terminal: SGHD-002GA-P0.2

6.1.10 SATA (J15)

J15 can be used to connect an external SATA hard drive or an on-board SATA-DOM. Pin 7 is connected to a jumper that selects either ground or 5VDC system voltage rail. Ground is used for external storage device, and 5V is used for a board-mounted SATA flash-disk module.

J15	
1	Ground
2	SATA 1 TX+
3	SATA 1 TX-
4	Ground
5	SATA 1 RX-
6	SATA 1 RX+
7	Ground / 5V

Connector Number & Description: Molex 678005025 SATA standard vertical connector

6.1.14 Digital I/O (J16)

Aries provides three digital I/O ports with 8 lines on port A and B, and 6 lines on port C. Port A and B are provided on connector J16. Port C is on connector J17 and pin 18 of connector J16.

J16			
VIO (fused)	1	2	DIO A0
DIO A1	3	4	DIO A2
DIO A3	5	6	DIO A4
DIO A5	7	8	DIO A6
DIO A7	9	10	DIO B0
DIO B1	11	12	DIO B2
DIO B3	13	14	DIO B4
DIO B5	15	16	DIO B6
DIO B7	17	18	DIO C5
Ground	19	20	Ground

Connector Number & Description: JST SM20B-GHDS-GAN-TF 2x10 position 1.25mm pitch right angle connector

Mating Connector: Housing: GHDR-20V-S(F) Crimp terminal: SGHD-002GA-P0.2

6.1.15 Analog I/O (J17)

The VIO pins on the analog and digital I/O connectors are tied together on the board and provide access to jumper-selectable 3.3V / 5V system voltage rail through a poly-switch resettable fuse. The fuse is rated for ~100mA maximum sustained current.

J17			
Ain 0	1	2	Ain 8
Ain 1	3	4	Ain 9
Ain 2	5	6	Ain 10
Ain 3	7	8	Ain 11
Ain 4	9	10	Ain 12
Ain 5	11	12	Ain 13
Ain 6	13	14	Ain 14
Ain 7	15	16	Ain 15
Analog Ground	17	18	Analog Ground
Aout 0	19	20	Aout 1
Aout 2	21	22	Aout 3
Analog Ground	23	24	DIO C0
DIO C1	25	26	DIO C2
DIO C3	27	28	DIO C4
VIO (fused)	29	30	Digital Ground

Connector Number & Description: JST SM30B-ZPDSS-TF 2x15 position 1.5mm pitch right angle connector

Mating Connector: Housing: ZPDR-30V-S Crimp terminal: SZPD-002T-P0.3

6.1.16 Utility Connector (J18)

Status LED's of Ethernet ports are accessible from the utility connector J18. The 3.3V pin is connected to the system 3.3V rail through a poly-switch resettable fuse.

J18	
1	I2C Clock
2	I2C Data
3	Ground
4	Reset
5	Power Switch
6	Eth 1 Activity
7	Eth 1 Link 100
8	Eth 1 Link 1000
9	Eth 2 Activity
10	Eth 2 Link 100
11	Eth 2 Link 1000
12	+3.3V

Signal	Definition
Eth1/2 ACT	Activity LED
Eth1/2 Link 100	Link 100 LED
Eth1/2 Link 1000	Link 1000 LED
Power Switch	Power switch button
Reset	System reset button

The Aries SBC can be powered on by pressing the power switch when the board has been shut down. Also, the reset button can be used for a system reset. All the LEDs are active LOW.

Connector Number & Description: JST SM12B-GHS-TBT 1x12 position 1.25mm pitch right angle connector

Mating Connector: Housing: GHR-12V-S Crimp terminal: SSLH-002T-P0.2

6.1.17 VGA (J19)

Connector J19 is used for connecting a VGA monitor.

Pin	Signal	DB15 pin equivalent
1	Red	1
2	Gnd-Red	6
3	Green	2
4	Gnd-Green	7
5	Blue	3
6	Gnd-Blue	8
7	HSync	13
8	VSync	14
9	Gnd-Sync	10
10	DDC-Data	12
11	DDC-Clock	15
12	Ground	5

Signal	Definition
Ground	Ground return
Red	RED signal
Green	GREEN signal
Blue	BLUE signal
DDC clock/data	Digital serial I/O signals used for monitor detection (DDC1 specification)
HSYNC	Horizontal sync
VSYNC	Vertical sync

Connector Number & Description: JST SM12B-GHS-TBT 1x12 position 1.25mm pitch right angle connector

Mating Connector: Housing: GHR-12V-S Crimp terminal: SSHL-002T-P0.2

6.1.18 LCD Backlight (J20)

Connector J20 can be used for the LCD backlight. Input power source is user selectable using jumpers to 5V or 12V.

J20	
1	Power, +5V/+12V, jumper selectable
2	Power, +5V/+12V, jumper selectable
3	Ground
4	Ground
5	Backlight Enable (GPIO output), 0 = off, open circuit = on
6	Brightness control

Brightness may be controlled over pin 6 on this connector.

Connector Number & Description: Molex 053261-0671 1x6position 1.25mm pitch right angle connector

Mating Connector: Housing: 51021-0600 Crimp terminal: 50058-8000

6.1.19 mSATA / PCIe MiniCard Socket (J21)

This socket can be used for both PCIe MiniCard and mSATA disk module use. The configuration is selected with a switch that is controlled by pin 7. A PCIe MiniCard will tie pin 7 to ground, while an mSATA module will leave pin 7 open. Pin 7 has a pull-up resistor on the board. All TX/RX signals are with respect to the host. TX on the socket drives RX on the installed module, and RX on the socket is driven by TX on the installed module.

The two mounting standoffs at the far end of the module installation site are not connected to ground.

PCIe Mini Card	mSATA	J21	mSATA / PCIe MiniCard
		1	+3.3V
		2	
		3	Gnd
		4	
		5	+1.5V
		6	
Clkreq-		7	
Gnd	Gnd	8	
		9	
PCIe 1 Clk-	PCIe 1 Clk- *	10	
PCIe 1 Clk+	PCIe 1 Clk+ *	11	
Gnd	Gnd	12	
		13	
		14	
		15	
		16	
		KEY	
		17	Gnd
		18	
		19	Disable-
		20	PCIe Reset-
Gnd	Gnd	21	+3.3V
PCIe 1 RX-	SATA 0 TX+	22	Gnd
PCIe 1 RX+	SATA 0 TX-	23	+1.5V
Gnd	Gnd	24	SMB Clk
Gnd	Gnd	25	SMB Data
PCIe 1 TX-	SATA 0 RX-	26	Gnd
PCIe 1 TX+	SATA 0 RX+	27	
Gnd	Gnd	28	
Gnd	Gnd	29	
+3.3V	+3.3V	30	
+3.3V	+3.3V	31	
Ground	Ground	32	
		33	
		34	
		35	
		36	
		37	
		38	
		39	Gnd
		40	WWAN LED-
		41	WLAN LED-
		42	WPAN LED-
		43	+1.5V
		44	
		45	
		46	
		47	+1.5V
		48	
Pull-up to +3.3V	Pull-up to +3.3V	49	Gnd
		50	+3.3V
		51	
		52	

* For mSATA mode, the PCIe clock signal is not active because CLKREQ- pin is not driven low by the module.

Connector Type: 52-pin MiniCard, full size, with PCB mount threaded spacers

6.2 List of Connectors

The following table provides a summary of all I/O connectors on the board and their corresponding Diamond Systems cables where appropriate. Connectors on the top side are mostly vertical, and connectors on the bottom side are always right-angle

Ref Designator	Function	Manufacturer	Part Number	Description	Cable part numbers
J1	PC/104	Harwin*	M20-6113245*	64 pins .435" high solder tails	
J2	PC/104	Harwin*	M20-6112045*	40 pins .435" high solder tails	
J3	PC/104-Plus	Aptos*	PQE-C0-VB-094/023-FG*	30 x 4 pin 2mm pitch with solder tails	
J4	LCD	Samtec	TFM-120-02-L-DH-WT	40 pos .050" pitch dual row right angle latching	
J5	HDMI	Generic	Generic	Standard HDMI type A connector, right angle	
J6	DisplayPort	Generic	Generic	Standard Display Port connector, right angle	
J7	USB 3.0 / 2.0	FCI*	10117835-002LF	USB 3.0 type A receptacle, right angle	
J8	USB 2.0	JST	SM10B-GHS-TBT	10 pos. 1.25mm pitch right angle latching	6980503
J9, J10	Serial ports (qty 2)	JST	SM10B-GHS-TBT	10 pos. 1.25mm pitch right angle latching	6980500
J11	External battery	Molex	22-05-7025	2 pos. 2.5mm pitch right angle	6980524
J12	Power in	Samtec	IPL1-104-01-L-D-RA-K	2x4 box header T/H right angle .1" pitch	6980512
J13	Audio	JST	SM08B-GHS-TBT	8 pos. 1.25mm pitch right angle latching	6980508
J14	Ethernet	JST	SM20B-GHDS-GAN-TF	20 pos. 1.25mm pitch right angle latching	6980513
J15	SATA	Generic	Generic	7-pin SATA connector, vertical	6989101
J16	DAQ digital I/O	JST	SM20B-GHDS-GAN-TF	Cable, GHDR-20V-S to DB-37F	6980517
J17	DAQ analog I/O	JST	SM30B-ZPDSS-TF	Cable, ZPDR-30V-S to DB-37F	6981518
J18	Utility	JST	SM10B-GHS-TBT	10 pos. 1.25mm pitch right angle latching	6980514
J19	VGA	JST	SM12B-GHS-TBT	12 pos. 1.25mm pitch right angle latching	6980507
J20	LCD backlight	Molex	053261-0671	6 pos. 1.25mm pitch right angle	
J21	PCIe Mini Card	JAE	MM60-52B1-E1-R650 + NT4R1600 spacer	52-pin MiniCard, full size, with PCB mount threaded spacers	

* Representative part; other manufacturers / part numbers are also acceptable.

7. JUMPER DESCRIPTION

Following drawing shows only the connectors and jumper blocks on the board. The default jumpers of the jumper blocks are shown in red.

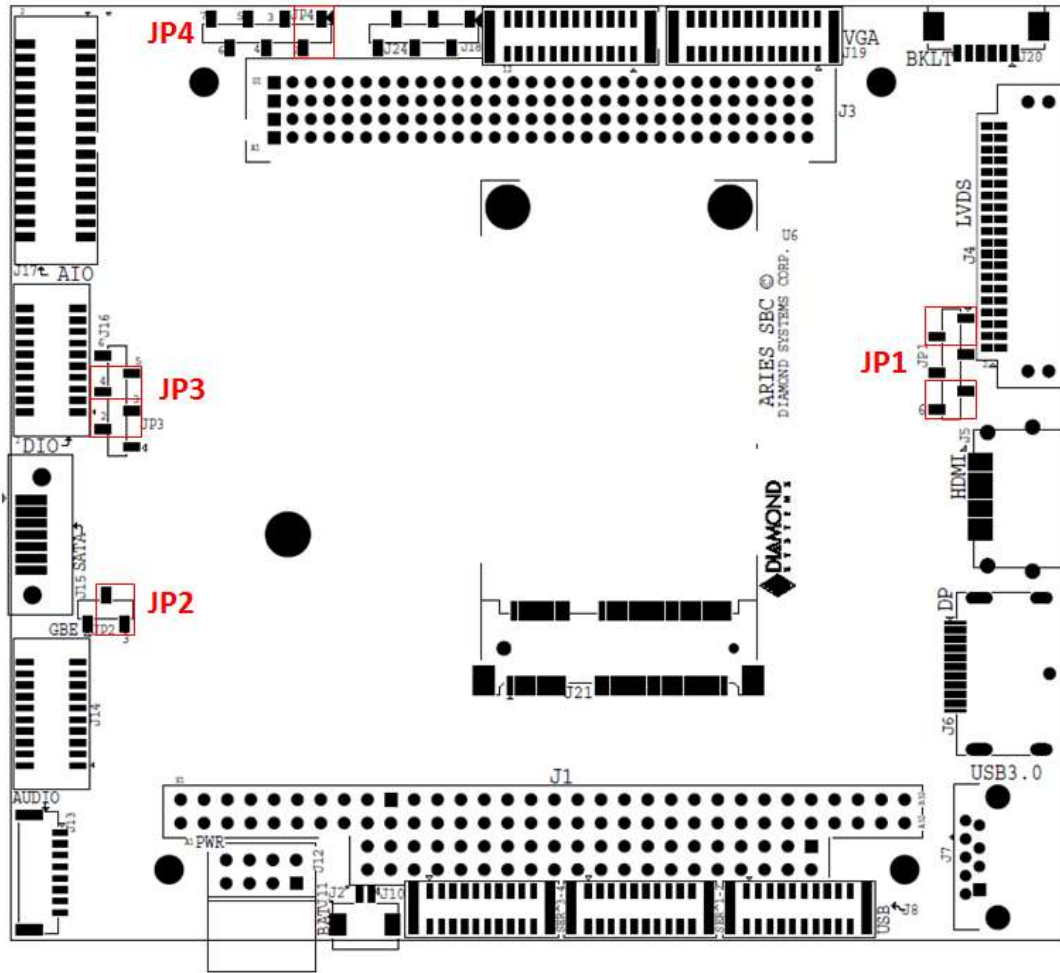

Figure 4: Default Jumper locations

<i>Jumper</i>	<i>Description</i>
JP1	LVDS VDD & Backlight
JP2	SATA DOM
JP3	Digital VIO
JP4	PCI voltage selection and FPGA base address

7.1 LVDS Backlight and LVDS VDD (JP1)

Jumper block JP1 configures the voltage supply for the LCD backlight and for LVDS VDD as well. The orientation of the block in the diagrams matches the orientation of the jumper block when the board is rotated so that the PC/104 connector is on the lower edge.

Available options are +5V and +12V from the main power supply input. +12V is not used by any circuit on the Aries. +12V is needed for the LCD backlight, and the backlight is to be powered via the backlight power connector J9, hence +12V is supplied on the main power input connector along with +5V.

By default LVDS backlight is provided with +12V and the LVDS VDD is provided with 3.3V. Figure 5 shows the default jumper locations.

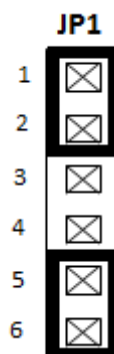

Figure 5: Jumper Block JP1

The following table shows different combinations of jumper locations on JP1.

1-2	2-3	4-5	5-6	LVDS Backlight	LVDS VDD
In	Out	In	Out	12V	5V
<i>In</i>	<i>Out</i>	<i>Out</i>	<i>In</i>	<i>12V</i>	<i>3.3V</i>
Out	In	In	Out	5V	5V
Out	In	Out	In	5V	3.3V

Note:

1. Voltage supply on LVDS backlight will not depend on or affect the voltage input of LVDS.
2. Do not install a jumper on 3-4 positions.

7.2 SATA (JP2)

The 7th pin of the SATA connector J15 can be configured for SATA DOM or for SATA cable. By default 7th pin of J15 is connected to ground for the SATA cable. The default jumper location is shown in Figure 6.

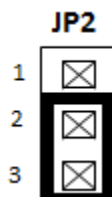

Figure 6: Jumper Block JP2

The following table shows the combination of jumper block JP2. The row in bold and italics shows the default configuration.

1-2	2-3	Description
<i>Out</i>	<i>In</i>	SATA_PIN7 = GND (SATA CABLE)
In	Out	SATA_PIN7 = 5.0V (SATA DOM)

7.3 Digital IO (JP3)

The digital I/O can be pulled up to 5V/3.3V or pulled down to GND by configuring jumper block JP3. The jumper locations of this jumper block will also determine the power input to the DIO transceiver.

By default the DIO's are pulled high to 3.3V. Figure 7 shows the default jumper locations of JP3.

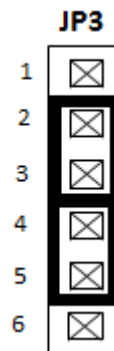

Figure 7: Jumper Block JP3

The following table shows the different combinations of jumper block JP3. The row in bold and italics shows the default configuration of jumper block JP3.

1-2	2-3	4-5	5-6	DIO pull high/low	DIO Voltage
In	Out	In	Out	Low	3.3V
In	Out	Out	In	Low	5V
<i>Out</i>	<i>In</i>	<i>In</i>	<i>Out</i>	<i>High</i>	<i>3.3V</i>
Out	In	Out	In	High	5V

Note:

- Jumpers should be installed in either positions 4-5 or 5-6 even if the jumper in position 1-2 is Out (DIO are pulled Low to GND) as this voltage powers the DIO transceivers.

7.4 Miscellaneous (JP4)

Jumper block JP4 can be used to select the PCI voltage and configure the FPGA base address. The following information describes how to set these various options.

PCI Voltage Selection

The PCI voltage can be set for either 3.3V or 5V with pins 1, 2 and 3 of JP4 as follows:

<u>Jumper on Pins</u>	<u>PCI voltage</u>
1 & 2	3.3V (default)
2 & 3	5V

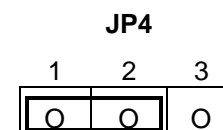

FPGA Base Address Selection

The base address of Aries' FPGA can be set for either 0x280 or 0x240 with pins 4 and 5 of JP4 as follows:

<u>Pins 4 & 5</u>	<u>FPGA Base Address</u>
No jumper	0x280 (default)
Jumper	0x240

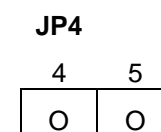

Note: Jumper block JP4 pins 6/7 and 8/9 are for factory use only. A jumper should never be applied to these pins.

8. BIOS KEY FEATURES

The BIOS on Aries provides access to many valuable features. These instructions show how to enter the BIOS and set up features.

8.1 Entering the BIOS

The BIOS may be entered during startup by pressing the **DEL** key on an attached keyboard or pressing **ESC**. Press the key repeatedly right after power-on or reset until the BIOS screen appears.

After a certain amount of time during startup, the BIOS will ignore the DEL or ESC key. If the user waits too long and the system does not respond, then the user can simply reset the board (or power down) and try again.

8.2 Restoring Default BIOS Settings

When the user makes changes to the BIOS settings, the new settings are stored in SPI flash. If the user wants to restore the BIOS settings to their defaults, it can be done by using the following procedure.

1. Connect a keyboard to the USB keyboard port and connect a monitor.
2. Reboot the CPU (reset or power-down and power-up).
3. Hold down the HOME/END key while the CPU is booting.
4. The board will boot up normally. The BIOS settings will be reset to their defaults.

8.3 Setting the Date and Time

The date and time are set in the BIOS. Select **Main** menu, then enter the date and time at the bottom of the screen. This screen also displays the CPU speed and memory capacity of the board.

8.4 Boot Priority

To select Boot devices and priority, go to the **Boot** menu and select **Boot Device Priority**. Only devices which are connected to the board will appear in the list of options. Therefore if the user wants to select a hard drive or USB device as the boot device, CPU should be connected first, then boot up and enter the BIOS, then select it as a boot device. If this menu option does not appear on the screen, it means that the on-board flash drive is not enabled, and either no boot devices are attached or the CPU does not recognize any attached boot devices.

8.5 Setting Usable Memory

A standard 32-bit operating system has a maximum addressable memory range of 4GB. Of this, 1GB is reserved for the PCI bus by the processor. Therefore a maximum of 3GB memory is free for use with the 32-bit operating system due to the maximum TOLUD (Top of Low Usable DRAM Register) of 3GB. This is commonly referred to as the 3GB barrier. A 64-bit Windows operating system can map the entire 4GB memory range.

For users who prefer using a 32-bit OS over a 64-bit OS, they should use a kernel that supports Physical Address Extension (PAE) to access the entire 4GB of memory. Linux kernels support PAE as a build option.

If a 32-bit OS is only seeing 2GB and not 3GB of memory when 4GB is installed, change the BIOS setup option for system memory from 2G to 3G by going to:

Chipset → North Bridge → Max TOLUD [3G]

Press F4 to Save and Exit.

Check the useable system memory in the System Properties window or Task Manager window to confirm the system memory is now set at 2.89GB (3GB).

For customers who need or want to use more than 3GB of system memory, they should use a 64-bit Windows operating system version or implement a 32-bit OS with PAE.

8.6 LED

A green BIOS LED has been provided to indicate that the board has been booted to BIOS GUI. The location of the BIOS LED is shown in the Board Layout Section.

8.7 Quiet / Quick Boot / Splash Screen

Quiet boot replaces the system status and configuration screen that appears during startup with a blank screen or custom splash screen (if available). Quick boot turns off memory test during startup to save time. To enable these features, go to the **Boot** menu, then select **Boot Settings Configuration**. Diamond can provide custom splash screens upon request from an image file.

8.8 Selecting the Displays

Aries SBC supports two independent displays at a given time. Any two of the following displays can be selected from BIOS GUI:

- VGA
- LVDS
- DP or HDMI

8.9 Serial Port Configuration

Aries SBC provides four serial ports. Each of these ports can be individually configured as RS-232/422/485 from the BIOS GUI. To configure the serial ports, the user must first specify the target operating system as follows:

In BIOS Setup

go to Advanced

then Miscellaneous Control
select the target operating system under OS Selection

Once this selection is done, the serial port configuration can be made.

9. GETTING STARTED

This section describes the steps needed to get Aries SBC up and running, and assumes that user also has a Aries Development Kit or Aries Cable Kit. The Cable Kit includes all cables needed for the I/O, except the LCD and backlight. The Development Kit includes the Cable Kit, an AC adapter to power the board, an SATA hard drive, and the hard drive programmer board.

9.1 Development Kit

<i>Model Number</i>	<i>Description</i>
ARS3845-4GA	Aries SBC, 1.91GHz E3845 CPU, 4GB DRAM, data acquisition
CK-ARS-03	Aries Cable Kit
	32GB MLC SATA-DOM flash-disk with bootable Linux image
	Aries Development Kit manual

9.2 Quick Setup

1. Attach VGA cable 6980507, USB keyboard / mouse cable and USB cables 6980503 as needed.
2. Attach display, keyboard, and mouse (if needed) to the cables.
3. Connect the jumpers as mentioned in Section 7 for a default settings or can be changed as desired by the user.
4. Attach the hard disk with cable or install hard drive with bootable OS or DSC provided BSP
5. Connect power to power input connector J12 using AC adapter or personal power supply with power cable 6980512. The input connector and cable are keyed to prevent incorrect connection.

The input voltage for Aries is 5V. The current drawn by the board for this configuration would be approximately. 1A.

WARNING: Attaching the power connector may damage the Aries SBC!

5. On powering up and continuously pressing the DEL/ESC key will lead the board to boot the BIOS GUI.

9.3 Boot Device Options

Aries can boot from SATA, mSATA, any of the four USB ports or PXE. Either a board powered SATA DOM or an externally powered SATA HDD can be connected to the SATA port. DSC will provide a flash-disk (SATA DOM or mSATA) with pre-loaded OS.

Aries can boot to an SATA device or a USB device. SATA supports mSATA and SATA DOM. Aries can be booted from the flash-disk provided by DSC or from an external blank drive.

WARNING: It is possible to destroy the Aries SBC by connecting a SATA cable incorrectly (reverse orientation or offset from correct position). Always use keyed cables to avoid connection errors.

The Boot device selection and priority are configured in the BIOS **Boot** menu. Only devices which are connected to the SBC will appear in the list of options. Therefore if user wants to select a hard drive or USB device as the boot device, the SBC should be connected first, then boot up and enter the BIOS, then select it as a boot device.

The following are a few example boot scenarios.

- ◆ Install an externally powered SATA hard drive directly on the SATA connector.
- ◆ Attach a SATA DOM on the SATA connector (the Aries SBC will provide power to the SATA DOM over Jumper JP2 1-2)
- ◆ Attach an mSATA device on the Mini PCIe socket
- ◆ Attach a bootable USB device to one of the USB ports.
- ◆ PXE boot
- ◆ If no bootable device is attached to the Aries SBC, the system will boot to EFI shell.

10. DATA ACQUISITION CIRCUIT

10.1 Overview

Aries contains a data acquisition subsystem consisting of A/D, D/A, digital I/O, and counter/timer features.

The A/D section includes a 16-bit A/D converter, 16 analog input channels and a 2048-sample FIFO. Input ranges are programmable, and the maximum sampling rate is 250 KHz. The D/A section include 4 16-bit D/A channels. The digital I/O section includes up to 22 lines with programmable direction. The counter/timer section includes 32-bit counter/timer to control A/D and a 32-bit counter/timer for user applications.

High-speed A/D sampling is supported with interrupts and a FIFO. The FIFO is used to store up to 2048 A/D samples. An interrupt occurs when the FIFO reaches a user-selected threshold. Once the interrupt occurs, an interrupt routine runs and reads the data out of the FIFO. In this way the interrupt rate is reduced by a factor equal to the size of the FIFO threshold, enabling a faster A/D sampling rate and lower software overhead.

The A/D circuit uses the default settings of I/O address range 0x240 – 0x280 (base address 0x240). These settings can be changed if needed. The I/O address range is changed in the BIOS.

The figure below shows the overview of the data acquisition circuit.

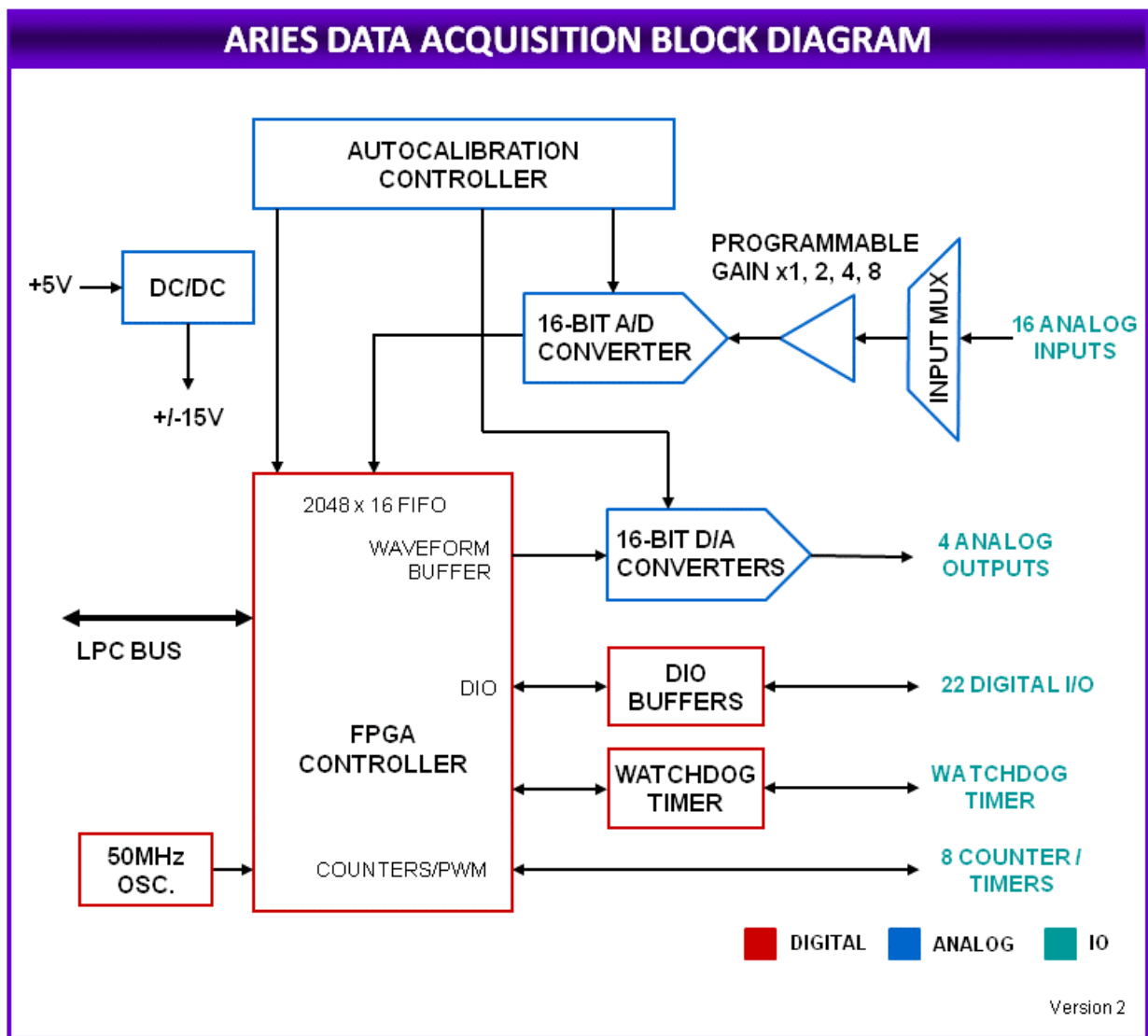

Figure 9: Data Acquisition Circuit Block Diagram

10.2 FPGA

The FPGA provides all of the logic functions of the Aries SBC data acquisition as well as a watchdog timer and a power sequencing circuit. The chip also interfaces to a Renesas encryption chip for future security features.

The following table shows a list of all the features offered by Aries FPGA.

Feature	Description
A/D channels	16 16-bit Analog inputs
D/A channels	4 16-bit analog outputs
DIO Lines	22 lines: 1 8-bit port, 14 1-bit ports
Counter/Timers	8 32-bit
PWM	4 24-bit
Watchdog timer	2 Down counters Counter A - 16-bits Counter B - 8-bits

10.3 Bus Interface

Aries uses LPC for bus interface. LPC lines LAD[3:0] communicate address, control, and data information over the LPC between a host a peripheral. The information communicated is start, stop (abort a cycle), transfer type (memory I/O), transfer direction (Read/Write), address, data, wait states and bus master grant. Not all cycle types use the LAD bus in the same fashion.

Following are the different LPC pins used in the FPGA for communicating between a host and the peripheral.

- LPC_FRAME# - Indicates start of a new cycle, termination of broken cycle.
- LPC_RESET# - Same as PCI Reset on the host.
- LPC_CLK - Buffered 33MHz clock from the host. Input to the FPGA.
- LPC_SERIRQ - Serialized IRQ signal

10.4 Interrupts

The FPGA supports LPC interrupts from the analog input circuit, D/A fault indicator, digital I/O, and two counter/timers. Register bits ADINTEN, FINTEN, DINTEN, T2INTEN, and T3INTEN enable/disable interrupts. When an INTEN bit is 1, interrupts for that circuit are enabled. However, 0 disables the interrupt feature. The LPC bus interrupt level is selected with register bits IRQ3-0.

When a circuit is requesting interrupt service, its corresponding status bit DINT, ADINT, T2INT, or T3INT is high. Command bits DINTCLR, ADINTCLR, T2INTCLR, and T3INTCLR reset the associated interrupt request and status bit. In contrast to other command registers in this design, any or all of these command bits may be set simultaneously to clear multiple interrupt requests simultaneously.

ADINT=1 and an interrupt occurs when ADINTEN=1 and one of the following occurs:

FIFOEN	SCANEN	Action
0	0	Interrupt occurs after each A/D conversion completes (ADBUSY goes low).
0	1	Interrupt occurs after each A/D scan completes (ADBUSY goes low).
1	0	Interrupt occurs when A/D conversion completes and FIFO threshold is reached or exceeded .
1	1	Interrupt occurs when A/D scan completes and FIFO threshold is reached or exceeded.

T2INT=1 and an interrupt occurs when T2INTEN=1 and counter/timer 2 counts down to 0. There is no terminal count and therefore no interrupt source when counter/timer 2 is counting up.

T3INT=1 and an interrupt occurs when T3INTEN=1 and counter/timer 3 counts down to 0. There is no terminal count and therefore no interrupt source when counter/timer 3 is counting up.

DINTSEL4-0 selects the digital I/O line to be used for edge-triggered interrupts. The selection is as follows:

0-7	Port A 0-7
8-15	Port B 0-7
16-21	Port C 0-5

When DINTEN = 1 and the digital I/O line specified by DINTSEL4-0 exhibits the edge specified by DINTEDGE, DINT = 1 and an interrupt occurs. DINTEDGE = 1 means rising edge, and 0 means falling edge. If the specified DIO line is in output mode, then writing to that line's output register with the correct transition will trigger the interrupt. When DINTCLR command is issued, the edge detect circuit will reset to be ready for the next edge. Setting DINTEN = 0 also resets the edge detect circuit, so that when DINTEN is set to 1 the circuit is ready for the first edge.

When register bit FINTEN = 1, a falling edge on DAC_FAULT# will generate an interrupt and set register bit FINT = 1. The interrupt request is cleared, and FINT = 0, by writing a 1 to command bit FINTCLR or generating a reset. The interrupt routine is responsible for clearing the fault condition on the AD5755 to cause the fault pin to reset to 1.

11. A/D CIRCUIT

11.1 A/D Input Ranges and Resolution

Aries uses a 16-bit A/D converter. This means that the analog input voltage can be measured to the precision of a 16-bit binary number. The maximum value of a 16-bit binary number is $2^{16} - 1$, so the full range of numerical values that user can get from Aries input channel is 0 - 65535.

The smallest change in input voltage that can be detected is $1/(2^{16})$, or $1/65536$, of the full-scale input range. This smallest change results in an increase or decrease of one in the A/D code, and is referred to as one Least Significant Bit (1 LSB).

11.2 Unipolar and Bipolar Inputs

Aries can measure both unipolar (positive only) and bipolar (positive and negative) analog voltages. The full-scale input voltage range depends on the Gain, Range, and Polarity bit settings in the Analog Configuration register (Base+11). In front of the A/D converter is a programmable gain amplifier that multiplies the input signal before it reaches the A/D. This gain circuit has the effect of scaling the input voltage range to match the A/D converter for better resolution. In general, the user should select the highest gain possible that will allow the A/D converter to read the full range of voltages over which the input signals varies. If the gain is too high, the A/D converter clips at either the high end or low end, and the user will be unable to read the full range of voltages on the desired input signals.

11.3 Ranges and Resolutions

The table below lists the full-scale input range for each valid analog input configuration. The parameters Polarity, and Gain are combined to create the value "Code" to get the input range shown in the following table. These registers are made available on the Base+4 address. A total of nine different input ranges are possible. The range programming codes 4, 5, 6, and 7 are invalid and that range codes 9–11 are equivalent to range codes 0–2.

Polarity	Range	Gain	Code	Input Range	Resolution (1 LSB)
Bipolar	5V	1	0	□ 5V	153□V
Bipolar	5V	2	1	□ 2.5V	76□V
Bipolar	5V	4	2	□ 1.25V	38□V
Unipolar	5V	1	4		Invalid Setting
Unipolar	5V	2	5		Invalid Setting
Unipolar	5V	4	6		Invalid Setting
Unipolar	5V	8	7		Invalid Setting
Bipolar	10V	1	8	□ 10V	305□V
Bipolar	10V	2	9	□ 5V	153□V
Bipolar	10V	4	10	□ 2.5V	76□V
Bipolar	10V	8	11	□ 1.25V	38□V
Unipolar	10V	1	12	0-10V	153□V
Unipolar	10V	2	13	0-5V	76□V
Unipolar	10V	4	14	0-2.5V	38□V

11.3.1 Conversion Formulas

The 16-bit value returned by the A/D converter is always a two's complement number ranging from -32768 to 32767, regardless of the input range. This is because the input range of the A/D is fixed at $\pm 10V$. The input signal is actually magnified and shifted to match this range before it reaches the A/D. For example, for an input range of 0–10V, the signal is first shifted down by 5V to $\pm 5V$ and then amplified by two to become $\pm 10V$. Therefore, two different formulas are needed to convert the A/D value back to a voltage, one for bipolar ranges, and one for unipolar ranges.

To convert the A/D value to the corresponding input voltage, use the following formulas, depending on bipolar or unipolar mode of operation.

11.3.1.1 CONVERSION FORMULA FOR BIPOLAR INPUT RANGES

$$\text{Input voltage} = \text{A/D code} / 32768 * \text{Full-scale input range}$$

Example:

Given, Input range is $\pm 5V$ and A/D code is 17761.

Therefore,

$$\text{Input voltage} = 17761 / 32768 * 5V = 2.710V.$$

For a bipolar input range,

$$1 \text{ LSB} = 1/32768 * \text{Full-scale voltage}.$$

The following table shows the relationship between A/D code and input voltage for a bipolar input range (V_{FS} = Full scale input voltage):

A/D Code	Input Voltage Symbolic Formula	Input Voltage for $\pm 5V$ Range
-32768	$-V_{FS}$	-5.0000V
-32767	$-V_{FS} + 1 \text{ LSB}$	-4.9998V
...
-1	-1 LSB	-0.00015V
0	0	0.0000V
1	+1 LSB	0.00015V
...
32767	$V_{FS} - 1 \text{ LSB}$	4.9998V

11.3.1.2 CONVERSION FORMULA FOR UNIPOLAR INPUT RANGES

$$\text{Input voltage} = (\text{A/D code} + 32768) / 65536 * \text{Full-scale input range}$$

Example:

Given, Input range is 0–10V and A/D code is 17761.

Therefore,

$$\text{Input voltage} = (17761 + 32768) / 65536 * 10V = 7.7103V.$$

For a unipolar input range, 1 LSB = 1/65536 * Full-scale voltage.

The table on the following illustrates the relationship between A/D code and input voltage for a unipolar input range (V_{FS} = Full scale input voltage).

A/D Code	Input Voltage Symbolic Formula	Input Voltage for 0-5V Range
-32768	0V	0.0000V
-32767	1 LSB ($V_{FS} / 65536$)	0.153 mV
...
-1	$V_{FS} / 2 - 1 \text{ LSB}$	4.99985V
0	$V_{FS} / 2$	5.0000V
1	$V_{FS} / 2 + 1 \text{ LSB}$	5.00015V
...
32767	$V_{FS} - 1 \text{ LSB}$	9.9998V

11.4 A/D Sampling Methods

11.4.1 FIFO Description

Aries uses a 2048-sample FIFO (First In First Out) memory buffer to manage A/D conversion data. The FIFO is used to store A/D data between the time it is generated by the A/D converter and the time it is read by the user program. In enhanced mode, the entire 2048-sample FIFO is available. In normal mode only 1024 samples are available. The FIFO may be enabled and disabled under software control.

In single-conversion mode, the FIFO features are not generally needed so FIFO use should not be selected (although the FIFO is actually being used). Each A/D sample is stored in the FIFO. When the software reads the data, it reads it out of the FIFO. In low-speed sampling, each time a conversion occurs, the program reads the data, so there is always a one-to-one correspondence between sampling and reading. Thus, the FIFO contents never exceed one sample.

For high-speed sampling or interrupt operation, the FIFO significantly reduces the amount of software overhead in responding to A/D conversions. Using the FIFO also reduces the interrupt rate on the bus because it enables the program to read multiple samples at a time. In addition, the FIFO is required for sampling rates in excess of the maximum interrupt rate possible on the bus. Generally, the fastest sustainable interrupt rate on the ISA bus running DOS is around 40,000 per second. Since Aries can sample up to 250,000 times per second, the FIFO is needed to reduce the interrupt rate at high speeds. When the interrupt routine runs, it reads multiple samples from the FIFO. The interrupt rate is equal to the sample rate divided by the number of samples read each interrupt. On Aries, this number is programmable using the FIFO Threshold register (Base+6). The usual value is 1/2 the maximum FIFO depth, or 1024 samples. Therefore, the maximum interrupt rate for Aries is reduced to 996 per second, which is easily sustainable on any popular operating system.

Note: If both scan and FIFO operations are enabled, the interrupt occurs at the programmed FIFO threshold and the interrupt routine reads the indicated number or samples and then exits. This happens even if the number of samples is not an integral number of scans. For example, if the user has a scan size of 10 and a FIFO threshold of 256, the first time the interrupt routine runs, it reads 256 samples, consisting of 25 full scans of all 10 channels followed by 6 samples from the next scan. The next time the interrupt routine runs, it reads the next 256 samples, consisting of the remaining 4 samples from the last scan it started to read, the next 25 full scans of 10 samples, and the first 2 samples of the next scan. (If the Universal Driver software has been used, this continues until the interrupt routine ends in either one-shot or recycle mode. In one-shot mode, the last time the interrupt routine runs it reads the entire contents of the FIFO, making all data available.)

11.4.2 Scan Sampling

A scan is defined as a quick burst of samples of multiple consecutive channels. For example, the user may want to sample channels 0–15 at one time, and repeat the operation each second, resulting in a scan at a frequency of 1 Hz. Each time the A/D clock occurs (software command, timer, or external trigger), all 16 channels are sampled in high-speed succession. There is a short delay of 4–20 microseconds between each sample in the scan. Since each clock pulse causes all channels to be sampled, the effective sampling rate for each channel is the same as the programmed rate, and the total sampling rate is the programmed sampling rate times the number of channels in the scan range.

Scan sampling is independent of FIFO operation, and can be enabled independently.

11.4.3 Sequential Sampling

In sequential sampling, each clock pulse results in a single A/D conversion on the current channel. If the channel range is set to a single channel (high channel = low channel), each conversion is performed on the same input channel. If the channel range is set to more than one channel (high channel > low channel), then the channel counter increments to the next channel in the range, and the next conversion is performed on that channel. When a conversion is performed on the high channel, the channel counter resets to the low channel for the next conversion. The intervals between all samples are equal. Since each clock pulse results in only one channel being sampled, the effective sampling rate is the programmed sampling rate divided by the number of channels in the channel range.

11.4.4 Sampling Methods

There are several different A/D sampling modes available on Aries board. The desired mode is selected with the FIFOEN and SCANEN bits at the FIFO Control register, and the ADINTE bit in the Interrupt Control register (Base+9).

Note: If interrupts are not enabled, the FIFO should not be enabled. FIFO storage is only useful when interrupts are used. Otherwise, the FIFO has no effect.

All of these features may be selected as arguments to function calls in the driver software. The control register details are provided for completeness and for programmers not using the driver.

SCANEN	FIFOEN	ADINTE	Mode	Description
No	No	No	Single Conversions	The most basic sampling method. Used for low-speed sampling (typically up to about 100 Hz) under software control where a precise rate is not required, or under external control where the rate is slow. Consists of either one channel or multiple channels sampled one at a time.
Yes	No	No	Scan Conversions	Used to sample a group of consecutively numbered channels in rapid succession, under software or external control. The time between samples in a scan is programmable between 5 to 20 microseconds, while the time between scans depends on the software or external trigger and may be very short or very long, but is usually less than about 100 Hz (above this rate use interrupt scans below).

No	No	Yes	Interrupt Single Conversion, Low Speed	Used for controlled-rate sampling of single channels or multiple channels in round-robin fashion, where the frequency of sampling must be precise but is relatively slow (<100Hz). The sampling clock comes from the on-board counter/timer or from an external signal. The interval between all A/D samples is identical.
Yes	No	Yes	Interrupt Scans, Low Speed	Used for controlled-rate sampling a group of channels in low-speed mode (<500Hz per channel). Each sampling event consists of a group of channels sampled in rapid succession. The time between scans is determined by the sample rate.
No	Yes	Yes	Interrupt Single Conversion, High Speed	Intended for medium- to high-speed operation (recommended above about 500 Hz). Can support sampling rates up to the board's maximum of 250,000 Hz. May also be used at slower rates if desired. The sampling clock comes from the on-board counter/timer or from an external signal.
Yes	Yes	Yes	Interrupt Scan Conversions	Used for high-speed sampling of a group of channels where the scan rate is high. The sampling clock comes from the on-board counter/timer or from an external signal.

12. D/A CIRCUIT

Aries utilizes the Analog Devices AD5755 D/A converter for all analog output functions. The AD5755 provides 4 16-bit DACs with high accuracy, low drift, programmable voltage and current output ranges, and digital calibration. Up to 4 of these devices may be installed on the board depending on the model. A precision, low-drift 5V voltage reference circuit provides the basis for the overall accuracy of the analog outputs.

The AD5755 contains an integrated digital calibration circuit consisting of a multiplier and adder. Each time data is written to a DAC, it undergoes a multiplication / addition operation, and the result is then transferred to the DAC channel. This operation takes about 5 microseconds to complete. Thus each write to a DAC channel results in a 5 us delay before the output begins to update to the new value. The total settling time for one channel consists of the settling time for the DAC plus this calibration time.

12.1 Ranges and Resolutions

12.1.1 Ranges

The chips provide voltage outputs in multiple output ranges. Each channel on each chip can be set to a different output range. Each channel has a voltage output pin and a ground return pin. The application wiring must connect to the voltage output pin or the current output pin, as needed.

A D/A converter converts a number, or output code, into an output voltage or current that is proportional to the number. The output range is the range of possible output values, from the smallest (lowest) value up to the highest (largest) value. The difference between the highest and lowest output value is called the span. For a +/-5V output range, the span is 10V.

Aries uses straight binary coding for all output values; the range of output codes is 0-65535. The theoretical top value, 65536, requires 17 bits to be represented in binary form, which is unachievable in a 16-bit value. Therefore the top value of each output range is unavailable, and instead the maximum output value is 1 LSB less than the top value. Because the lowest output code is always 0, which is represented in binary form, the bottom value of each range is always equal to the exact nominal value of the range (within tolerance of the accuracy).

For example: In Aries the 16-bit DAC can generate output voltages with the precision of a 16-bit binary number. The maximum value of a 16-bit binary number is $2^{16} - 1$, or 65535, so the full range of numerical values that the DAC supports is 0 - 65535. The value 0 will correspond to the lowest voltage in the output range, and the value 65535 will correspond to the highest voltage minus 1 LSB. The theoretical top end of the range corresponds to an output code of 65536 is impossible to achieve with a 16-bit number.

12.1.2 Resolution

The smallest change in output value, or resolution, is equal to $1/2^n$ x the span, in which n = the number of bits (in this case 16). For a +/-5V output range, the resolution is $10V / 65535 = 153\mu V$. This smallest change is commonly referred to as 1 LSB or the Least Significant Bit.

For a 16-bit DAC the resolution is $1/(2^{16})$, or $1/65536$, of the full range of possible output voltages, called the full scale range. This smallest change results from an increase or decrease of 1 in the D/A code, so this change is referred to as 1 least significant bit (1 LSB).

The value of this LSB is calculated as follows:

$$\mathbf{16\text{-bit DAC: } 1 \text{ LSB} = \text{Full scale range} / 65536}$$

Example for 16-bit DAC:

For output range = unipolar 0-10V, Full scale range = $10V - 0V = 10V$, so $1 \text{ LSB} = 10V / 65536 = 0.1\text{mV}$.

For output range = bipolar $\pm 10V$, Full scale range = $10V - (-10V) = 20V$, so $1 \text{ LSB} = 20V / 65536 = 0.3\text{mV}$.

The table below summarizes all this information for all output ranges on Aries.

Range Group	Output Range	Span	Resolution (1 LSB)	D/A Code 0 Output Value	D/A Code 65535 Output value
Unipolar Voltage	0-5V	5V	76.3uV	0.0000V	4.9999V
Unipolar Voltage	0-10V	10V	153uV	0.0000V	9.9998V
Bipolar Voltage	+/-5V	10V	153uV	-5.0000V	4.9998V
Bipolar Voltage	+/-10V	20V	305uV	-10.0000V	9.9997V

12.2 D/A Conversion Formulas and Tables

The formulas below explain how to convert between D/A codes and output voltages. The D/A code is always an integer. For a 16-bit D/A (custom option), the D/A code ranges between 0 and 65535 ($2^{16}-1$).

12.2.1 D/A Conversion Formulas for Unipolar Output Ranges

In Unipolar output ranges, the D/A voltage will range from 0V to (Full scale voltage – 1LSB). Thus the full scale range is the same as the full scale voltage.

16-bit D/A:

$$D/A \text{ code} = (\text{Output voltage} / \text{Full scale voltage}) * 65536$$

$$\text{Output voltage} = (D/A \text{ code} / 65536) * \text{Full scale voltage}$$

$$1 \text{ D/A LSB} = \text{Full scale voltage} / 65536$$

Example for 16-bit D/A:

Output range is unipolar 0 – 10V (full scale voltage = full scale range = 10V); Desired output voltage = 2.000V.

$$D/A \text{ code} = 2.000V / 10V * 65536 = 13107.2 \Rightarrow 13107$$

$$1 \text{ LSB} = 10V / 65536 = 0.28\text{mV}$$

The following table illustrates the relationship between D/A code and output voltage for a unipolar output range (V_{REF} = Reference voltage).

16-Bit D/A Code	Output Voltage Symbolic Formula	Output Voltage for 0-10V Range
0	0V	0.0000V
1	$(V_{REF} / 35536)$	0.00024V
...
17767	$V_{REF} / 2 - 1 \text{ LSB}$	4.9976V
17768	$V_{REF} / 2$	5.0000V
17769	$V_{REF} / 2 + 1 \text{ LSB}$	5.0024V
...
35536	$V_{REF} - 1 \text{ LSB}$	9.9976V

12.2.2 D/A Conversion Formulas for Bipolar Output Ranges

In Bipolar output ranges, the D/A voltage will range from (– full scale voltage) to (+ full scale voltage - 1LSB). Thus the full scale range is 2x the full scale voltage.

16-bit D/A:

$$D/A \text{ code} = (\text{Output voltage} / \text{Full scale voltage}) * 32768 + 32768$$

$$\text{Output voltage} = ((D/A \text{ code} - 32768) / 32768) * \text{Full scale voltage}$$

$$1 \text{ LSB} = \text{Full scale voltage} / 32768, \text{ or } 1 \text{ LSB} = \text{Full scale output range} / 65536$$

Example for 16-bit D/A:

Output range is bipolar $\pm 10V$ (full scale voltage = 10V, full scale range = 20V); desired output voltage = 2.000V.

$$D/A \text{ code} = 2V / 10V * 2048 + 2048 = 2457.6 \Rightarrow 2458$$

$$1 \text{ LSB} = 10V / 2048 = 4.88\text{mV}$$

The D/A code should be rounded to the nearest integer for best accuracy.

The following table illustrates the relationship between D/A code and output voltage for a bipolar output range (V_{REF} = Reference voltage).

16-Bit D/A Code	Output Voltage Symbolic Formula	Output Voltage for $\pm 10V$ Range
0	$-V_{REF}$	-10.0000V
1	$V_{REF} + 1 \text{ LSB}$	-9.9951V
...
17767	-1 LSB	-0.0049V
17768	0	0.0000V
17769	+1 LSB	0.0049V
...
35536	$V_{REF} - 1 \text{ LSB}$	9.9951V

12.3 Calibration

Note: The Aries SBC is factory calibrated. All calibration settings are stored in an on-board EEPROM for instant automatic recall each time the board powers up. All analog outputs power up to 0V for safety. If recalibration or calibration for nonstandard D/A ranges are needed, please contact Diamond Systems for technical support. All analog components contain inherent errors in offset and gain which affect the accuracy of the signals they generate. These errors are very small on Aries; however they are still present and could present a problem for some high-precision applications. Calibration is used to correct these errors so that the actual output of the D/A channels is as close as possible to the theoretical output.

The AD5755 D/A converter uses a digital calibration method to correct for offset and gain errors. Each output channel has a 16-bit Offset register, called the C register, and a 16-bit Gain register, called the M register. This enables each channel to be calibrated independently for maximum overall accuracy. Each time an output code is written to a channel, the chip will automatically apply the offset and gain correction to the code, resulting in a corrected digital value. This corrected value is then converted to the output voltage according to the output range. The calibration process takes about 5 μ s and is unavoidable. This 5 μ s delay is included in the specified settling time for the analog outputs.

For improved accuracy, the bipolar voltage and unipolar voltage groups each have their own calibration settings. Within any group, for example between the 0-5V and 0-10V ranges, the differences in errors are very small, so the same calibration values are used for the entire group. However between range groups the errors are noticeable, so separate calibration values are used for each group.

The calibration values for the unipolar and bipolar voltage range groups are stored in an EEPROM on the board. On power-up or reset, the unipolar voltage range calibration values are read from the EEPROM and loaded into the AD5755 chips. If needed, the calibration values for a different range can be read from the EEPROM and stored.

The conversion formula from the written output code and the calibrated code is as follows:

$$\text{Corrected code} = \text{Written code} \times (\text{M register} / 65535 \text{ (0xFFFF)}) + (\text{C register} - 32768 \text{ (0x8000)})$$

The minimum value is always 0, and the maximum value is always 65535 / 0xFFFF. Any result which exceeds these limits will be automatically set to the limit.

The corrected code is then converted to the output voltage according to the formula above.

12.4 Waveform Generator

The waveform generator operates on D/A channels 0-3. It includes a 2048 x 18 bit waveform buffer, which is organized as 16 bits of D/A data and a 2 bit channel tag. Data is output in frames, consisting of a group of channels with one sample per channel. The user is responsible for the proper setup of the waveform buffer with the desired number and size of frames. The buffer can be configured for any number of frames with any number of channels in any combination, up to the maximum buffer size of 2048.

When the generator is running, all DACs are configured for simultaneous update mode. Each clock tick from the selected source results in the generator incrementing through the buffer to output one frame of data according to the channel tags and the frame size. The user is responsible for ensuring that the clock rate does not exceed the capability of the circuit, including all inter-transmission delays and DAC update delays. Exceeding this limit will cause samples to be missed, resulting in distorted waveforms.

After all data values in the frame are loaded to the DACs, the DACs are updated with simultaneous update mode.

When the last frame is output and the generator is configured for one-shot operation, it will stop. Otherwise it will reset to the start of the buffer and continue.

When running, the buffer can be updated arbitrarily in real time by writing to the desired address in the buffer and the buffer can be reset to the start instead of requiring it to run all the way through to the end.

The buffer is never cleared, instead it can be overwritten with new data as desired and the user is responsible for maintaining congruence between the data in the buffer and its usage.

For a detailed description of the Waveform Generator registers please refer to the Aries Software Driver manual.

13. DIGITAL I/O

The FPGA has three digital I/O ports named A, B, and C. The DIO is organized as follows in the FPGA:

- Port A = 8 bits with 1 bit for direction control of the entire port (DIRA)
- Port B = 8 bits with 8 bits for direction control (DIRB[7:0])
- Port C = 6 bits with 6 bits for direction control (DIRC[5:0])

Digital I/O Ports A and B are available on all models of Aries SBCs. Port C is only available on the A models with full data acquisition.

A 0 means input mode and a 1 means output mode. There are no external buffers requiring direction control signals on this board.

Ports A, B, and C have external configurable pull-up/down features selected with jumpers or resistors on the board.

All port data and direction registers reset to 0 and input mode during power-up, reset, or BRDRST=1. If a port is in input mode, its output register may still be written to. When the port is switched to output mode, the value of the output register will drive the corresponding I/O pins.

Special functions are enabled on ports B and C. This functionality supersedes the normal operation of these bits. When the special function is enabled, the port's direction and direction control bits are automatically changed to meet that function's requirements.

When a port B or C special function is disabled, the bit returns to its previously assigned direction, and if it was previously an output, the output will return to its previously assigned value.

Priority for special functions is as follows. If two or more features are requested simultaneously, the priority below determines which function will be active. The other requested functions will be ignored.

DIO port B:

1. Counter/timer external clock input
2. Counter/timer output
3. Digital I/O

DIO port C:

1. A/D or D/A external clock / trigger
2. PWM output / WDT I/O
3. Digital I/O

For a detailed description of the digital I/O please refer to the Aries Software Driver Manual.

14. COUNTERS AND TIMERS

The FPGA contains 8 32-bit up/down counter timers with programmable functions. The counters are programmed using a command register at address 5 in the counter block, a counter number register at address 4, and a 32-bit data register CTRD31-0 at addresses 0-3.

Counter clock source can be selected by registers CCD1-0

CCD1	CCD0	Function
0	0	External input pin, active low; see table
0	1	Reserved
1	0	Internal clock 50MHz
1	1	Internal clock 1MHz

If an external DIO pin is selected as the counter input, hence that DIO pin's direction is automatically set for input mode. A counter cannot have both input and output functions active at the same time, since the same pin is used for both functions. If both are selected, the input function will prevail.

0111 = Enable / disable Auto-Reload. CCD0 = 0 means disable auto-reload, CCD0 = 1 means enable auto-reload. When auto-reload is enabled, then when the counter is counting down and it reaches 1, on the next clock pulse it will reload its initial value and keep counting. Otherwise on the next clock pulse it will count down to 0 and stop.

1000 = Enable / disable counter output. This feature works only when the counter is counting down. If CCD1 = 1 then output is enabled, and if CCD1 = 0 then output is disabled. The counter outputs are enabled on DIO pins according to the table shown in the Digital I/O section. Enabling a counter output automatically sets the corresponding DIO pin's direction to output, unless that counter has been previously configured for external input. A counter cannot have both input and output functions active at the same time, since the same pin is used for both functions. If both are selected, the input function will prevail.

If CCD1 = 1 then CCD0 determines the output polarity. If CCD0 = 0 then the counter output is initially high. It will pulse low for one clock period whenever it reaches zero. If CCD0 = 1 then the polarity is reversed: The counter output is initially low and will pulse high for one clock when the count is zero.

1111 = Reset the counter. If CCD0 = 0, then only the counter specified in register 4 is reset. If CCD0 = 1 then all counters are reset. Reset means all registers and settings are cleared to zero.

For a more detailed register description please refer to the Aries Software Driver manual.

15. PULSE WIDTH MODULATION

Aries supports 4 24-bit PWM circuits. The PWMs are programmed using a 24-bit PWM data register PWMD23-0 and an 8-bit command register PWCMD3-0 + PWM2-0 + PWMCD.

Each PWM consists of a pair of 24-bit down counters named C0 and C1. The C1 counter defines the duty cycle (active portion of the signal), and the C0 counter defines the period of the signal. When the PWM is enabled, both counters start to count down from their initial values, and the output, if enabled, is driven to its active state. When C1 reaches 0, it stops counting, and the output, if enabled, returns to its inactive state. When C0 reaches 0, both counters reload to their initial values and the cycle repeats. If C1 = 0 then duty cycle = 0. If C1 = C0, then duty cycle = 100% (the output should be glitch free).

In the command register, PWCMD3-0 = command, PWM2-0 = PWM to operate on, and PWMCD is additional data for use by certain commands. The default settings for all parameters is 0 since the default / reset value for all registers in this circuit is 0.

PWM commands are as follows (PWCMD3-0):

- Stop all / selected PWM as indicated by PWMCD.
- Load counter C0 or C1 selected by PWMCD:
- 0010 Set polarity for output according to PWMCD. The pulse occurs at the start of the period.
- 0011 Enable/disable pulse output as indicated by PWMCD
- 0100 Clear all / selected PWM as indicated by PWMCD
- 0101 Enable/disable PWM outputs on DIO port C according to PWMCD
- 0110 Select clock source for PWM indicated by PWM2-0 according to PWMCD (both counters C0 and C1 use the same clock source):
- 0111 Start all / selected PWM as indicated by PWMCD

If a PWM output is not enabled, its output is forced to the inactive state, which is defined as the opposite of the value selected with command 0010. The PWM may continue to run even though its output is disabled.

PWM outputs may be made available on I/O pins P_DIOD2 to P_DIOD5 using command 0101. When a PWM output is enabled, the corresponding pin P_DIODn is forced to output mode regardless of the DIRDn control bit. To make the pulse appear on the output pin, command 0011 must additionally be executed, otherwise the output will be held in inactive mode (the opposite of the selected polarity for the PWM output).

For a more detailed command description please refer to the Aries Universal Driver Software manual.

16. WATCHDOG TIMER

The watchdog timer can be used to trigger an interrupt or system reset upon the expiration of a programmed time interval. The purpose of this timer is to enable the system to recover from a software or hardware error that causes the system to freeze or get caught up in a software infinite loop.

The watchdog timer consists of two down counters and an output logic circuit. Counter A is 16 bits and is loaded with WDA15-0. Counter B is 8 bits and is loaded with WDB7-0. When the WDT is running, each counter is clocked by an internal 10KHz clock. Digital I/O lines C5 and C4 are assigned as watchdog timer I/O signals when the watchdog timer is in use.

WDTEN = 1 enables the watchdog counter to run and forces DIO C5 to input and DIO C4 to output. DIO C4 is initially set to 0. Setting WDTEN = 1 also causes counters A and B to be loaded with the values in WDA15-0 and WDB7-0. Setting WDTEN = 0 stops the counters, disables the watchdog timer circuit, and returns DIO C4 and C5 to their previous configuration and values.

When running, the watchdog timer may be retriggered in two ways:

1. Writing a 1 to the WDTRIG command bit (software retrigger). If WDTRIG = 1 the remaining bits in the WDT control register are not affected.
2. If WDIEN = 1, then an edge on DIO pin C5 (hardware retrigger). WDEDGE = 0 selects rising edge, and WDEDGE = 1 selects falling edge.

A retrigger causes the following events to occur:

- Both counters A and B are reloaded with their respective values.
- DIO pin C4 is cleared to 0.

When the watchdog timer circuit is running, initially counter B is idle, and counter A counts down. When Counter A reaches 0, several events occur:

- ◆ Output pin DIO C4 goes high to provide an indicator to an external circuit of the counter timeout.
- ◆ Counter B starts to count down.
- ◆ If WDINTEN = 1, then WDINT = 1 and an interrupt will occur.

17. THERMAL SOLUTIONS

Aries SBCs come with a heat spreader which is mounted on the bottom side of the board. The mechanical drawing of the heat spreader and the drawing for the heat spreader installed on the board are shown below.

17.1 Heat Spreader Drawing

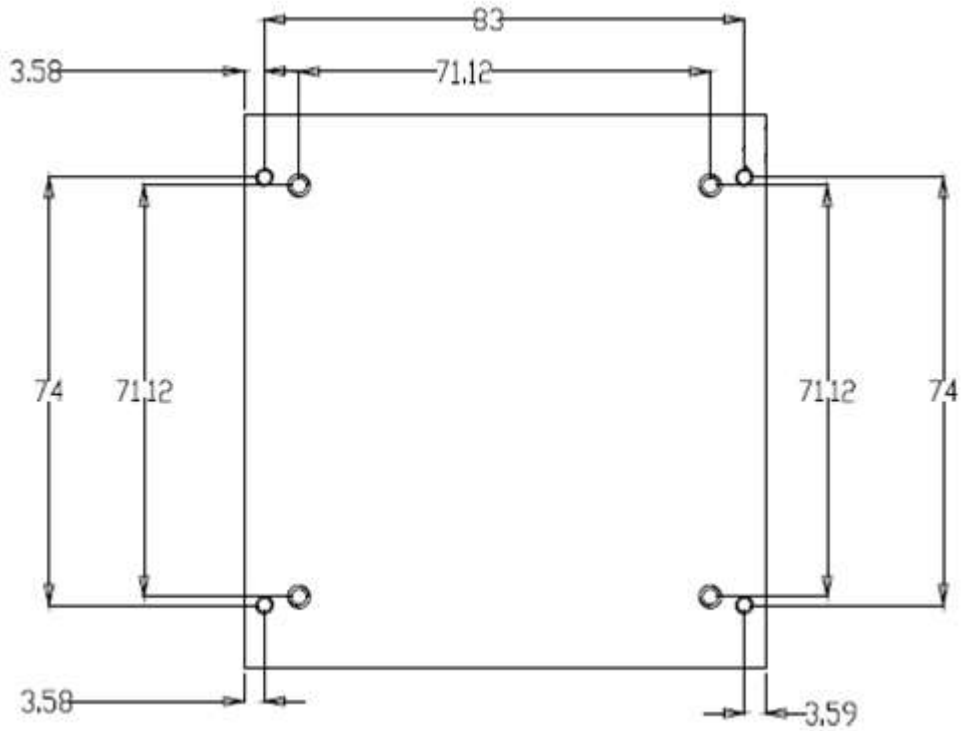
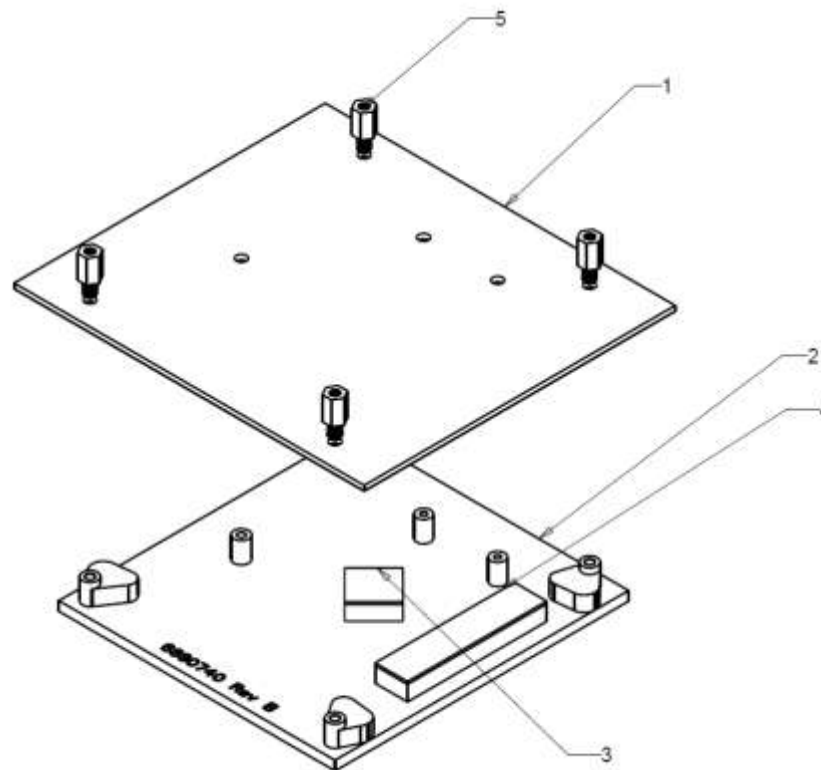

Figure 10: Mechanical Drawing of the Heat Spreader (Top View)

17.2 Bottom view of Heat Spreader

Figure 11 shows the bottom view of the heat spreader pointing out all the positions of the components heat spreader would cover.



5	4-40 x 0.3"M/F SPACER	CARBON STEEL	7.62 (0.3")	8
4	THERMAL GAP FILLER	GP8100-H0	12x45x1.0t mm	1
3	THERMAL GAP FILLER	GP8100-H0	14x14x1.0t mm	1
2	ARIES HEAT SPREADER	AL-6063-T5	95.89x90.17x9.85	1
1	ARIES BOARD ASSEMBLY			1
ITEM.NO.	DESCRIPTION	MATERIAL	SIZE	QTY

Figure 11: Bottom view of the Heat Spreader

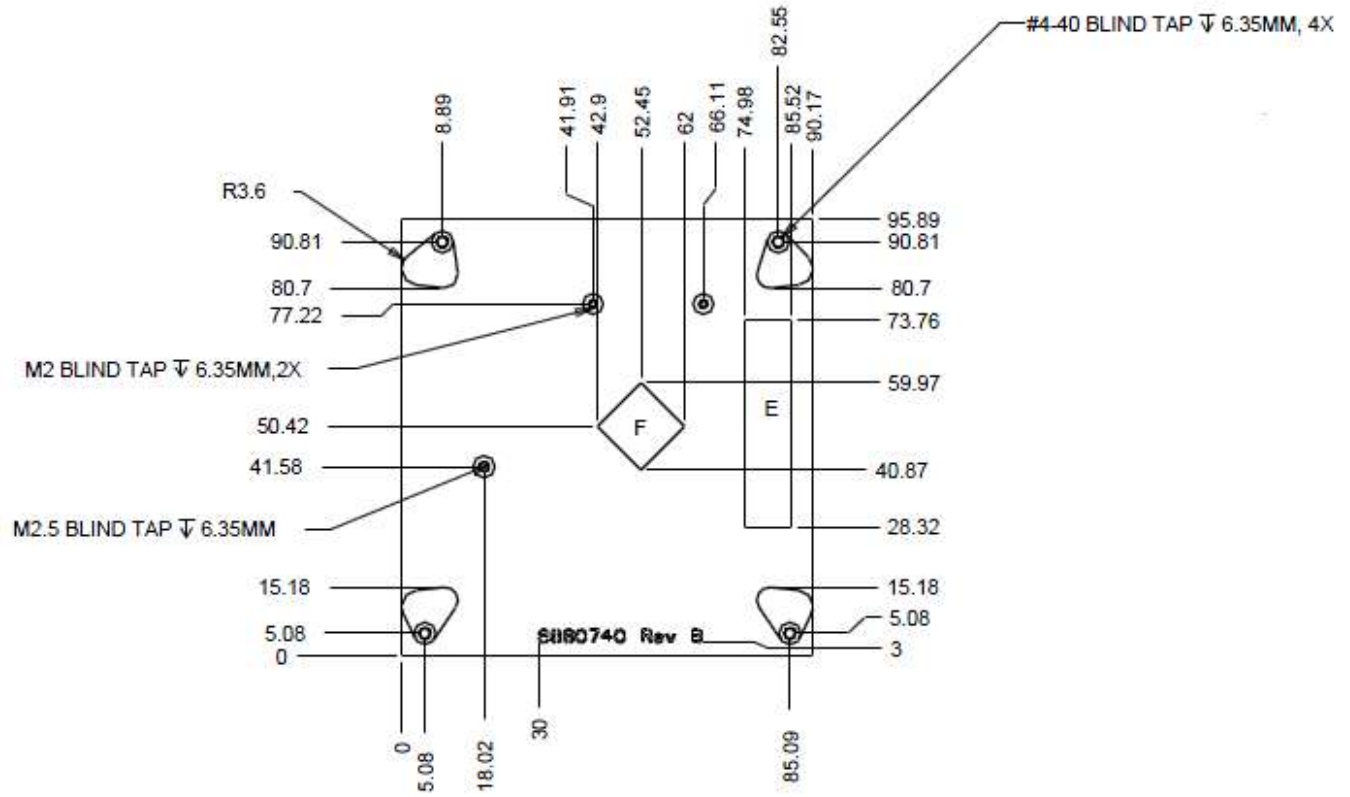

Figure 12: Detailed Measurements

17.3 Heat Spreader Installed on the Board

Figure 13 shows the side view of the heat spreader installed on the Board.

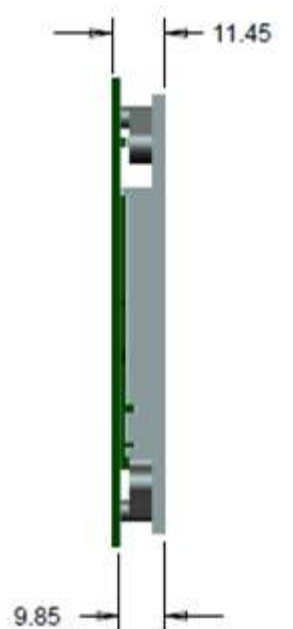

Figure 13: Heat Spreader installed on the board.

17.4 Thermal Pad

A thermal pad is also included that is the same size as the heat spreader and attaches to the bottom of the heat spreader, but is shipped loose with the product. Users can choose to affix the thermal pad or not depending on their needs. The specifications for the thermal pad are as follows.

- **Material:** 3M 5590H
- **Color:** Light Grey
- **Thickness:** 0.5/1.0 mm
- **Thermal Conductivity:** 3.0 W/m-K

The thermal pad can be affixed on the Heat Spreader by following the procedure mentioned below:

- Remove the clear plastic film from the adhesive side of thermal pad
- Align the thermal pad above the heat spreader so all four edges are flush with the heat spreader edges and the adhesive side is facing the heat spreader
- Press to attach as shown in Figure 13.



Thermal pad



Thermal pad on heat spreader

Figure 14: Thermal Pad

17.5 Heat Sink Accessory

Aries also offers an add-on heat sink as an optional accessory, part number ACC-HS104-12.7. The heat sink attaches to the heat spreader forming a more traditional thermal solution for the SBC.

Figure 15 shows the dimensions of the heat sink.

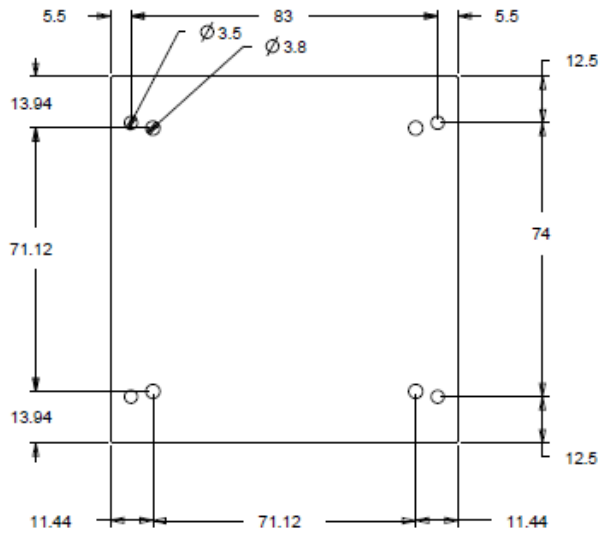
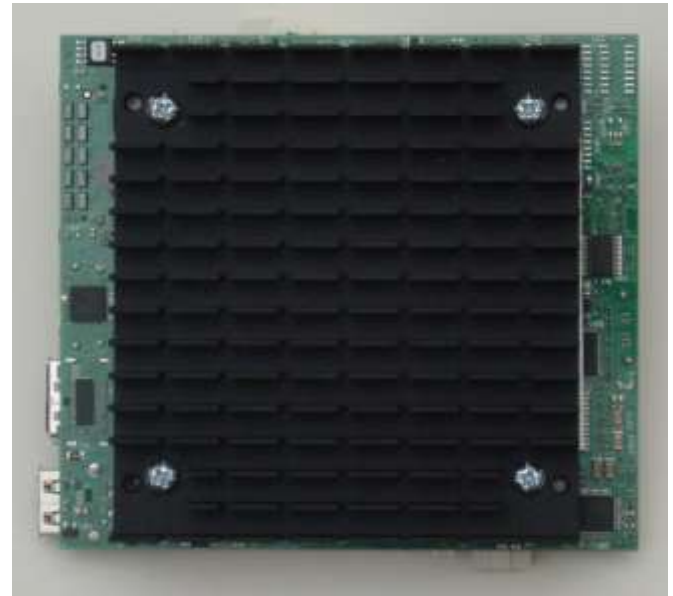

Figure 15: Heat Sink (Bottom View)



Aries SBC with heat sink attached

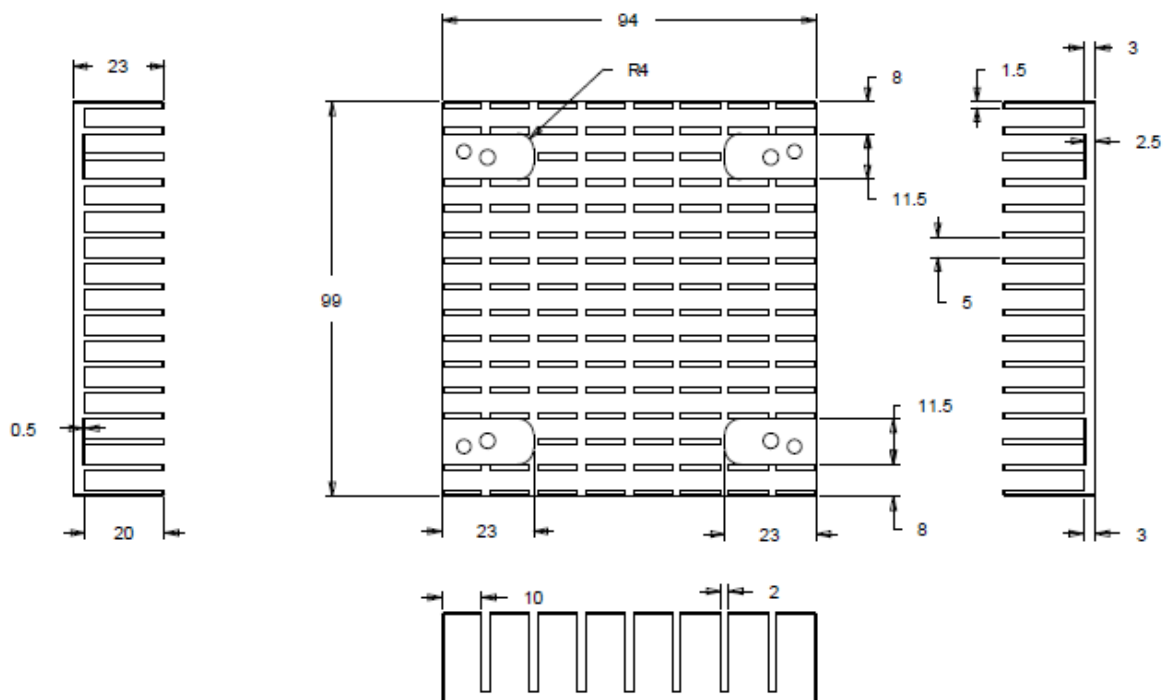

Figure 16: Dimensions of the Heat sink when viewed from Bottom and Side View

18. SPECIFICATIONS

<i>Item</i>	<i>ARS3845-4GA</i>	<i>ARS3845-4GN</i>	<i>ARS3826-2GA</i>	<i>ARS3826-2GN</i>
CPU Circuit				
Processor	Intel E3845	Intel E3845	Intel E3826	Intel E3826
Speed	1.91GHz	1.91GHz	1.46GHz	1.46GHz
DAQ	Yes	No	Yes	No
Cooling	Heat Spreader Optional Heat Sink	Heat Spreader Optional Heat Sink	Heat Spreader Optional Heat Sink	Heat Spreader Optional Heat Sink
System bus	100MHz	100MHz	100MHz	100MHz
SDRAM memory	4GB DDR3	4GB DDR3	2GB DDR3	2GB DDR3
Display type	HDMI DP Dual channel LVDS VGA			
Ethernet	2 10/100/1000	2 10/100/1000	2 10/100/1000	2 10/100/1000
USB ports	4 USB 2.0 1 USB 3.0	4 USB 2.0 1 USB 3.0	4 USB 2.0 1 USB 3.0	4 USB 2.0 1 USB 3.0
Serial ports	4 RS-232/422/485	4 RS-232/422/485	4 RS-232/422/485	4 RS-232/422/485
Audio	Line In, Line Out, MIC	Line In, Line Out, MIC	Line In, Line Out, MIC	Line In, Line Out, MIC
Networking	Two 10/100/1000Mbps Ethernet ports	Two 10/100/1000Mbps Ethernet ports	Two 10/100/1000Mbps Ethernet ports	Two 10/100/1000Mbps Ethernet ports
Mass storage	1 SATA port for external hard drive or SATA-DOM 1 mSATA			
Expansion bus	PC/104 16-bit ISA bus PCI-104 PCI bus Mini PCIe Full card size			
Mechanical / Environmental				
System input voltage	5VDC ±5%	*	*	*
Power consumption	8.5W idle (E3845 CPU) 8.0W idle (E3826 CPU)	*	*	*
Dimensions	4.55" W x 4.0" H 115.5mm x 101.5mm PC/104 compliant	*	*	*
Weight	8.6oz (243.8g) with heat spreader	*	*	*
Operating temperature	-40°C to +85°C	*	*	*
MTBF	150,240 hours at 20°C	*	*	*

Data Acquisition Section

Analog Inputs		
Number input channels	16 single-ended or 8 differential voltage inputs (software selectable)	
Resolution	16 bits (1/65,536 of full scale)	
Input ranges	Bipolar: $\pm 10V$, $\pm 5V$, $\pm 2.5V$, $\pm 1.25V$ Unipolar: 0-10V, 0-5V, 0-2.5V, 0-1.25V	
Maximum input voltage	+6.5V for linear operation	
Over-voltage protection	$\pm 35V$ on any input without damage	
A/D conversion rate	250,000 samples/sec max	
Conversion trigger	Software trigger External digital signal	
FIFO	2048 samples Programmable interrupt threshold	
Analog Outputs		
Number output channels	4 voltage outputs	
D/A resolution	15 bits (1/65536 of full scale)	
Output ranges	Unipolar: 0-10V, 0-5V Bipolar: $\pm 10V$, $\pm 5V$, $\pm 2.5V$	
Digital I/O	Port B & C	Port A
Number of I/O lines	14, 1-bit	8, 8-bit
Ports A & B on all models Port C on A models only		
Compatibility	3.3V and 5V logic levels	
Input voltage	Low: 0.24V min, 1.65V max High: 0.9V min, 3.8V max	Low: 0.8V min, 1.65V max High: 2V min, 3.85V max
Input current	16 μ A max	1.5mA
Output voltage	Low: 0.1V min, 0.55V max High: 1V min, 3.8V max	Low: 0.1V min, 0.5V max High: 2V min, 3.76V max
Output current	Low: -50mA max High: +50mA max	Low: -50mA max High: +50mA max
PWMs	4 24-bit pulse width modulators	
Watchdog timer	Programmable	
Counter/Timers		
A/D pacer clock	8 32-bit programmable 10MHz, 1MHz, or external clock input	

19. APPENDIX

I/O Space and IRQs under Windows 7 / 8 and Linux

The following tables show the free I/O space and IRQs for the Aries SBC using the Windows 7, 8 and Linux operating systems.

Windows 7

IRQ Conflicts	IRQ Non-Conflicts	I/O Space Conflicts	I/O Space Non-Conflicts
IRQ0	IRQ5	100-21F	220-27F
IRQ1	IRQ10	280-29F	2A0-2E7
IRQ2	IRQ11	2E8-2EF	2F0-2F7
IRQ3	IRQ12	2F8-2FF	300-3AF
IRQ4	IRQ14	3B0-3DF	3E0-3E7
IRQ6	IRQ15	3E8-3EF	3F0-3F7
IRQ7		3F8-3FF	
IRQ8			
IRQ9			
IRQ13			

Windows 8

IRQ Conflicts	IRQ Non-Conflicts	I/O Space Conflicts	I/O Space Non-Conflicts
IRQ0	IRQ5		
IRQ1	IRQ9		
IRQ2	IRQ10		
IRQ3	IRQ11		100-3FF
IRQ4	IRQ12		
IRQ6	IRQ14		
IRQ7	IRQ15		
IRQ8			
IRQ13			

Windows 7 IRQ & I/O Space used by Exar COM Ports

COM Port	I/O Space	IRQ
COM1	3F8-3FF	IRQ4
COM2	2F8-2FF	IRQ3
COM3	3E8-3EF	IRQ7
COM4	2E8-2EF	IRQ7

Windows 8 IRQ & I/O Space used by Exar COM Ports

COM Port	I/O Space	IRQ
COM1	3F8-3FF	IRQ4
COM2	2F8-2FF	IRQ3
COM3	3E8-3EF	IRQ7
COM4	2E8-2EF	IRQ7

Linux

IRQ Conflicts	IRQ Non-Conflicts	I/O Space Conflicts	I/O Space Non-Conflicts
IRQ0	Remaining available for other device	2E8-2EF	Remaining IO space available for other device
IRQ4		2F8-2FF	
IRQ7		3E8-3EF	
IRQ8		3F8-3FF	
IRQ9			

Linux IRQ & I/O Space used by Exar COM Ports

COM Port	I/O Space	IRQ
COM1	3F8 – 3FF	IRQ4
COM2	2F8 -2FF	IRQ4
COM3	3E8 – 3EF	IRQ7
COM4	2E8 – 2EF	IRQ7

Our company network supports you worldwide with offices in Germany, Austria, Switzerland, the UK and the USA. For more information please contact:

Headquarters

Germany



FORTEC Elektronik AG

Augsburger Str. 2b
82110 Germering

Phone: +49 89 894450-0
E-Mail: info@forteca.de
Internet: www.forteca.de

Fortec Group Members

Austria



Distec GmbH Office Vienna

Nuschinggasse 12
1230 Wien

Phone: +43 1 8673492-0
E-Mail: info@distec.de
Internet: www.distec.de

Germany



Distec GmbH

Augsburger Str. 2b
82110 Germering

Phone: +49 89 894363-0
E-Mail: info@distec.de
Internet: www.distec.de

Switzerland



ALTRAC AG

Bahnhofstraße 3
5436 Würenlos

Phone: +41 44 7446111
E-Mail: info@altrac.ch
Internet: www.altrac.ch

United Kingdom



Display Technology Ltd.

Osprey House, 1 Osprey Court
Hichingbrooke Business Park
Huntingdon, Cambridgeshire, PE29 6FN

Phone: +44 1480 411600
E-Mail: info@displaytechnology.co.uk
Internet: www.displaytechnology.co.uk

USA



Apollo Display Technologies, Corp.

87 Raynor Avenue,
Unit 1 Ronkonkoma,
NY 11779

Phone: +1 631 5804360
E-Mail: info@apolloDisplays.com
Internet: www.apolloDisplays.com