



OUR GLOBAL
COMPETENCE
CENTRES

 APOLLO DISPLAY
TECHNOLOGIES



 DISTEC



 DISPLAY
TECHNOLOGY



Datasheet

Diamond Systems

Elton

ELTON Rugged Carrier for NVIDIA® Jetson™ AGX Xavier™ Module

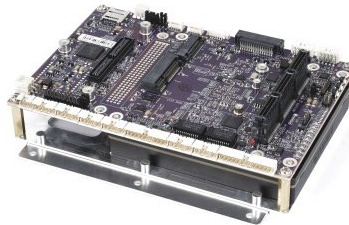

The information contained in this document has been carefully researched and is, to the best of our knowledge, accurate. However, we assume no liability for any product failures or damages, immediate or consequential, resulting from the use of the information provided herein. Our products are not intended for use in systems in which failures of product could result in personal injury. All trademarks mentioned herein are property of their respective owners. All specifications are subject to change without notice.

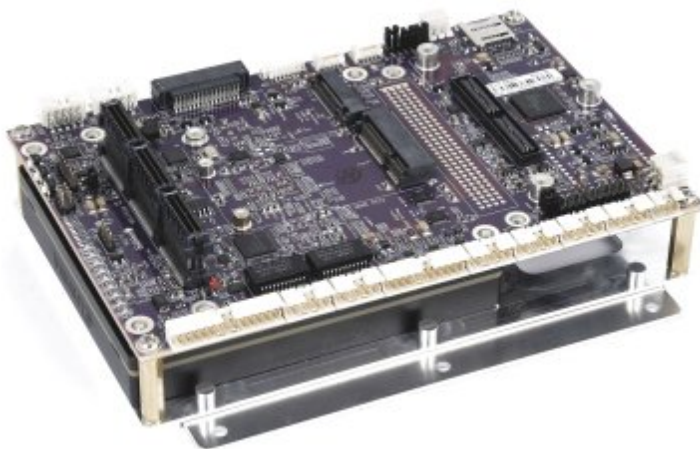
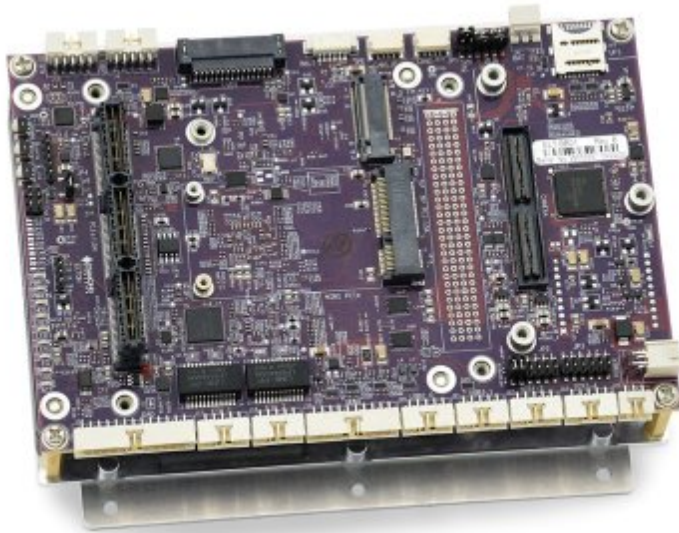

FEATURES

Size: 4" x 6.00" / 101.6 x 152.4mm

Input voltage 9-20VDC

On-board features:

I/O breakout from Xavier board:

- 2x USB 3.1

- 2x USB 2.0

- 2x Gigabit Ethernet

- 1x HDMI

- 1x LVDS LCD

- 4x RS-232/RS485/RS422

- 2x CAN 1Mbps

- Audio

SAM DAQ circuit:

- 6 12-bit A/D, 0-3.3V input range, up to 1MSPS sampling rate

- 2 12-bit D/A, 0-3.3V output range

- 13 GPIO, 3.3V logic levels

Socketed features:

- Camera module connector supports up to 6x 2-lane CSI cameras

- UFS flash socket

- M.2 PCIe x4 socket (2242 size)

- 1x Nimbelink™ Skywire® modem socket

PCI-104 Express expansion socket:

- PCI-104 connector for PCI bus

- 3-bank PCIe/104 Type 1 connector with 1x PCIe x8 and 4x PCIe x1

The PCIe/104

Complete assembly with Xavier module and heat spreader ACC-HSELT-01



Front edge contains most I/O connectors



Model ELT-BB01 with PCIe/104 expansion connector

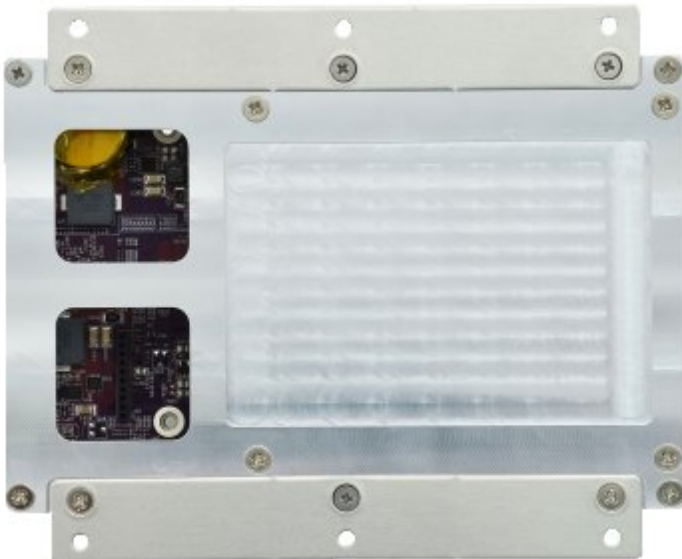

Bottom side of complete assembly showing heat spreader with internal mounting brackets

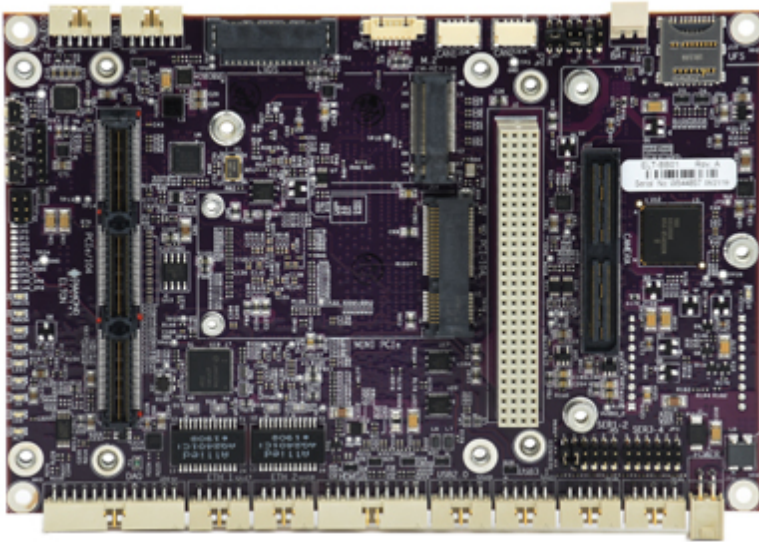

Model ELT-BB02 with PCIe/104 and PCI-104 connectors

◆ Ideal Platform for compute-intensive rugged embedded applications

With its NVIDIA Xavier computing power, rugged design, and PCIe/104 expansion capability, Elton offers the ideal platform for implementing high performance computing and AI applications in mobile and harsh environments.

Elton utilizes the NVIDIA Jetson AGX Xavier embedded computer module to deliver unmatched performance for AI, machine learning, image processing, and other compute-intensive tasks. The Xavier module delivers up to 30 TeraOps in performance (3×10^{13} operations per second) at a maximum power dissipation of 30 watts. Xavier also offers scalable performance for applications requiring lower overall power consumption of 10 or 15 watts. The module runs at 32 TOPs on a 512-core Volta GPU with Tensor Cores and accelerators, enabling high-performance AI-powered autonomous machines like never before. At 87 x 100mm (3.4 x 3.9") it is slightly bigger than the other Jetson modules.

Elton provides numerous sockets for I/O expansion. An industry-standard camera module socket supports the attachment of up to 8 CSI cameras (up to 4 cameras with 4K resolution). An M.2 socket supports the use of PCIe x4 NVMe flash storage up to 256GB. An LTE module socket supports the use of NimbLink SkyWire cellular modems, featuring a broad range of solutions with worldwide compatibility.

Standard PC-style I/O on Elton includes 2 USB 3.0 ports, 2 USB 3.1 ports, HD audio, HDMI and LVDS display, and 4 RS-232/422/485 ports with software configurability. All I/O is provided on pin headers that are compatible with both common non-latching and rugged latching mating cables, making Elton ideal for applications in environments subject to high shock and vibration.

◆ Unique and Rugged

◆ Elton Block Diagram

ELTON™ Xavier™ Carrier Block Diagram

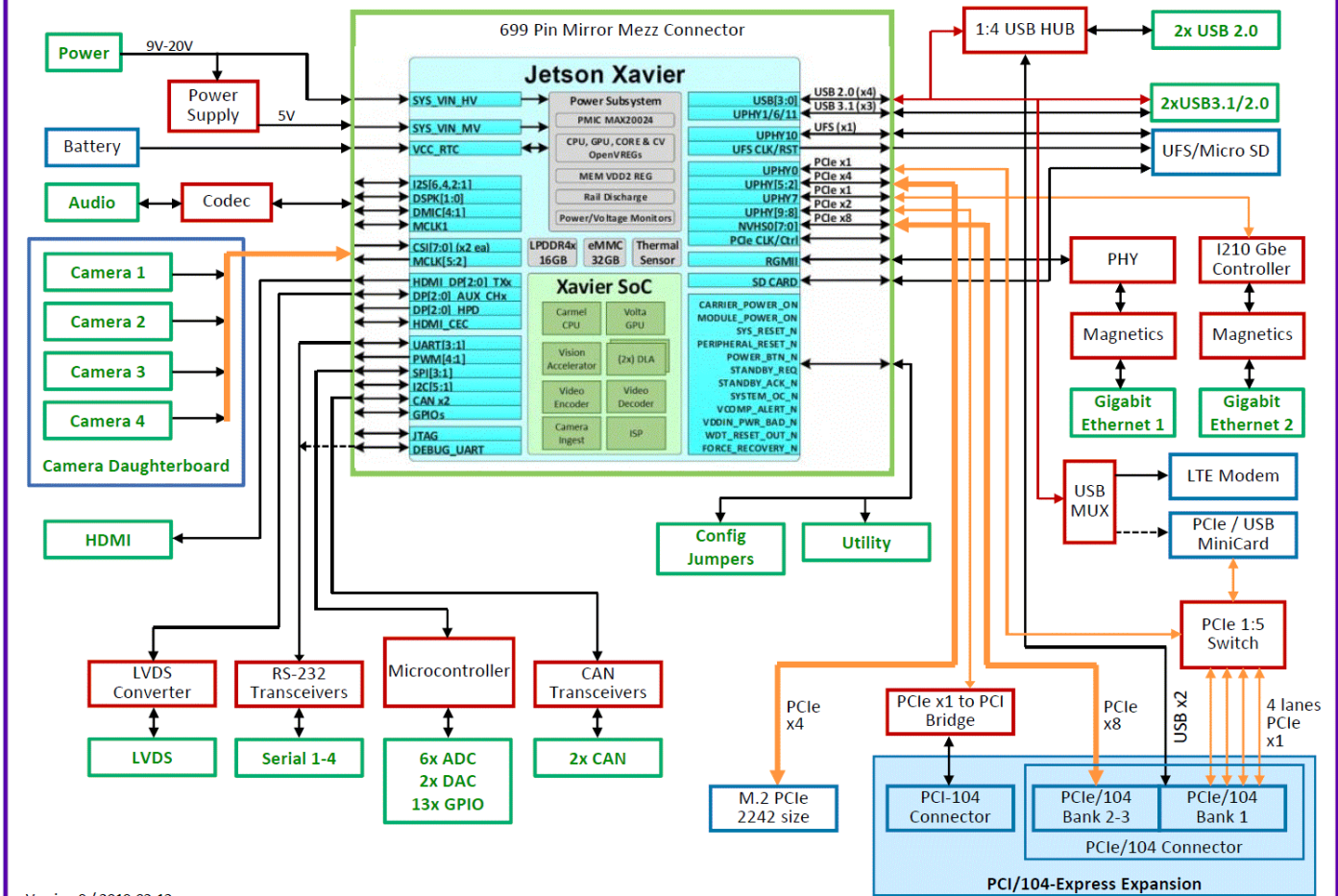

Version 9 / 2019-02-12

◆ Jetson Xavier Block Diagram

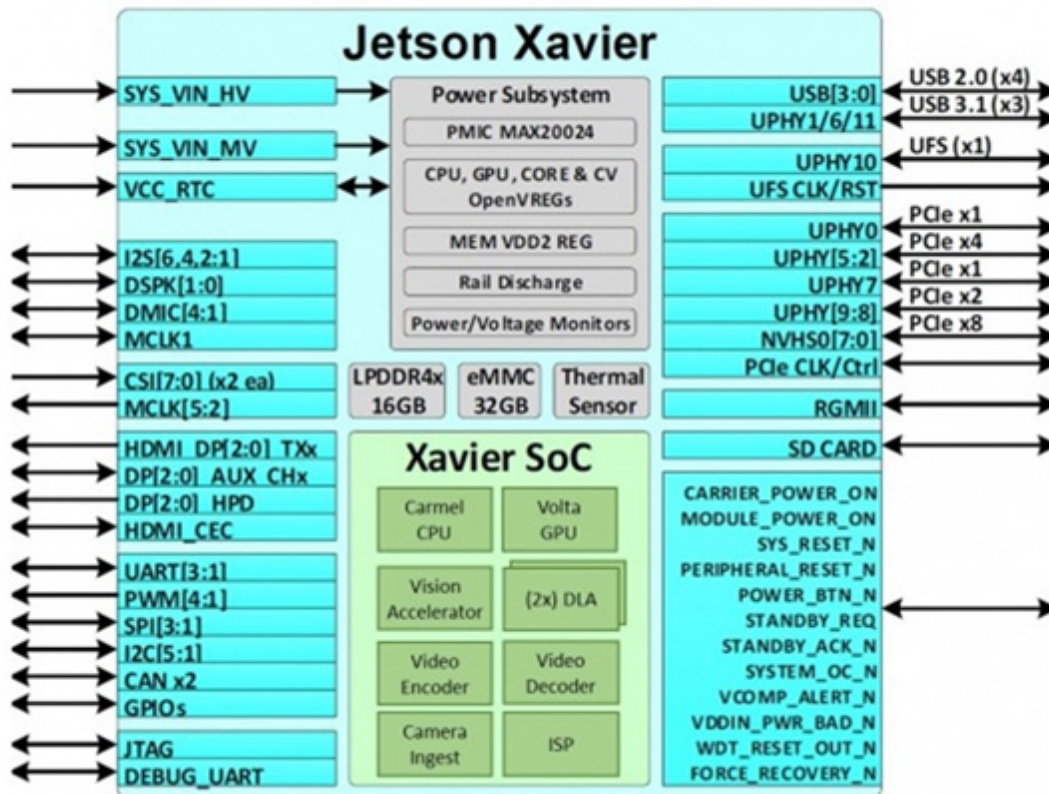

◆ NVIDIA Meets PC/104

Unique among NVIDIA computing module carriers, Elton employs a PCI/104-Express expansion socket. The socket provides support for PCI-104, PCIe/104 type 2 (x8 lane), and PCIe/104 OneBank expansion modules (4 x1 lanes), enabling rapid creation of truly rugged, custom-configured, high performance, PCIe-based solutions using off-the-shelf I/O modules from a large number of manufacturers worldwide. Typical PCIe/104 I/O expansion includes 1G/10G Ethernet, video capture, and high resolution video display. A wide variety of industrial I/O modules, including analog, digital, serial, motion control, and other types is also available.

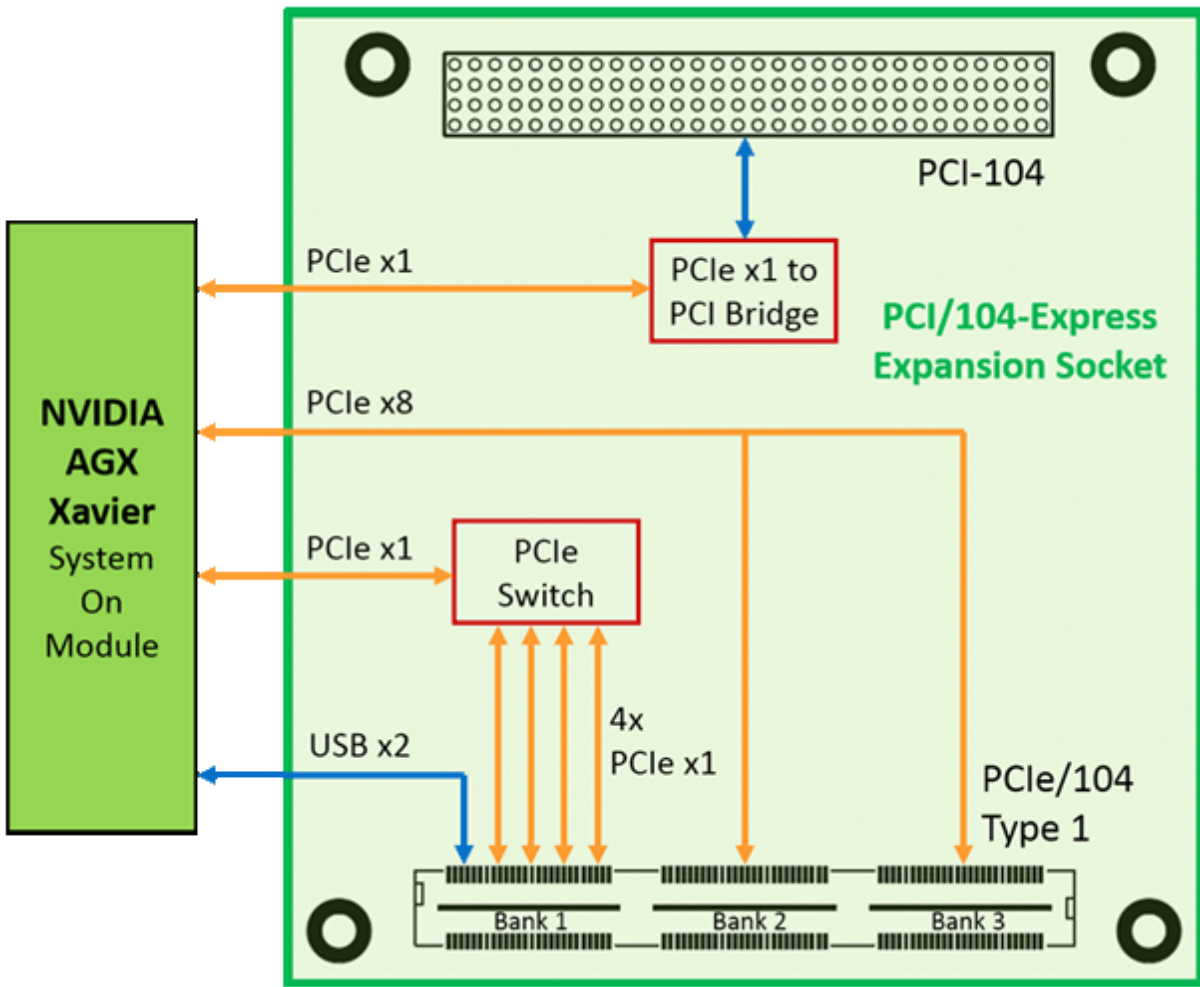

◆ Data Acquisition

A built-in data acquisition circuit provides 12-bit A/D up to 1MSPS, 12-bit D/A, and 3.3V GPIO. Diamond's free C-language programming library simplifies application development, while a GUI control panel offers convenient control and monitoring of real-world processes as well as ready-to-run data logging capability.

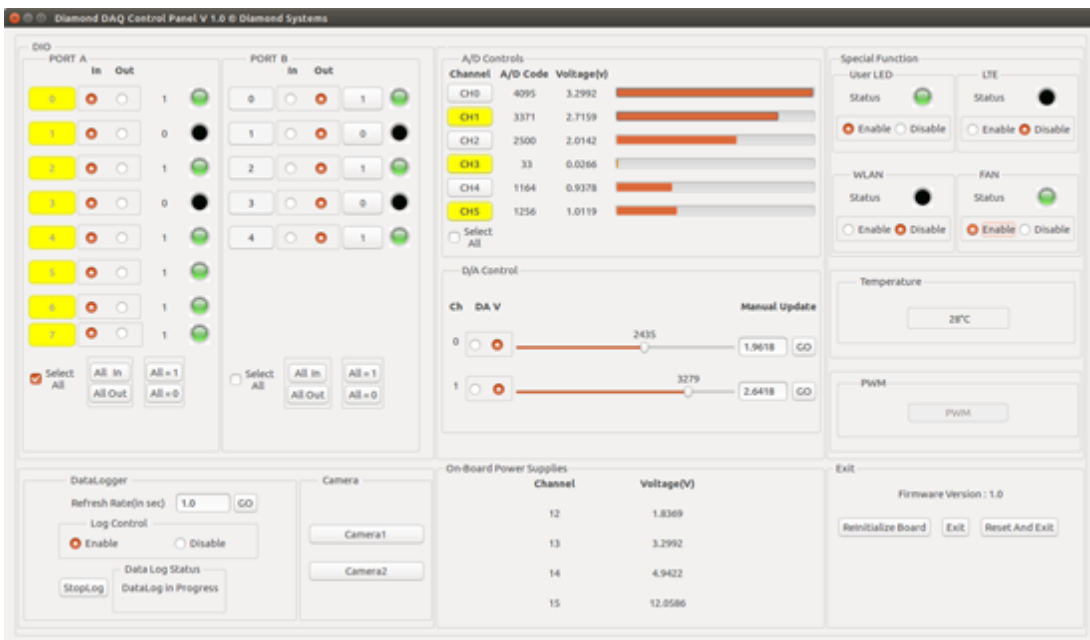

◆ Cable Kit

Cable kit for Elton Jetson Xavier carrier board, Latching board connectors

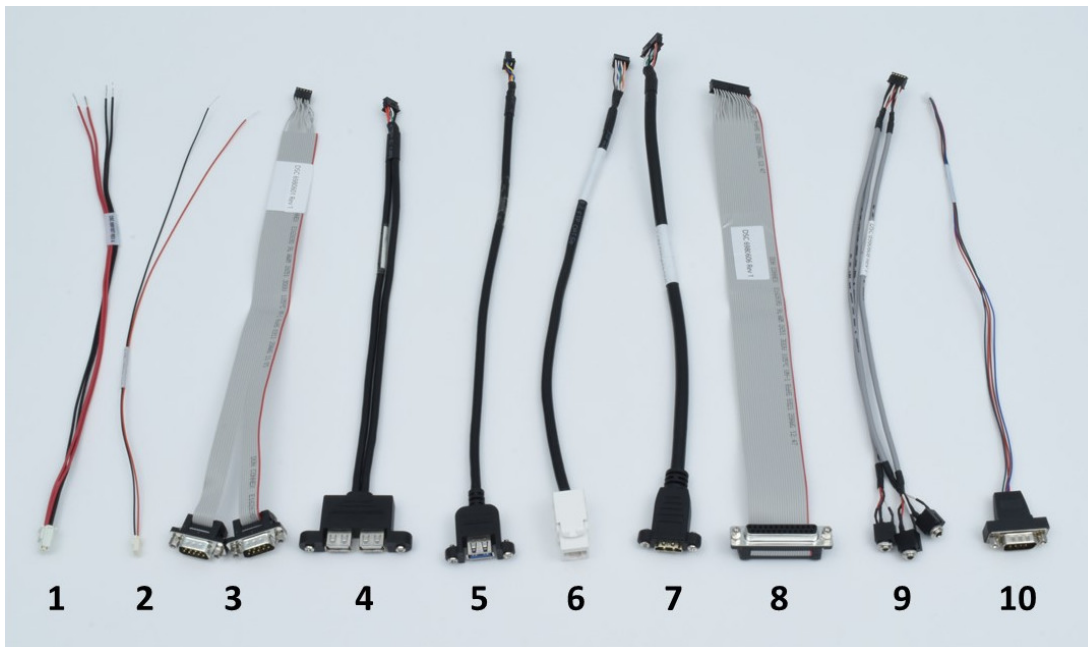

CK-ELTON-01 includes the following cables:

No.	Qty	Cable	Description	Drawing
1	1	6981507	Power Cable, IPD 2x2 to Leads, 20AV	Show
2	1	6980524	External battery cable, discrete wires	Show
3	1	6980601	Dual serial port cable, 2x DB9 male	Show
4	1	6980602	Dual USB 2.0 cable, 2x USB 2.0 type A	Show
5	1	6980603	Dual USB 3.0 type A, latching	Show
6	1	6980604	Ethernet cable, RJ-45 socket	Show
7	1	6980605	HDMI Cable	Show
8	1	6980606	DAQ Cable	Show
9	1	6980608	Audio cable, 3x 3.5mm jacks	Show
10	1	6981182	CANbus 2.0 cable, JST 1x4 to DB9M	Show

Rugged Design

Elton includes a suite of rugged features that make it ideal for applications requiring rugged, reliable performance:

PCI/104-Express expansion: Unique in the Nvidia ecosystem, Elton bridges the world of Nvidia higher performance computing and image processing capabilities with the world of PC/104 rugged systems. Elton includes a PCI/104-Express expansion socket with PCIe x8, PCIe x1, and optional PCI expansion capabilities to enable the installation of hundreds of I/O boards to provide additional I/O capabilities.

Wide temperature operation: Elton is designed to operate over the full -40 to +85C industrial temperature range, making it the perfect companion to the ATX Xavier Industrial module for harsh environment applications.

Thicker PCB: A 50% thicker PCB (2.3mm vs. 1.6mm typical) helps resist flexing that can lead to broken solder joints in high vibration environments.

Latching connectors: Virtually all connectors offer positive latching to prevent disconnection due to shock and vibration.

Conduction cooling: A bottom side combination heat spreader / mounting plate with embedded thermal pads provides the ultimate in thermal dissipation as well as convenient mounting inside the enclosure.

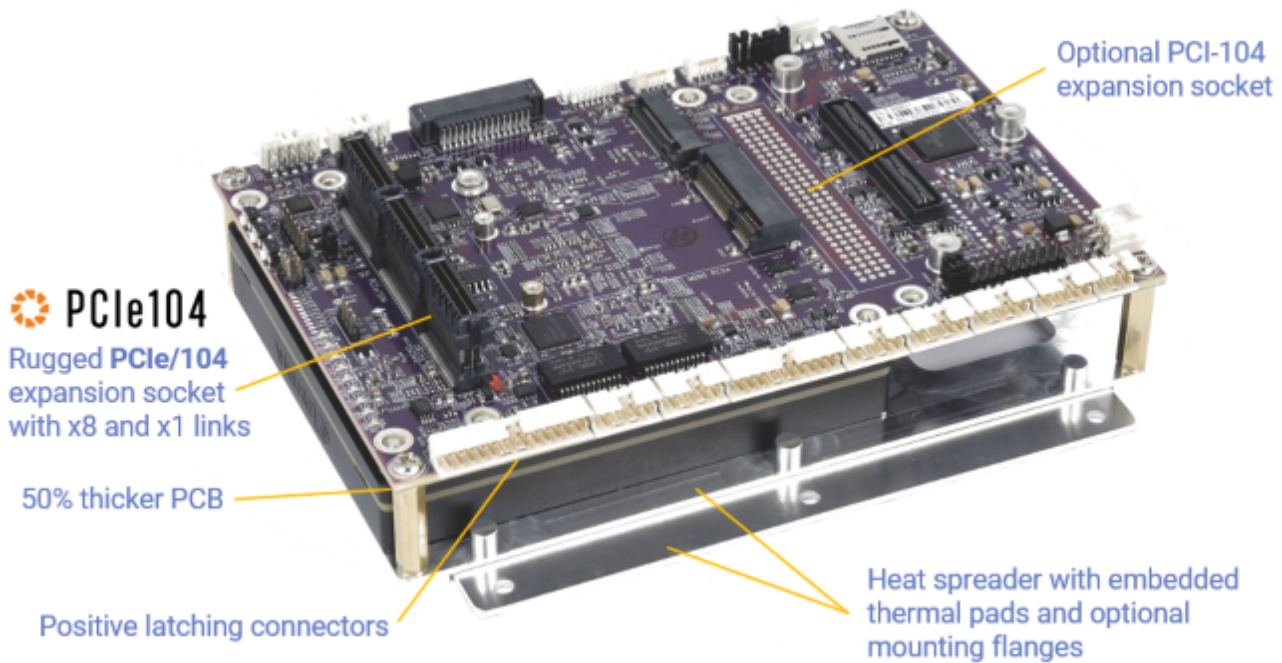

Ordering Information

Models and Accessories

ELTON

available models:

ELT-BB01	Elton carrier board for Jetson AGX Xavier computer on module with PCIe/104 expansion	Available
ELT-BB02	Elton carrier board for Jetson AGX Xavier computer on module with PCIe/104 + PCI-104 expansion	Available
ELT-BB03	Elton carrier board for Jetson AGX Xavier computer on module, no PCIe/104 / PCI-104 expansion	Min Order Quantity
ELT-AGX32-01	AGX Xavier 32GB installed on ELTON BB01 carrier board with OS installed, with heat spreader mounting plate	Available
ELT-AGX32XT-01	AGX Xavier 32GB Industrial module installed on ELTON BB02 carrier board with OS installed, with heat spreader mounting plate	Available
ELT-AGX64-01	AGX Xavier 64GB installed on ELTON BB01 carrier board with OS installed, with heat spreader mounting plate	Available
ELT-AGX32-02	AGX Xavier 32GB installed on ELTON BB01 carrier board with OS installed, with heat spreader mounting plate	Available
ACC-HSELT-01	Heat spreader for Elton carrier board	Available

Please [login](#) or [signup](#) for an online quote request.

Cables and accessories

available models:

CK-ELTON-01	Cable kit, Elton Latching type
6981507	Power Cable, IPD 2x2 to Leads, 20AV
6980524	External battery cable, discrete wires
6980601	Dual serial port cable, 2x DB9 male
6980602	Dual USB 2.0 cable, 2x USB 2.0 type A
6980603	Dual USB 3.0 type A, latching
6980604	Ethernet cable, RJ-45 socket
6980605	HDMI Cable
6980606	DAQ Cable

6980608 Audio cable, 3x 3.5mm jacks

6981182 CANbus 2.0 cable, JST 1x4 to DB9M

Please [login](#) or [signup](#) for an online quote request.

www.diamondsystems.com | [Sunnyvale, California USA](#) | [+1-650-810-2500](tel:+1-650-810-2500) | sales@diamondsystems.com

Our company network supports you worldwide with offices in Germany, Austria, Switzerland, the UK and the USA. For more information please contact:

Headquarters

Germany



FORTEC Elektronik AG

Augsburger Str. 2b
82110 Germering

Phone: +49 89 894450-0
E-Mail: info@fortecaq.de
Internet: www.fortecaq.de

Fortec Group Members

Austria



Distec GmbH Office Vienna

Nuschinggasse 12
1230 Wien

Phone: +43 1 8673492-0
E-Mail: info@distec.de
Internet: www.distec.de

Germany



Distec GmbH

Augsburger Str. 2b
82110 Germering

Phone: +49 89 894363-0
E-Mail: info@distec.de
Internet: www.distec.de

Switzerland



ALTRAC AG

Bahnhofstraße 3
5436 Würenlos

Phone: +41 44 7446111
E-Mail: info@altrac.ch
Internet: www.altrac.ch

United Kingdom



Display Technology Ltd.

Osprey House, 1 Osprey Court
Hinchingsbrooke Business Park
Huntingdon, Cambridgeshire, PE29 6FN

Phone: +44 1480 411600
E-Mail: info@displaytechnology.co.uk
Internet: www.displaytechnology.co.uk

USA



Apollo Display Technologies, Corp.

87 Raynor Avenue, Unit 1
Ronkonkoma, NY 11779

Phone: +1 631 5804360
E-Mail: info@apolloDisplays.com
Internet: www.apolloDisplays.com