



OUR GLOBAL
COMPETENCE
CENTRES

 APOLLO DISPLAY
TECHNOLOGIES



 DISTEC



 DISPLAY
TECHNOLOGY



Datasheet

Diamond Systems

EPS-8130

Managed 8-Port Gigabit Ethernet switch with embedded layer 2 software



The information contained in this document has been carefully researched and is, to the best of our knowledge, accurate. However, we assume no liability for any product failures or damages, immediate or consequential, resulting from the use of the information provided herein. Our products are not intended for use in systems in which failures of product could result in personal injury. All trademarks mentioned herein are property of their respective owners. All specifications are subject to change without notice.

EPS-8130 Managed 8-Port Gigabit Ethernet switch with embedded layer 2 software

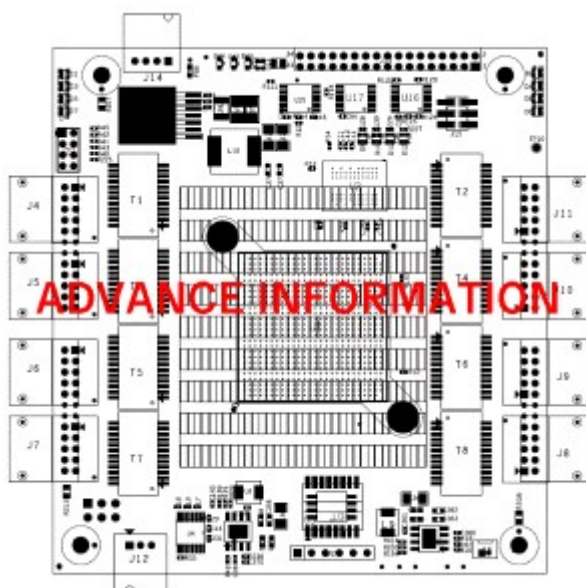

Heat spreader model EPS-8130-XT

◆ Description

Epsilon-8130 is a managed Layer 2+ Ethernet switch module offering eight 10/100/1000Mbps copper twisted pair ports in the compact PC/104 form factor. It is designed for rugged applications including industrial, on-vehicle and military. EPS-8130 is a direct replacement for the previous EPS-8100 and is fully backwards compatible with the previous product in all key respects.

Epsilon-8130 is a standalone switch that does not require any host computer interface. All switch functions are managed by a 416MHz MIPS processor embedded directly into the switch. The processor is accessed via an in-band web interface over one of the Ethernet ports or via an out-of-band command-line interface over an RS-232 serial port. The integrated web interface provides an intuitive GUI for use in configuring and managing all switch functionality. On-board memory holds

FEATURES

8 Gigabit Ethernet ports with non-blocking wire-speed performance

Built-in 416MHz MIPS 24KEC microcontroller for configuration and management

RS-232 serial port provides out-of-band management interface

Can operate autonomously or in conjunction with a host SBC

8K MAC addresses and 4K VLANs (IEEE 802.1Q), as well as 8K IPv4 and IPv6 multicast group support

Jumbo frame support at all speeds

Dual leaky bucket policers with remarking and statistics

Flexible link aggregation support based on Layer-2 through Layer-4 information (IEEE 802.3ad)

Multicast and broadcast storm control, as well as flooding control

Rapid Spanning Tree protocol (RSTP) and MSTP

8 priorities and 8 QoS queues per port with scheduling

Shaping/policing per queue and per port

Multiple protocol support: IEEE 802.1d, IEEE 802.1w, IEEE 802.1s, and IEEE 802.1X

Wide input voltage range: +5-36VDC

Latching connectors for improved ruggedness

PC/104 form factor module (90 x 96mm)

Extremely rugged -40°C to +85°C operating temperature

dual application images, boot code, MAC addresses, and other parameters, and can also be used for program execution.

Epsilon-8130's advanced Ethernet switch chip includes two innovative features that enable automatic power savings. The switch can detect unused Ethernet ports on network devices and power them down or place them in stand-by mode. Additionally, the switch actively adjusts the power level needed based on cable length, saving energy on links shorter than the 100m maximum specified length.

Epsilon-8130 was designed for use in vehicle and harsh environment applications. All I/O connectors are latching, providing enhanced reliability over the RJ-45 connectors used in commercial Ethernet switches. The wide range 5-36V input power supply is compatible with all common vehicle and industrial power sources. The -40°C to +85°C operating range makes Epsilon-8130 suitable for use in outdoor and vehicle applications.

Epsilon-8130 comes loaded with all required firmware, enabling its immediate operation without any development effort. The included web interface provides an intuitive GUI for use in configuring and managing switch functionality.

◆ Block Diagram

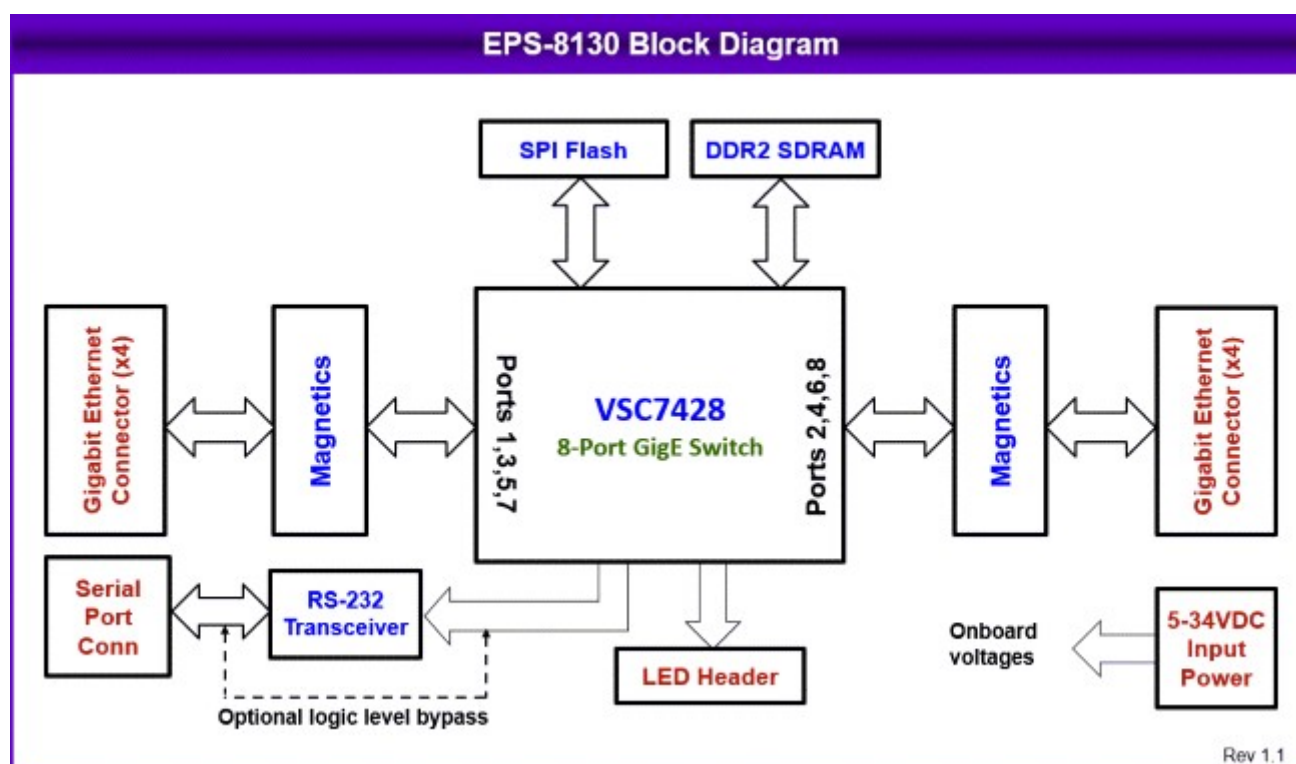

◆ Cable Kit

cable kit C-EPS8000-KIT includes all cables needed for the EPS-81xx series of Ethernet switches.

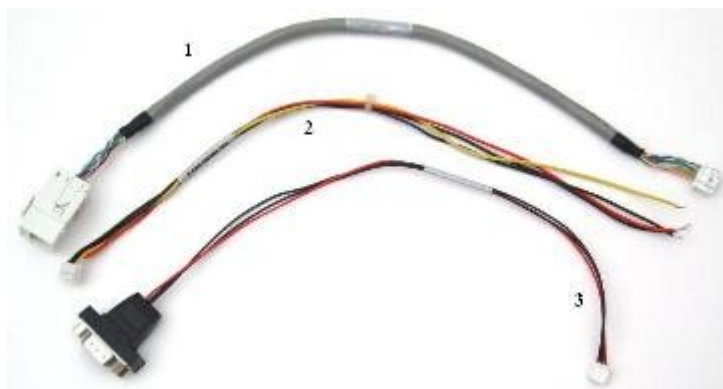

C-EPS8000-KIT includes the following cables:

No.	Qty	Cable	Description	Drawing
-----	-----	-------	-------------	---------

1	8	6981052	Ethernet cable	Show
2	1	6981051	Power cable	Show
3	1	6981050	Serial Cable, 1x3 2mm to DB9M	Show

◆ Specifications

Managed Ethernet Switch

Switch Type	Managed Layer 2+ switch Built-in MIPS 416MHz 24KEC microcontroller for configuration and management
Number of Ports	8 10/100/1000Mbps Ethernet ports with non-blocking wire-speed performance
On-board Memory	4Mb packet memory Shared memory buffer with per-port & CoS memory management
MEF	Hierarchical MEF compliant policing & scheduling MEF E-Lane, E-Line, and E-Tree services
Frame Buffer	Jumbo frame support at all speeds
VLAN	IEEE 802.1Q VLAN switch with 8K MACs and 4K VLANs Push/pop up to two VLAN tags Independent & shared VLAN learning (IVL, SVL)
Multicast	IPv4 and IPv6 multicast group support
Remarking	Dual leaky bucket policers with remarking and statistics
Classifier	8 priorities and 8 CoS queues per port with strict or deficit-weighted round robin scheduling Shaping/policing per queue and per port
Storm Control	Policing with storm control and MC/BC protection
Link Aggregation	IEEE 802.3ad
Security	Advanced security and prioritization available through multistage TCAM engine
RSTP	Rapid Spanning Tree Protocol (IEEE 802.1W) and MSTP
MIBs	Support for both WebStax and CEServices MIBs
Power Management	ActiPHY and PerfectReach power management VeriPHY cable diagnostics
Serial Port	1 RS-232 port for host interface
Indicator LEDs	18 status LEDs, two per port 2 general purpose
Standalone Capable	Standalone network switch, or in combination with a host computer
General	
Power Input	+5 to +36V DC/DC power supply
Power Consumption	5.4W typical at +5VDC
Form Factor / Dimensions	PC/104 3.55" x 3.775" (90mm x 96mm)
Operating Temperature	-40°C to +85°C (-40°F to +185°F)
Weight	3.5oz (99g) with heatsink
MTBF	624,170 hours at 20°C
RoHS	Compliant

◆ Models and Accessories

EPS-8130

available models:

EPS-8130	8-Port Gigabit Ethernet Switch, Layer 2 Embedded Software, Latching Connectors, -40/+85C, Heat Sink
EPS-8130-XT	8-Port Gigabit Ethernet Switch, Layer 2 Embedded Software, Latching Connectors, -40/+85C, Heat Spreader

Please [login](#) or [signup](#) for an online quote request.

Cables and accessories

available models:

C-EPS8000-KIT Epsilon-8000/8100/8130 Cable Kit: Ethernet (8), power, and serial cables

6981052 Ethernet cable

6981051 Power cable

6981050 Serial Cable, 1x3 2mm to DB9M

Please [login](#) or [signup](#) for an online quote request.

www.diamondsystems.com | [Sunnyvale, California USA](#) | [+1-650-810-2500](tel:+16508102500) | sales@diamondsystems.com

Our company network supports you worldwide with offices in Germany, Austria, Switzerland, the UK and the USA. For more information please contact:

Headquarters

Germany



FORTEC Elektronik AG

Augsburger Str. 2b
82110 Germering

Phone: +49 89 894450-0
E-Mail: info@fortecaq.de
Internet: www.fortecaq.de

Fortec Group Members

Austria



Distec GmbH Office Vienna

Nuschinggasse 12
1230 Wien

Phone: +43 1 8673492-0
E-Mail: info@distec.de
Internet: www.distec.de

Germany



Distec GmbH

Augsburger Str. 2b
82110 Germering

Phone: +49 89 894363-0
E-Mail: info@distec.de
Internet: www.distec.de

Switzerland



ALTRAC AG

Bahnhofstraße 3
5436 Würenlos

Phone: +41 44 7446111
E-Mail: info@altrac.ch
Internet: www.altrac.ch

United Kingdom



Display Technology Ltd.

Osprey House, 1 Osprey Court
Hinchingsbrooke Business Park
Huntingdon, Cambridgeshire, PE29 6FN

Phone: +44 1480 411600
E-Mail: info@displaytechnology.co.uk
Internet: www.displaytechnology.co.uk

USA



Apollo Display Technologies, Corp.

87 Raynor Avenue, Unit 1
Ronkonkoma, NY 11779

Phone: +1 631 5804360
E-Mail: info@apolloDisplays.com
Internet: www.apolloDisplays.com