



OUR GLOBAL
COMPETENCE
CENTRES

 APOLLO DISPLAY
TECHNOLOGIES



 DISTEC



 DISPLAY
TECHNOLOGY



Datasheet

Diamond Systems

EPSM-10GX

Ultra-Compact Managed 26-Port Gigabit Ethernet Switch Module



The information contained in this document has been carefully researched and is, to the best of our knowledge, accurate. However, we assume no liability for any product failures or damages, immediate or consequential, resulting from the use of the information provided herein. Our products are not intended for use in systems in which failures of product could result in personal injury. All trademarks mentioned herein are property of their respective owners. All specifications are subject to change without notice.

EPSM-10GX EPSM-10GX Ultra-Compact Managed 26-Port Gigabit Ethernet Switch Module

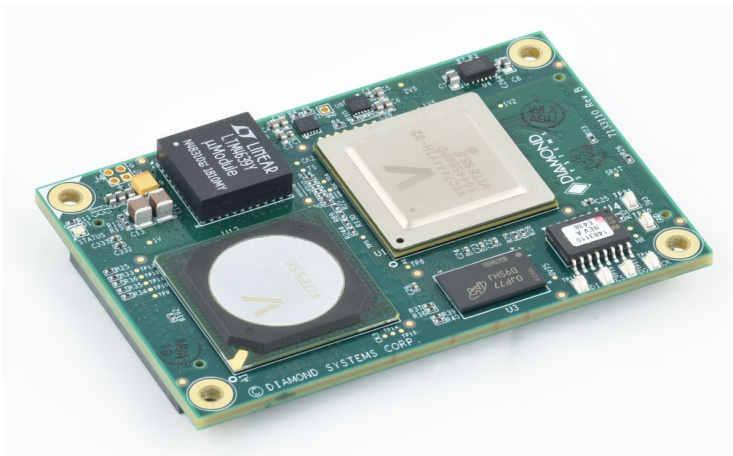

EPSM-10GX Ethernet Switch Module

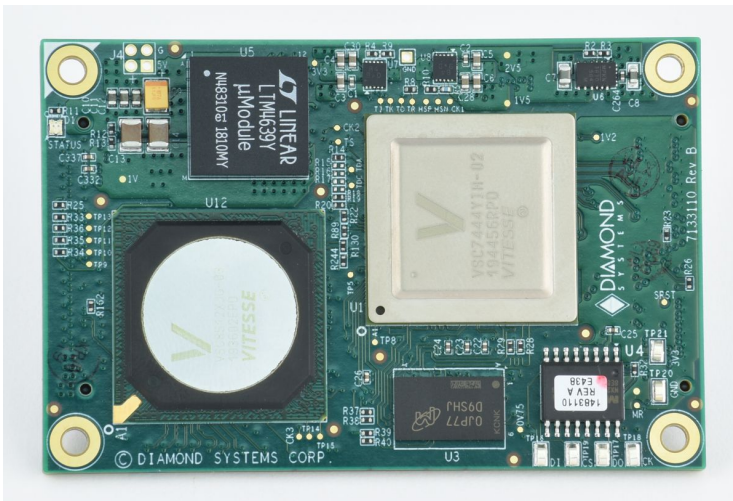

EPSM-10GX top view

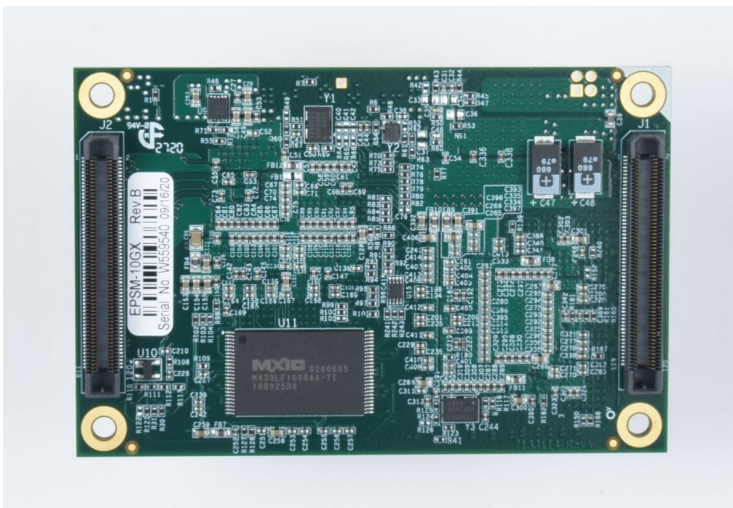

FEATURES

COM-like virtually-complete Ethernet switch with embedded software on a compact module

Enables rapid development of custom Ethernet switch boards and systems

Only magnetics, connectors, and input voltage regulator needed to create complete solution

24 total gigabit Ethernet ports – 12 from on-board PHY, 12 from carrier board PHY

2 10G SFI ports for SFP+ or rugged optical transceivers

High speed connectors carry all signals to carrier board

Only 55 x 84mm / 2.2 x 3.3", same size as a business card

Thicker PCB and -40 to +85°C operating temperature support rugged mobile applications

Heat sink and heat spreader thermal solutions and design files available

Layer 2+ switching and Layer 3 routing software available

IEEE 1588 PTP support available

Design kit available with carrier board schematics and bill of materials

Custom carrier board and complete switch solution design and manufacturing services available

EPSM-10GX bottom view

◆ Description

The EPSM-10GX is a managed Ethernet switch module in an ultra-compact 2.2" x 3.3" (55 x 84mm) size offering 24 10/100/1000Mbps copper ports + 2 10Gbps SFI ports. The core Ethernet switching technology is almost fully encapsulated on the module; for many applications, only the "last inch" of magnetics and I/O connectors is required to complete the circuit, enabling easy development of custom form factor compact, rugged Ethernet switch solutions.

The small size, based on the industry-standard COM Express Mini form factor, makes EPSM-10GX a perfect choice for use as a building block for creating custom Ethernet switch solutions in a variety of space-demanding applications, such as drones, ground and underwater vehicles, and robots.

Two software packages are available, Layer 2+ switching and Layer 3 routing/switching. In addition, IEEE-1588 precision time protocol support is available with a minor modification to support an external precision clock circuit and 1pps signal source provided by the carrier board. All software features are manageable via a GUI web interface accessible over any port, as well as with a command language accessed via a built-in RS-232 port.

Two cooling accessory options are available: A heat sink provides convection cooling in a low profile, while a heat spreader provides improved conduction cooling for superior high temperature performance in applications where physical contact with the system enclosure is available.

Two high-speed fine-pitch connectors provide all power and data communications between the module and the carrier board. The first connector provides power, 9 10/100/1000 ports, the serial interface, and a serial LED data stream. Applications requiring 9 ports or less may use just this connector. The second connector contains 3 more 10/100/1000 ports, QSGMII signals for an additional 12-port PHY to provide 12 additional 10/100/1000 ports, and the 2 10G SFI ports.

EPSM-10GX is designed to meet the challenges of vehicle environments with its 50% thicker PCB, -40/+85°C operating temperature range, and MIL-STD-202G shock/vibration resistance.

◆ Block Diagram

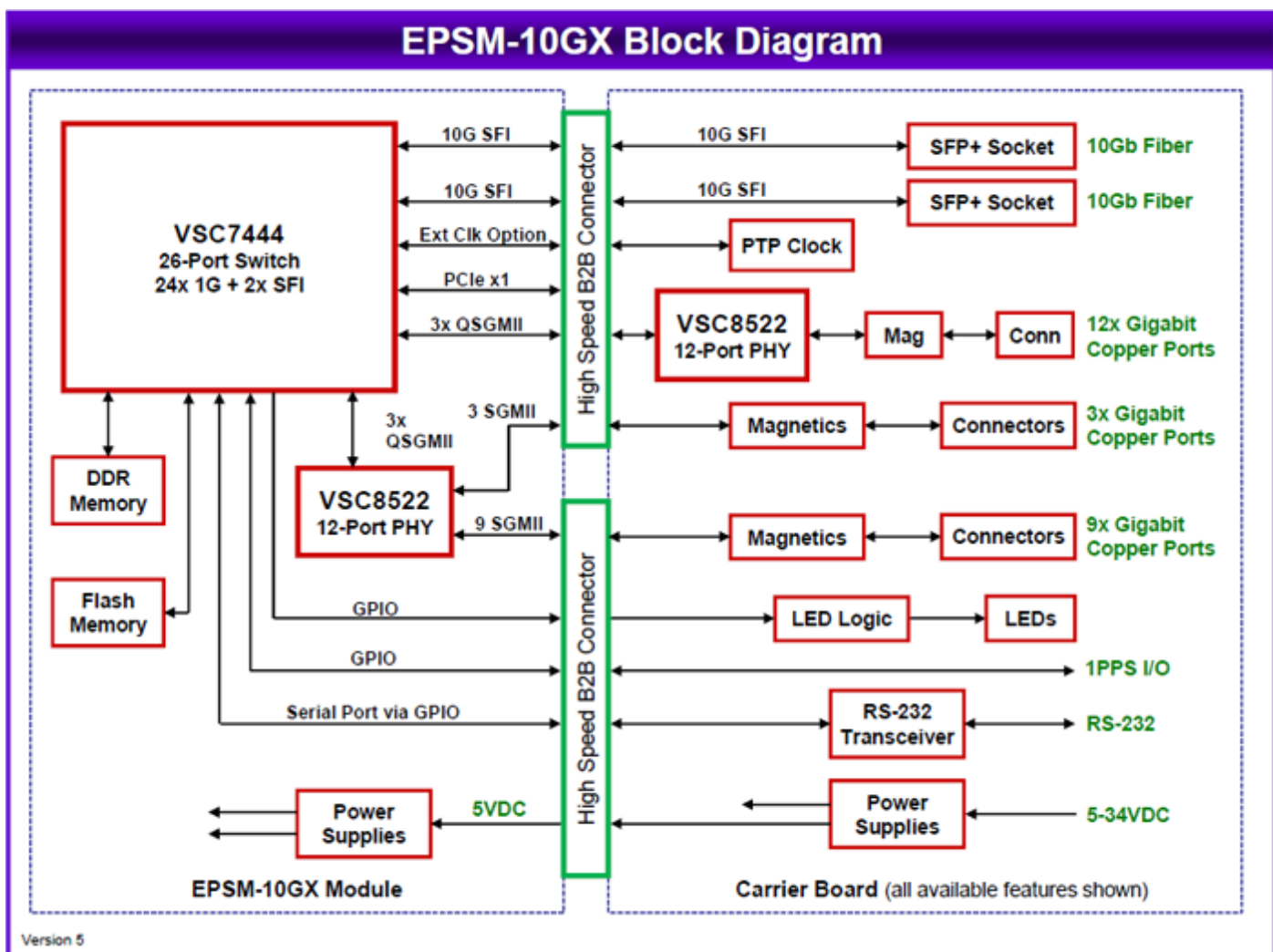

◆ Embedded Software

Two software packages are available for EPISM-10GX, Layer 2+ switching and Layer 3 routing/switching. In addition, IEEE-1588 precision time protocol support is available with a minor modification to support an external precision clock circuit and 1pps signal source provided by the carrier board. All software features are manageable via a GUI web interface accessible over any port, as well as with a command language accessed via a built-in RS-232 port.

The table below shows some of the more popular features available. For a complete list of features available in each software package, [click here](#).

Layer 2+ software highlights include the following:

8K MAC addresses and 4K VLANs (IEEE 802.1Q)

8K IPv4 and IPv6 multicast group support

Jumbo frame support at all speeds

Flexible link aggregation support based on Layer-2 through Layer-4 information (IEEE 802.3ad)

Multicast and broadcast storm control, as well as flooding control

Rapid Spanning Tree protocol (RSTP) and MSTP

Multiple protocol support: IEEE 802.1d, IEEE 802.1w, IEEE 802.1s, and IEEE 802.1X

8 priorities and 8 QoS queues per port with scheduling

Layer3 software additional highlights:

Hardware- and software-based IPv6 L3 static routing

RFC 2328 OSPFv2 dynamic routing

IEEE 1588 precision time protocol (PTP)

RADIUS accounting

Port and Queue policers

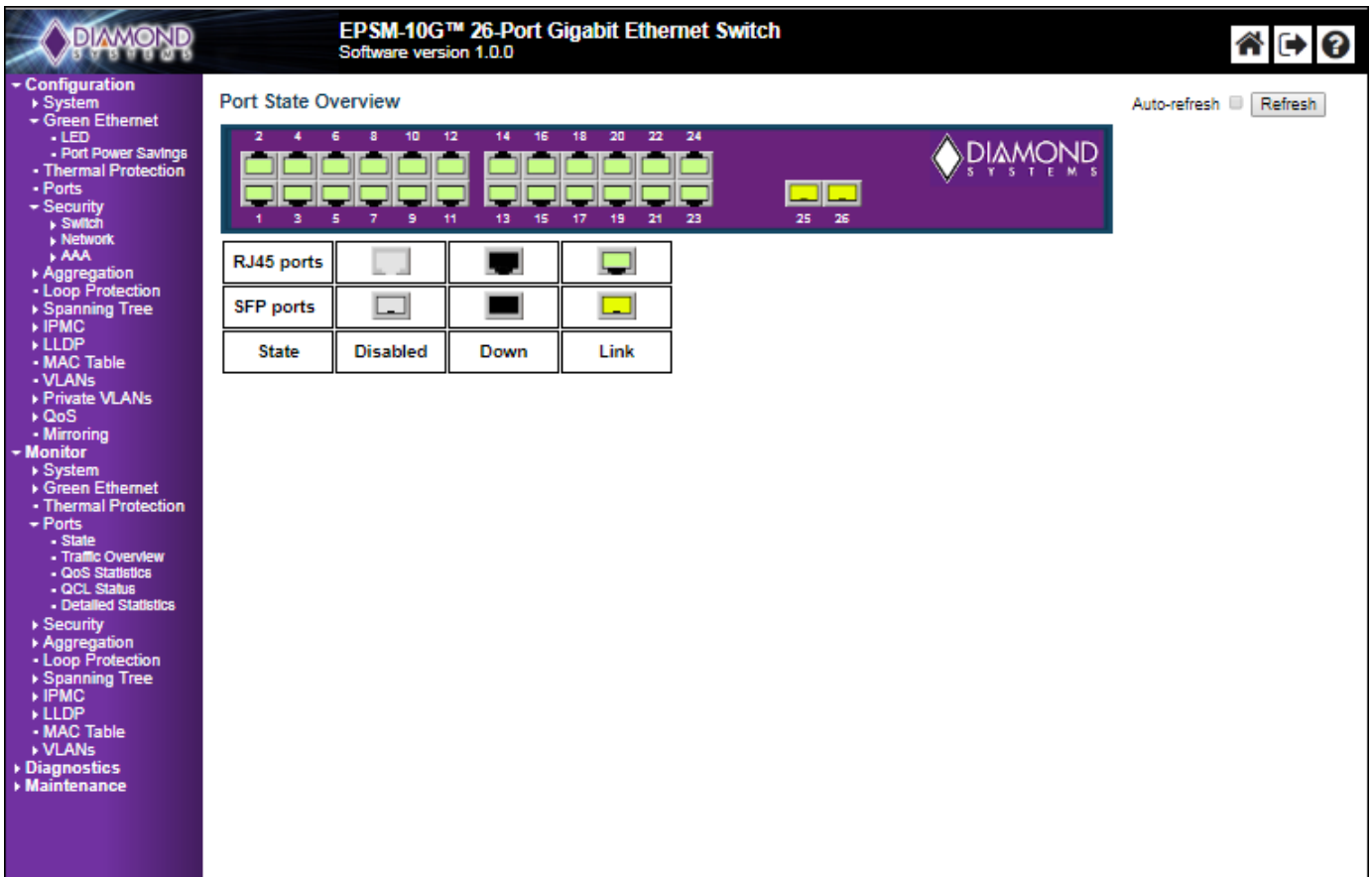

◆ Cooling Options

Both heat sink and heat spreader cooling options are available. The heat spreader is the preferred choice for applications where the packaging design permits its use. It includes an integrated thermal pad for improved contact with the enclosure wall. For customer's designing their own cooling solutions, Diamond can provide 3D files and other design support./p>

◆ Development Support

A design guide is available with circuit details and other technical information necessary to design a carrier board around the EP5M-10GX. A complete development kit is also available including the technical design package (schematics, PCB layout, and BOM) of our EPS-24G4X carrier board, along with a complete EPS-24G4X switch and cable kit. Contact Diamond Systems for further information and ordering instructions.

◆ Custom Carrier Board Design

Diamond Systems engages in the design and manufacturing of of custom carrier boards for various computing technologies, including COM Express, Nvidia Jetson GPU modules, and Ethernet switch modules. Contact us to learn more about how we can provide a cost-effective, low-risk, quick time to market solution for your Ethernet switch project using the EP5M-10GX switch module and a custom carrier board that fits your exact needs.

◆ Specifications

Number of Ports	24 10/100/1000Mbps Ethernet ports with non-blocking wire-speed performance 2 10G SFI ports for fiber or copper transceivers Magnetics and 10G transceivers required on carrier board
Implementation	12 PHYs integrated on main board; QSGMII signals for additional 12-port PHY on carrier board
On-board Memory	4MB packet memory
Network Management	SNMP v1/v2c/v3; Web GUI and command line interface (CLI)
Power Management	ActiPHY and PerfectReach power management reduce power for shorter cable lengths and shut down power to disconnected ports
Serial Port	1 serial port for host interface; RS-232 transceiver required on carrier board

Indicator lights	Serial data stream provided for 2 LEDs per port; decoder logic required on carrier board
Form Factor	55x84mm / 2.17x3.31" (Same as COM Express Type 10)
Interconnect	Dual Samtec ERF5 series connectors, 120 pins each, 10mm board to board spacing
Input voltage	5VDC +/-5%
Power consumption	20W max, all ports active
Operating temperature	-40 to +85°C with DSC-provided heat sink or heat spreader
Cooling	Heat sink, 55x84mm, 16.6mm height Heat spreader, 55x104mm, 7.6mm height
Weight	85G / 3.0 oz
Rohs	Compliant

◆ Ordering Information

◆ Models and Accessories

EPISM-10GX

available models:

EPISM-10GX	Compact 26-port gigabit ethernet switch module with embedded Layer 2 switching software	NRND
EPISM-10GX-L3	Compact 26-port gigabit ethernet switch module with embedded Layer 3 routing/switching software	NRND
EPISM-10GX-1588	Compact 26-port gigabit ethernet switch module with embedded Layer 3 routing/switching software, configured for external PTP clock	EOL
DK-EPISM10GX-01	EPISM-10GX carrier board design kit, includes EPISM-10GX with Layer 2 software, carrier board, cable kit, and design files (NDA required)	EOL

Please [login](#) or [signup](#) for an online quote request.

www.diamondsystems.com | [Sunnyvale, California USA](#) | [+1-650-810-2500](tel:+16508102500) | sales@diamondsystems.com

Our company network supports you worldwide with offices in Germany, Austria, Switzerland, the UK and the USA. For more information please contact:

Headquarters

Germany



FORTEC Elektronik AG

Augsburger Str. 2b
82110 Germering

Phone: +49 89 894450-0
E-Mail: info@fortecaq.de
Internet: www.fortecaq.de

Fortec Group Members

Austria



Distec GmbH Office Vienna

Nuschinggasse 12
1230 Wien

Phone: +43 1 8673492-0
E-Mail: info@distec.de
Internet: www.distec.de

Germany



Distec GmbH

Augsburger Str. 2b
82110 Germering

Phone: +49 89 894363-0
E-Mail: info@distec.de
Internet: www.distec.de

Switzerland



ALTRAC AG

Bahnhofstraße 3
5436 Würenlos

Phone: +41 44 7446111
E-Mail: info@altrac.ch
Internet: www.altrac.ch

United Kingdom



Display Technology Ltd.

Osprey House, 1 Osprey Court
Hinchingsbrooke Business Park
Huntingdon, Cambridgeshire, PE29 6FN

Phone: +44 1480 411600
E-Mail: info@displaytechnology.co.uk
Internet: www.displaytechnology.co.uk

USA



Apollo Display Technologies, Corp.

87 Raynor Avenue, Unit 1
Ronkonkoma, NY 11779

Phone: +1 631 5804360
E-Mail: info@apolloDisplays.com
Internet: www.apolloDisplays.com