

# Manual

## FORTEC Integrated

FP32-RLA, FP43-RLA, FP55-RLA,  
FP65-RLA, FP75-RLA, FP85-RLA

350nits Android SoC Capacitive Touch Free Standing



**FORTEC**  
UNITED STATES



**FORTEC**  
INTEGRATED



**FORTEC**  
UNITED KINGDOM



---

The information contained in this document has been carefully researched and is, to the best of our knowledge, accurate. However, we assume no liability for any product failures or damages, immediate or consequential, resulting from the use of the information provided herein. Our products are not intended for use in systems in which failures of product could result in personal injury. All trademarks mentioned herein are property of their respective owners. All specifications are subject to change without notice.

---

# User Manual

## Applicable models:

FE27E-RLA/M	FI27E-RLA/M	FP27E-RLA/M
FE32E-RLA/M	FI32E-RLA/M	FP32E-RLA/M
FE43E-RLA/M	FI43E-RLA/M	FP43E-RLA/M
FE49E-RLA/M	FI49E-RLA/M	FP49E-RLA/M
FE55E-RLA/M	FI55E-RLA/M	FP55E-RLA/M
FE65E-RLA/M	FI65E-RLA/M	FP65E-RLA/M
FE75E-RLA/M	FI75E-RLA/M	
FE85E-RLA/M	FI85E-RLA/M	

 Before using this product, please read the user manual carefully and properly keep it for future reference.

# Contents

---

Warning and Precautions .....	1-4
Features .....	5
Accessories .....	6
Exterior Components.....	7
Installation Instructions.....	8
Troubleshooting .....	9

---

## Warning and Precautions

Electricity can provide many useful functions, but improper use will also cause harm to personal and property security, both the design and manufacturing of this product are based on the highest requirements of safety, improper use may cause harm, such as electric shock, fire damage, etc. To avoid such dangerous, please comply with the following instructions when users are installing, operating and cleaning. In order to ensure your personal safety and prolong the service life of the product, please read carefully before start using safety warning clause.

1. Read this instruction  
Before operating the unit, please read and understand all instructions.
2. Keep this instruction  
Please store this safety and operation instruction in safe place for future use.
3. Heed all warnings  
Please strictly abide by all the safety warning related to this product in this manual.
4. Follow the instruction  
Please follow all instructions
5. Accessories  
Please use the attachments or accessories designated by manufacturer. Do not utilize the accessories recommended by illegal manufacturer, otherwise may cause accident.
6. Power supply  
The power supply utilized in this unit is marked on the power supply label. If you are not sure the power supply type in your area, please consult the local dealer or electric power company. To better protect the product, in the thunderstorm weather or when this unit is not utilized for a long time or when unattended for a long time, please unplug the power plug of this unit and disconnect the antenna, which will help to protect the product from damaged by lightning or power cord surging. When need to utilize this unit with another type of power supply, please replace the power cord and consult to local dealer. Power outlet shall be installed in the place where is easy to connect and close to the unit. Please utilize the power cord designated by the dealer to ensure the safety and electromagnetic compatibility.  
When the unit is needed to connect with VCR or computer, please turn off the power supply of this unit to avoid electric shock.
7. Power cord protection  
Please protect the power cord, especially the connection position among plug, socket and power cord with this unit should not be trampled.
8. Overload  
As for the wall socket and power outlet, do not overload use, to avoid fire or electric shock.
9. Objects fell into or liquid splashed into  
Don't insert objects from the ventilation hole or the hole of this unit. This unit has high pressure, the inserted object may cause electric shock or parts short circuit inside the unit.  
So don't let water drop or liquid spill into the unit.
10. Maintenance  
Please contact maintenance issues to the authorized service personnel. When the unit is damaged by the followings, the unit is needed to be repaired: the power cord or power plug is damaged; liquid splashed into or solid fell into the unit, the unit is exposed to the rain or damp environment or the unit is dropped.

## Warning and Precautions

### 11. Conditions requiring maintenance

When any of the following conditions occurs, please pull the plug from the AC socket and contact the professional maintenance personnel for repair.

- Power cord or plug damages;
- When liquid splashed into or solid fell into;
- When the unit is exposed in rain or water;
- When do not operate according to the instructions described in the operation manual; do not carry out operation not regulated in operation manual, improper adjustment or setting may cause damage to the unit, at this time, it needs rectification or adjustment by professional technical personnel.
- When the unit falls or the case has any damage;
- When the unit displays abnormal conditions or significant changes, which indicates that the unit needs to be repaired.

### 12. Replace parts.

When the product's parts need to be replaced, please confirm that the parts utilized by maintenance personnel is designated by manufacturer, or original parts with same characteristics and performance. Usage of unlicensed parts may cause fire, shock and/or other hazards.

### 13. Safety inspection

When maintenance service is completed, please ask maintenance personnel to check safety performance of unit to confirm that the unit is under normal state.

### 14. Wall hanging

When the unit needs to be hung on wall or ceiling, please make sure to install according to the method provided by the manufacturer. This concerns safety issues.

### 15. Holder

Please utilize the wheelbarrow, foot rest, tripod, holder or table designated by manufacturer or sold with the unit. Do not place it on unstable trolley, holder, tripod or table. Placing the unit on unstable surface may cause the unit to fall and injure personnel or damage the product. Please follow the manufacturer's installation instructions when it needs to be hung on wall. Please utilize the wall accessories recommended by manufacturer.

### 16. Move carefully

When moving with small car, please be careful to move the cart and the unit to avoid the fall of the unit and injuring personnel.

Sudden stop, excessive force and uneven ground may cause the unit to fall from the cart.

Do not utilize and move LCD Unit at work or standby mode.

### 17. Lightning strike

Please unplug the battery socket of the unit when the unit is not utilized for a long time or in thunderstorm weather.

For better protection of this product, please unplug the battery socket of the unit and disconnect the antenna in thunderstorm weather or when the unit is not utilized for a long time or unattended for a long time. This will help to prevent the damage to the product caused by lightning or online surge.

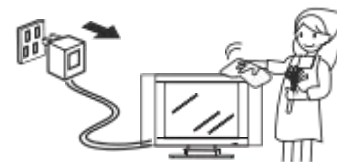

## Warning and Precautions

18. Please do not utilize this unit near water source.  
For example, near the tub, wash basin, kitchen sink or wash basin; in a wet ground or near a swimming pool, etc.  
When moving the unit from a low temperature place to a high temperature place, water steam will be condensed, do not utilize in this case, otherwise it may cause fire, electric shock or other hazards.
19. Please clean with dry cloth.  
Please remove the power cord before cleaning, do not utilize liquid cleanser or aerosol to clean this unit. Please utilize dry cloth when cleaning.
20. Ventilation opening  
Please do not block any open ventilation hole. Please install the unit according to manufacturer's instruction. Both opening and ventilation holes in the unit casing are designed for ventilation. Do not plug these opening and ventilation holes. Insufficient ventilation may lead to overheating and may shorten the service life of the unit.  
Please do not place the unit on bed, sofa, carpet or other similar surface, because this will block the heat emission opening. This product design does not support embedded installation, unless there is adequate ventilation space or permitted in the manual by manufacturer, please do not install the unit in confined space, such as bookcases, shelf, etc.
21. Heat source  
Do not install the unit near heat source such as heater, stove or other heating equipments (including efficacy).
22. Screen protection  
The LCD screen is made of glass.  
Therefore, the screen may be broken when the unit falls or it is compressed by other objects. Be careful to avoid damage when the screen is broken.
23. Pixel defects  
The LCD screen of this unit is a high-tech product, it can provide fine picture. Sometimes, some inactive pixels may appear blue, green or red fixed point on the screen, but that does not affect its performance.

**Remarks: when utilizing this product, the product's power plug must be connected to the power supply outlet with protective grounding.**

### Temperature



Do not store or utilize the unit in places where temperature is too low or too high.

When the unit is utilized in a place where temperature is too low temperature, the picture may have streak or slightly slower reaction or other phenomenon, which do not belong to defect in the performance of the unit. When the temperature returns to normal, the unit will return to normal.

Please do not store the unit in a place where temperature is too low or too high. Please do not place it in direct sunlight or near heat source.

The storage temperature range of this unit: **-20°C to + 60°C**

Working temperature range: 0°C to + 50°C

	AC voltage: This symbol indicates that the rated voltage marked with the symbol is AC voltage.
	Class II product : This symbol indicates that it does not require a safety connection of protective earthing (ground).
	The lightning flash with arrowhead symbol, within an equilateral triangle is intended to alert the user to the presence of uninsulated dangerous voltage within the product's enclosure that may be of sufficient magnitude to constitute a risk of electric shock.

## Warning and Precautions

### Image tail

Picture permanently stay on screen caused by solid state (non-dynamic) images staying on the LCD screen for a long time is not the performance defect of this unit, therefore it is not in the range of warranty. When utilizing this unit, please do not keep the picture to stay on screen for a long time.

Please note the following important information when the unit is utilized with a game console, computer or other external device that can output solid state image.

Picture staying on LCD screen for a long time may cause permanent shadow picture.

So when you watch other LCD Unit programs, the shadow image will be displayed on the screen in static fixed background. To alleviate this phenomenon, you shall follow the following steps:

- A. Minimize brightness/contrast in visual range.
- B. Don't display solid images for a long time.
- C. Please turn off the unit when do not use it.

### Cleaning and maintenance

Please clean and wipe the unit with soft dry cloth.

If it cannot be wiped clean with soft dry cloth, can utilize this cloth to dip moderate amount of soapy water or weak cleaner to wipe this unit.

Utilize the cleaning tool for wiping lens to wipe the dirt off the screen.

Do not utilize alcohol, paint thinner or gasoline to wipe the unit.

Before cleaning the unit with cleaning cloth after treated by chemical processing, Please read the instructions of cleaning cloth carefully.

## Features

- 1.RK 3288,Cortex-A17@1.8GHz, Android 9.0
- 2.LCD F/UHD panel
- 3.Resolution:3840\*2160 (75~85) ,1920\*1080 (27~65inch)
- 4.RAM 2GB; Internal memory 16GB
- 5.2\*10W Speaker
- 6.Support HDMI 、 USB、 RJ45 interface
- 7.Tempered glass protection
- 8.AC 100~240V 50/60Hz

Note: The picture is for reference only, please refer to the actual product



# Accessories

Please make sure the following items are included with your LCD Unit. If any items are missing, please contact your dealer.

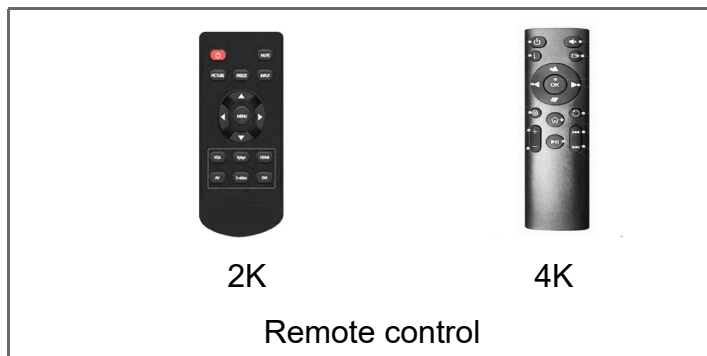
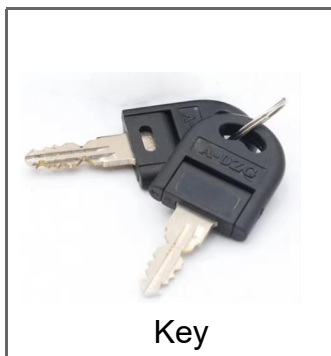
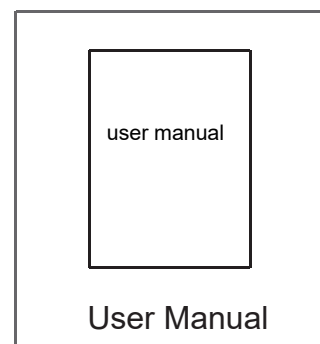
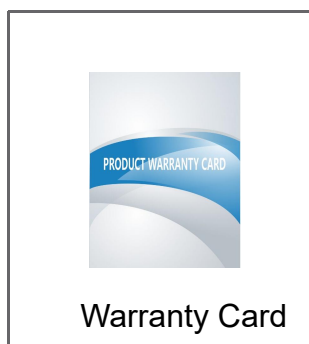
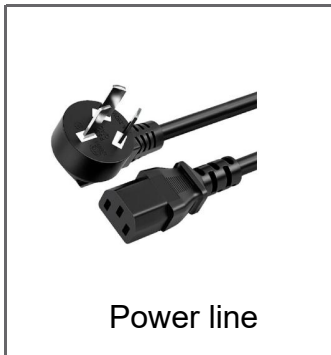
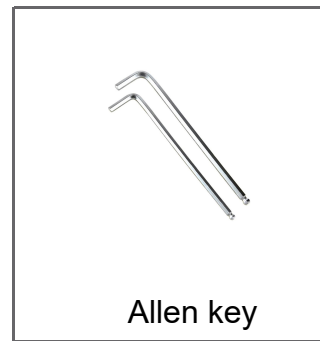
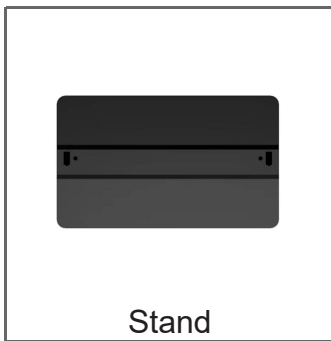
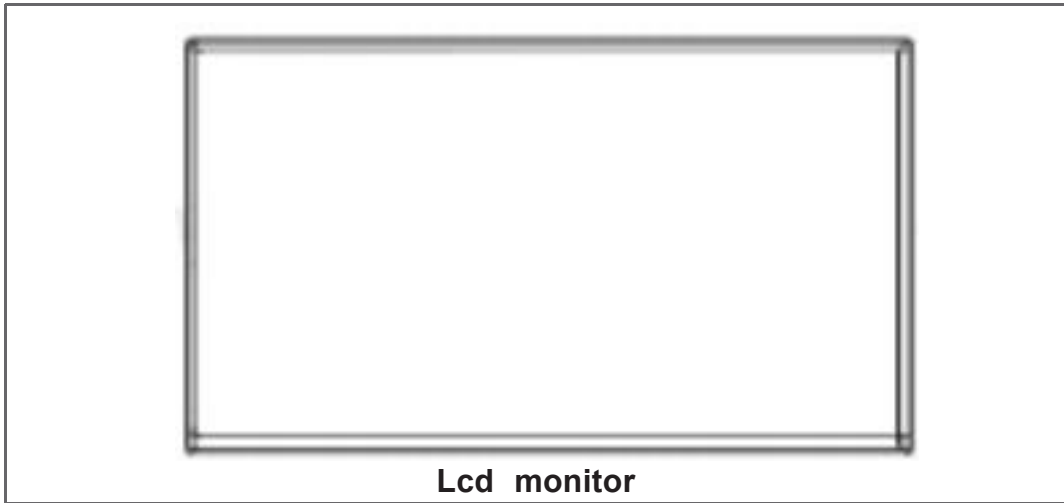

Note: The picture is for reference only, please refer to the actual product

## Exterior Components

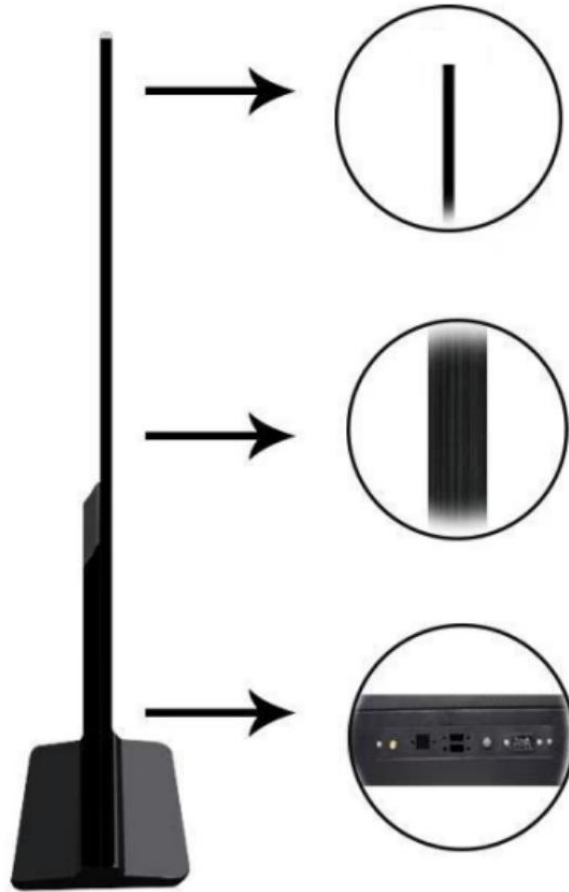

### Android Solution Interface

Interface	Funcation	Remark
USB*2	Read U disk	/
HDMI IN*1	Support external HDMI IN signal source input	/
RJ45*1	Support limited network input	/
WIFI*1	Support wireless network connection	/
ON/OFF*1	AC power switch	/
Power*1	AC voltage input	/

### Monitor Solution Interface

Interface	Funcation	Remark
USB*2	Read U disk	Reserved cable interface
HDMI IN*1	Support external HDMI IN signal source	/
RJ45*1	Support limited network input	Reserved cable interface
Touch USB	Support HDMI in touch	No touch, cancel this interface
ON/OFF*1	AC power switch	/
Power*1	AC voltage input	/

## Installation Instructions

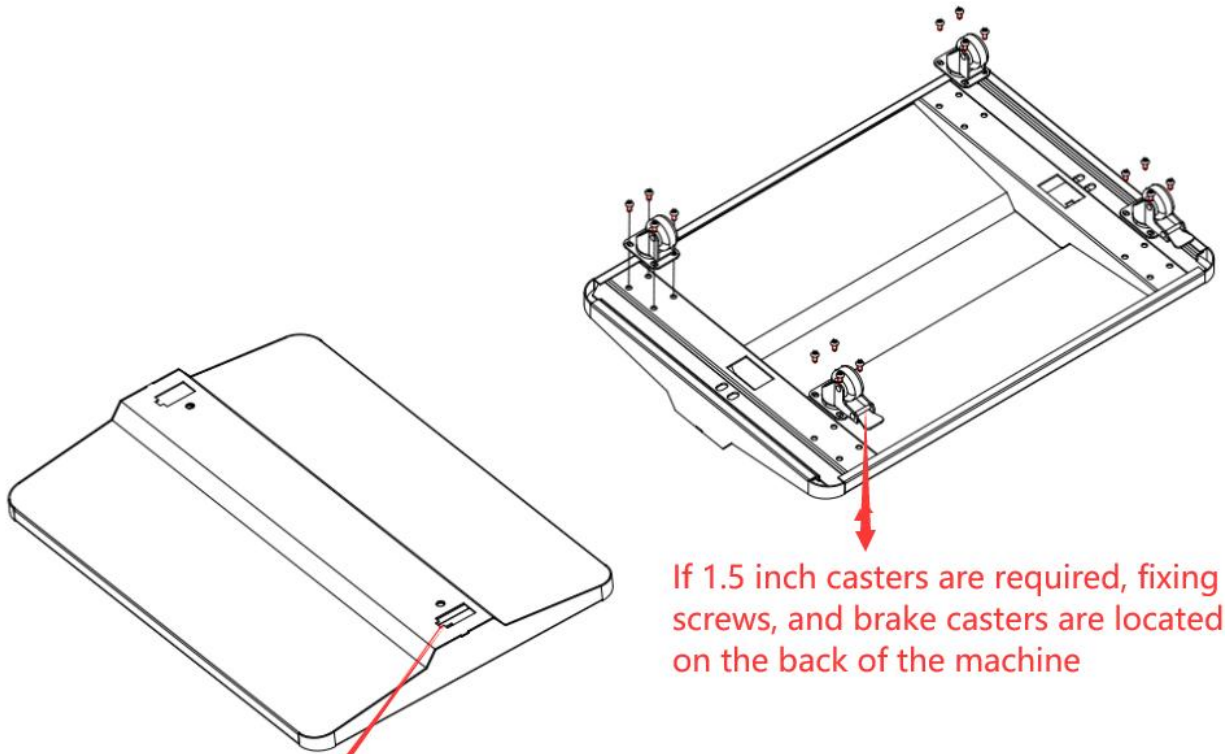

If 1.5 inch casters are required, fixing screws, and brake casters are located on the back of the machine

The gap is on the front of the machine

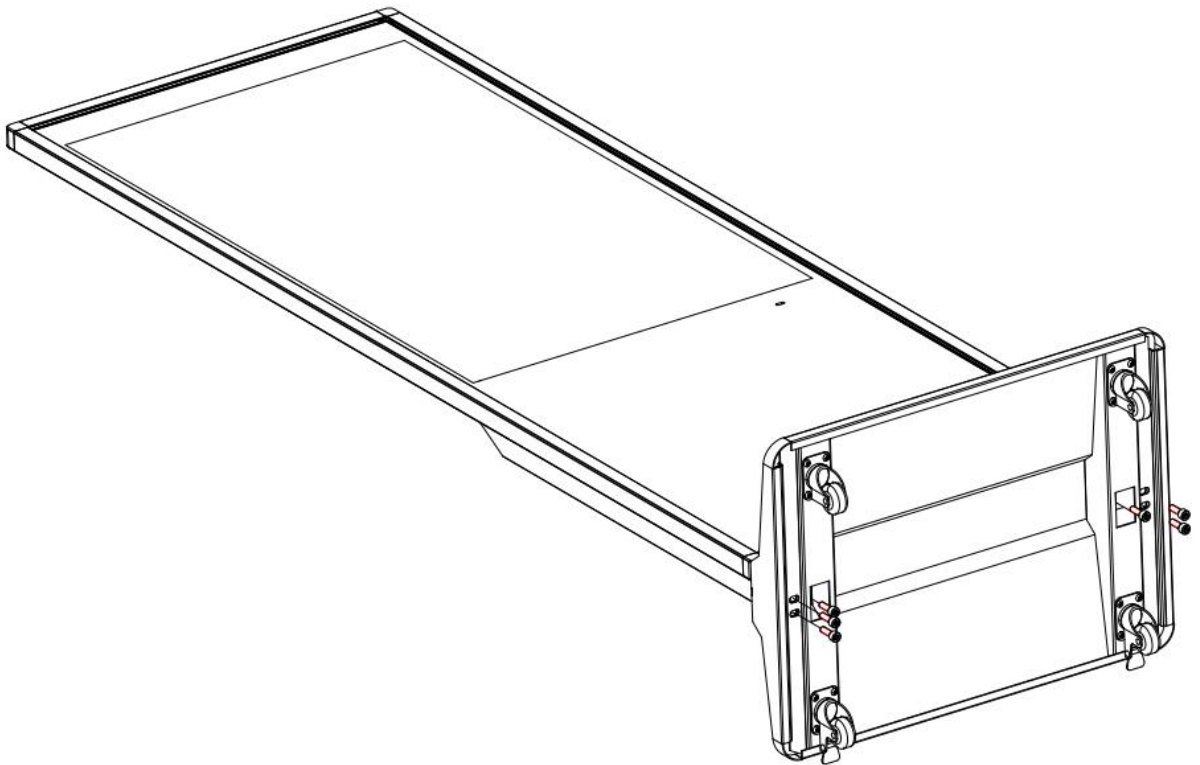

Insert the corresponding gap of the machine and fix the M8 hexagon socket head screw

Note: There are no wheels by default

# Troubleshooting

## No picture, no accompanying sound

---

1. Check whether the fuse and circuit breaker is working properly.
2. Insert other electrical equipments into socket to ensure the outlet is normal or opened.
3. Poor contact between power plug and socket.
4. Check the indicator .

## Blue screen in computer mode

---

1. Check the signal source.
2. Insert external HDMI input.

## No picture, accompanying sound is normal

---

1. Please check the Android menu settings.

## Picture is normal, no accompanying sound

---

1. Press the volume increase button to increase volume.
2. May be in mute State, press mute button to restore sound.
3. Change the accompanying sound mode.

## There is messy corrugation on the picture

---

Usually it caused by local interference, such as automobiles, fluorescent lamps, hair dryers and so on. Adjust the antenna to minimize interference.

## Network not working or slow

---

1. Check if the Android menu network is connected properly.
2. Check if the WiFi stick is connected

## USB not working

---

1. Check if the extension is connected properly.
2. Check if the Android motherboard interface is functioning properly
3. Check if the Android menu install.

## menu time is Incorrect

---

1. Automatic update time for network connection.
2. Manual adjustment of Android menu time

Note: Do not try to repair the machine by yourself at any time, please contact the local customer service center.

Our company network supports you worldwide with offices in Germany, Austria, Switzerland, the UK and the USA.  
For more information please contact:

## Headquarters

Germany



**FORTEC**  
GROUP

**FORTEC Elektronik AG**  
Augsburger Str. 2b  
82110 Germering

Phone: +49 89 894450-0  
E-Mail: [info@fortecag.de](mailto:info@fortecag.de)  
Internet: [www.fortecag.de](http://www.fortecag.de)

---

## Fortec Group Members

Austria



**FORTEC**  
INTEGRATED

**FORTEC Integrated GmbH Office Vienna**  
Nuschinggasse 12  
1230 Wien

Phone: +43 1 8673492-0  
E-Mail: [info@fortec-integrated.de](mailto:info@fortec-integrated.de)  
Internet: [www.fortec-integrated.de](http://www.fortec-integrated.de)

Germany



**FORTEC**  
INTEGRATED

**FORTEC Integrated GmbH**  
Augsburger Str. 2b  
82110 Germering

Phone: +49 89 894363-0  
E-Mail: [info@fortec-integrated.de](mailto:info@fortec-integrated.de)  
Internet: [www.fortec-integrated.de](http://www.fortec-integrated.de)

Switzerland



**FORTEC**  
SWITZERLAND

**FORTEC Switzerland AG**  
Bahnhofstraße 3  
5436 Würenlos

Phone: +41 44 7446111  
E-Mail: [info@fortec.ch](mailto:info@fortec.ch)  
Internet: [www.fortec.ch](http://www.fortec.ch)

United Kingdom



**FORTEC**  
UNITED KINGDOM

**FORTEC Technology UK Ltd.**  
Osprey House, 1 Osprey Court  
Hinchingsbrook Business Park  
Huntingdon, Cambridgeshire, PE29 6FN

Phone: +44 1480 411600  
E-Mail: [info@fortec.uk](mailto:info@fortec.uk)  
Internet: [www.fortec.uk](http://www.fortec.uk)

USA



**FORTEC**  
UNITED STATES

**FORTEC US, Corp.**  
87 Raynor Avenue, Unit 1  
Ronkonkoma, NY 11779

Phone: +1 631 5804360  
E-Mail: [info@fortec.us](mailto:info@fortec.us)  
Internet: [www.fortec.us](http://www.fortec.us)