



OUR GLOBAL
COMPETENCE
CENTRES

 APOLLO DISPLAY
TECHNOLOGIES



 DISTEC



 DISPLAY
TECHNOLOGY



Datasheet

BOE

BJ%&) : <A!B,)

ÓUËËËÍ



PRODUCT GROUP

REV

ISSUE DATE

LCM PRODUCT

P2

2019.09.06

SPEC. NUMBER

SPEC. TITLE

PAGE

NV125FHM-N85 Product Specification

1 OF 33

NV125FHM-N85 Final Product Specification

Rev. P2

HEFEI BOE OPTOELECTRONICS TECHNOLOGY

LCM:NV125FHM-N85

REVISION HISTORY

REV.	ECN No.	DESCRIPTION OF CHANGES	DATE	PREPARED
P0	-	Initial Release	2019.04.12	王时飞
P1	-	1. Mechanical outline dimension update 2. Label update	2019.07.15	何成亮
P2	-	Modify Label information/Packing information Modify Mechanical outline demension	2019.09.06	王琦

Contents

No.	Items	Page
1.0	General Description	4
2.0	Absolute Maximum ratings	6
3.0	Electrical specifications.	7
4.0	Optical specifications.	10
5.0	Interface Connection	15
6.0	Signal Timing Specification	18
7.0	Input Signals, Display Colors & Gray Scale of Colors	20
8.0	Power Sequence	21
9.0	Connector description	22
10.0	Mechanical Characteristics	23
11.0	Reliability Test	24
12.0	Handling & Cautions.	24
13.0	Label	25
14.0	Packing information	27
15.0	Mechanical Outline Dimension	28
16.0	EDID Table	30

1.0 GENERAL DESCRIPTION

1.1 Introduction

NV125FMH-N85 is a color active matrix TFT LCD module using amorphous silicon TFT's (Thin Film Transistors) as an active switching devices. This module has a 12.5 inch diagonally measured active area with FHD resolutions (1920 horizontal by 1080 vertical pixel array). Each pixel is divided into RED, GREEN, BLUE dots which are arranged in vertical Stripe and this module can display 16.7M colors. The TFT-LCD panel used for this module is a low reflection and higher color type. Therefore, this module is suitable for Notebook PC. The LED Driver for back-light driving is built in this model.

All input signals are eDP interface compatible.

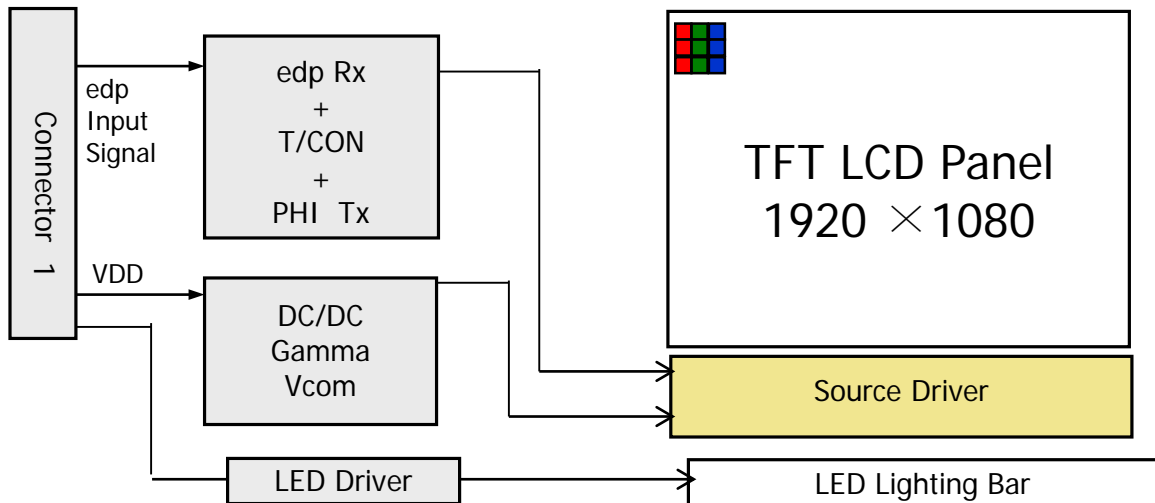

1.2 Features

- 2 lane eDP Interface with 2.7Gbps Link Rates
- Thin and light weight
- 8-bit color depth, display 16.7M colors
- Single LED Lighting Bar. (Down side/Horizontal Direction)
- No Mounting frame
- Green Product (RoHS & Halogen free product)
- On board LED Driving circuit
- Low driving voltage and low power consumption
- On board EDID chip

1.3 Application

- Notebook PC

1.4 General Specification

The followings are general specifications at the model NV125FHM-N85. (listed in Table 1.)

<Table 1. General Specifications>

Parameter	Specification	Unit	Remarks
Active area	276.48(H) × 155.52(V)	mm	
Number of pixels	1920 (H) × 1080 (V)	pixels	
Pixel pitch	0.048 × RGB × 0.144	mm	
Pixel arrangement	RGB Vertical stripe		
Display colors	16.7M	colors	
Display mode	Normally Black		
Dimensional outline	282.4(Typ)*168.72(Typ)*2.336(Max) Body 282.4(Typ)*168.72(Typ)*4.161(Max) PCB Side	mm	tol. refers drawing
Weight	171.95 (max)	g	
Surface treatment	AG		
Back-light	Lower edge side, 1-LED Lighting Bar type		Note 1
Power consumption	P _D : 0.8	W	Note 2
	P _{BL} : 2.02	W	
	P _{total} : 2.82	W	

Notes : 1. LED Lighting Bar (27*LED Array)

Notes : 2. Evaluated at Mosaic Pattern

2.0 ABSOLUTE MAXIMUM RATINGS

The followings are maximum values which, if exceed, may cause faulty operation or damage to the unit. The operational and non-operational maximum voltage and current values are listed in Table 2.

< Table 2. Absolute Maximum Ratings >

Ta=25+/-2°C

Parameter	Symbol	Min.	Max.	Unit	Remarks
Power Supply Voltage	V _{DD}	-0.3	4.0	V	Note 1
Logic Supply Voltage	V _{IN}	V _{SS} -0.3	V _{DD} +0.3	V	
Operating Temperature	T _{OP}	0	+50	°C	Note 2
Storage Temperature	T _{ST}	-20	+60	°C	

- Notes : 1. Permanent damage to the device may occur if maximum values are exceeded functional operation should be restricted to the condition described under normal operating conditions.
2. Temperature and relative humidity range are shown in the figure below.
 95 % RH Max. (40 °C ≥ Ta)
 Maximum wet - bulb temperature at 39 °C or less. (Ta > 40 °C) No condensation.

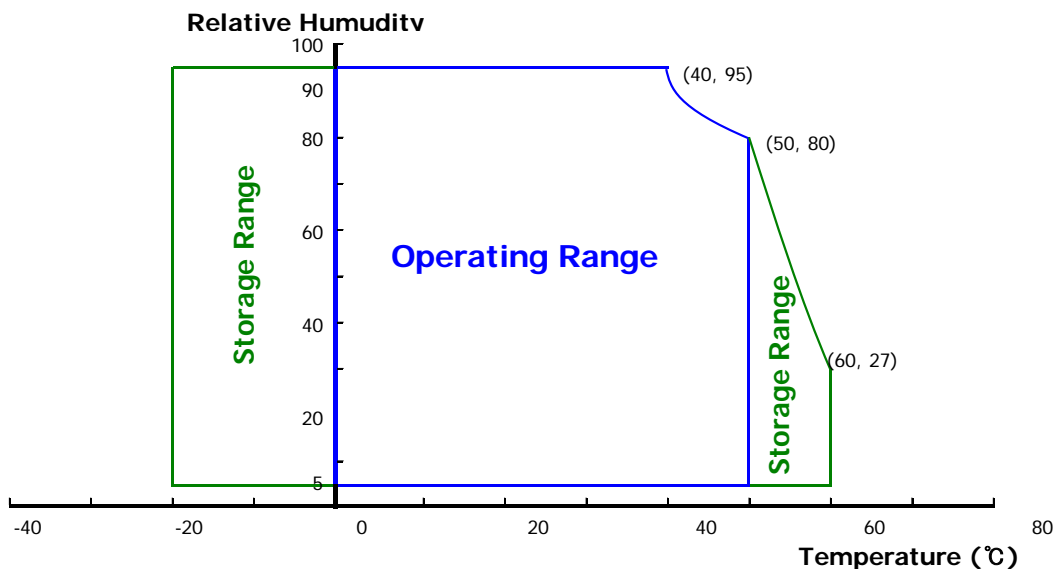

3.0 ELECTRICAL SPECIFICATIONS

3.1 LCM Electrical Specifications

< Table 3. Electrical specifications >

Ta=25+/-2°C

Parameter		Min.	Typ.	Max.	Unit	Remarks
Power Supply Voltage	V _{DD}	3.0	3.3	3.6	V	Note 1
Permissible Input Ripple Voltage	V _{RF}	-	-	100	mV	At V _{DD} = 3.3V
Power Supply Current	I _{DD}	-	243	-	mA	Note 1
Positive-going Input Threshold Voltage	V _{IT+}	-	-	100	mV	V _{cm} = 1.2V typ.
Negative-going Input Threshold Voltage	V _{IT-}	-100	-	-	mV	
Differential Input Voltage	V _{ID}	380	-	1200	mV	
Power Consumption	P _D	-	-	0.8	W	Note 1
	P _{BL}	-	-	2.02	W	Note 2
	P _{total}	-	-	2.82	W	

Notes : 1. The supply voltage is measured and specified at the interface connector of LCM.
The current draw and power consumption specified is for 3.3V at 25°C.
@Mosaic pattern

2. Calculated value for reference (27x V_{LED} × I_{LED} / Driver Eff.)

3.2 Backlight Unit

< Table 4. LED Driving guideline specifications >

Ta=25+/-2°C

Parameter		Min.	Typ.	Max.	Unit	Remarks
LED Forward Voltage	V _F	-	-	2.9	V	-
LED Forward Current	I _F	-	22	-	mA	-
LED Power Consumption	P _{LED}		-	2.02	W	Note 1
LED Life-Time	N/A	15,000	-	-	Hour	I _F = 22mA
Power supply voltage for LED Driver	V _{LED}	5	12	21	V	
EN Control Level	Backlight on	2.0		5.0	V	
	Backlight off	0		0.6	V	
PWM Control Level	PWM High Level	2.0		5.0	V	
	PWM Low Level	0		0.6	V	
PWM Control Frequency	F _{PWM}	200	-	25,000	Hz	
Duty Ratio	-	1	-	100	%	

Notes : 1. Power supply voltage 12V for LED Driver, Driver efficiency 87%,

Calculator Value for reference $I_F \times V_F \times 27 / 0.87 = P_{LED}$

2. The LED Life-time define as the estimated time to 50% degradation of initial luminous.

3.3 LED structure

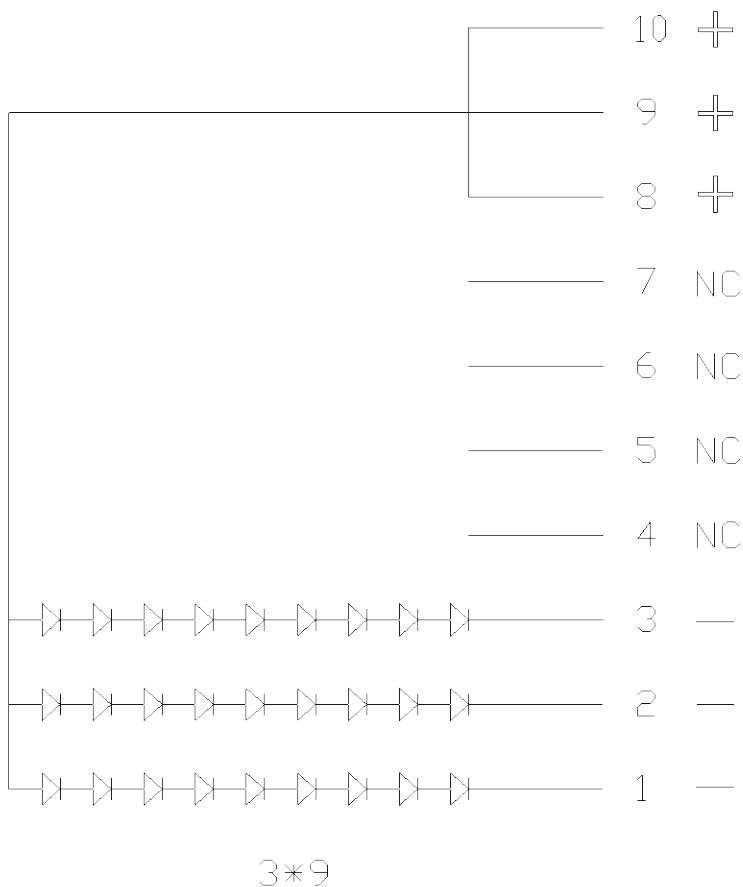

4.0 OPTICAL SPECIFICATION

4.1 Overview

The test of Optical specifications shall be measured in a dark room (ambient luminance ≤ 1 lux and temperature = $25 \pm 2^\circ\text{C}$) with the equipment of Luminance meter system (Goniometer system and TOPCON BM-5) and test unit shall be located at an approximate distance 50cm from the LCD surface at a viewing angle of θ and Φ equal to 0° . We refer to $\theta\emptyset=0$ ($=\theta_3$) as the 3 o'clock direction (the "right"), $\theta\emptyset=90$ ($=\theta_{12}$) as the 12 o'clock direction ("upward"), $\theta\emptyset=180$ ($=\theta_9$) as the 9 o'clock direction ("left") and $\theta\emptyset=270$ ($=\theta_6$) as the 6 o'clock direction ("bottom"). While scanning θ and/or \emptyset , the center of the measuring spot on the Display surface shall stay fixed. The backlight should be operating for 30 minutes prior to measurement. VDD shall be $3.3 \pm 0.3\text{V}$ at 25°C . Optimum viewing angle direction is 6 'clock.

4.2 Optical Specifications

<Table 5. Optical Specifications Base on NV125FHM-N85>

Parameter		Symbol	Condition	Min.	Typ.	Max.	Unit	Remark
Viewing Angle range	Horizontal	Θ_3	CR > 10	80	85	-	Deg.	Note 1
		Θ_9		80	85	-	Deg.	
	Vertical	Θ_{12}		80	85	-	Deg.	
		Θ_6		80	85	-	Deg.	
Luminance Contrast ratio		CR	$\Theta = 0^\circ$		AG 600	-		Note 2
Luminance of White	5 Points	Y_w	$\Theta = 0^\circ$ ILED = 22mA	255	300	-	cd/m ²	Note 3
White Luminance uniformity	5 Points	ΔY_5		80	-	-		Note 4
	13 Points	ΔY_{13}		65	-	-		
White Chromaticity		x_w	$\Theta = 0^\circ$	0.283	0.313	0.343		Note 5
		y_w		0.299	0.329	0.359		
Reproduction of color	Red	x_R	$\Theta = 0^\circ$	-0.03	0.604	+0.03	-	
		y_R			0.352			
	Green	x_G			0.343			
		y_G			0.568			
	Blue	x_B			0.159			
		y_B			0.119			
Gamut				45	50	-	%	
Response Time (Rising + Falling)		T_{RT}	Ta= 25°C $\Theta = 0^\circ$	-	30	-	ms	Note 6
Cross Talk		CT	$\Theta = 0^\circ$	-	-	2.0	%	Note 7

Notes :

1. Viewing angle is the angle at which the contrast ratio is greater than 10. The viewing angles are determined for the horizontal or 3, 9 o'clock direction and the vertical or 6, 12 o'clock direction with respect to the optical axis which is normal to the LCD surface (see FIGURE 1).

2. Contrast measurements shall be made at viewing angle of $\Theta = 0$ and at the center of the LCD surface. Luminance shall be measured with all pixels in the view field set first to white, then to the dark (black) state .
(see FIGURE 1) Luminance Contrast Ratio (CR) is defined mathematically.

$$CR = \frac{\text{Luminance when displaying a white raster}}{\text{Luminance when displaying a black raster}}$$

3. Center Luminance of white is defined as luminance values of 5 point average across the LCD surface. Luminance shall be measured with all pixels in the view field set first to white. This measurement shall be taken at the locations shown in FIGURE 2 for a total of the measurements per display.

4. The White luminance uniformity on LCD surface is then expressed as : $\Delta Y = \text{Minimum Luminance of 5(or 13) points} / \text{Maximum Luminance of 5(or 13) points}$.
(see FIGURE 2 and FIGURE 3).

5. The color chromaticity coordinates specified in Table 5 shall be calculated from the spectral data measured with all pixels first in red, green, blue and white. Measurements shall be made at the center of the panel.

6. The electro-optical response time measurements shall be made as FIGURE 4 by switching the "data" input signal ON and OFF. The times needed for the luminance to change from 10% to 90% is T_r , and 90% to 10% is T_d .

7. Cross-Talk of one area of the LCD surface by another shall be measured by comparing the luminance (Y_A) of a 25mm diameter area, with all display pixels set to a gray level, to the luminance (Y_B) of that same area when any adjacent area is driven dark.
(See FIGURE 5).

4.3 Optical measurements

Figure 1. Measurement Set Up

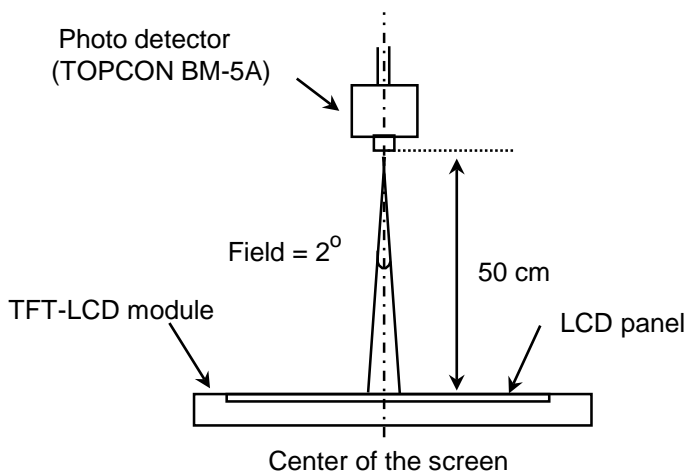

Optical characteristics measurement setup

Figure 2. White Luminance and Uniformity Measurement Locations (5 points)

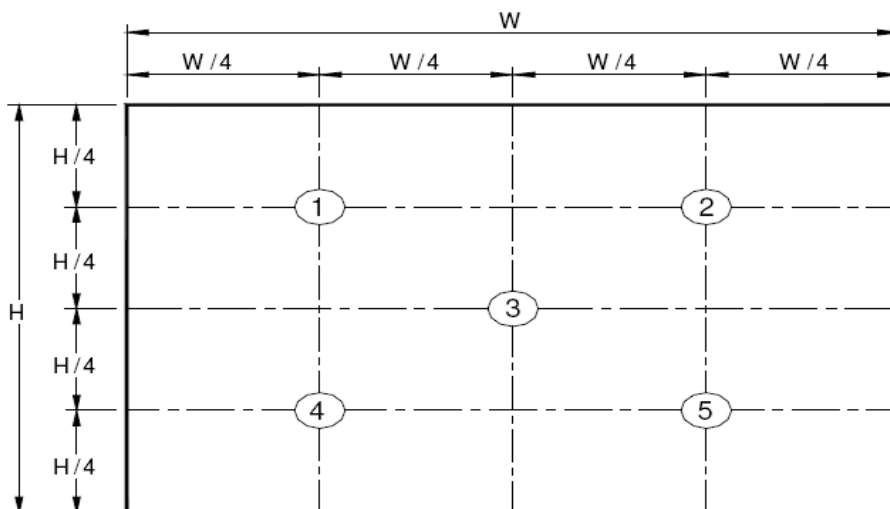

Center Luminance of white is defined as luminance values of center 5 points across the LCD surface. Luminance shall be measured with all pixels in the view field set first to white. This measurement shall be taken at the locations shown in FIGURE 2 for a total of the measurements per display.

Figure 3. Uniformity Measurement Locations (13 points)

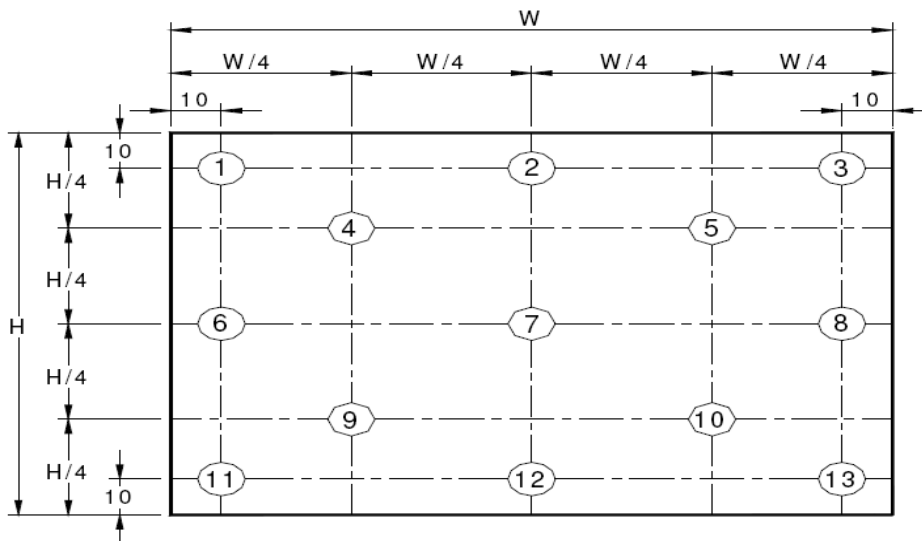

The White luminance uniformity on LCD surface is then expressed as : $\Delta Y_5 = \text{Minimum Luminance of five points} / \text{Maximum Luminance of five points}$ (see FIGURE 2) , $\Delta Y_{13} = \text{Minimum Luminance of 13 points} / \text{Maximum Luminance of 13 points}$ (see FIGURE 3).

Figure 4. Response Time Testing

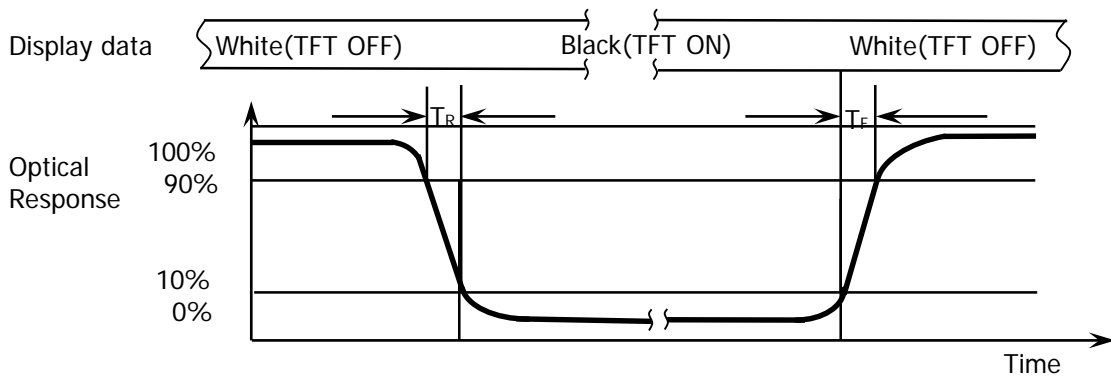

The electro-optical response time measurements shall be made as shown in FIGURE 4 by switching the “data” input signal ON and OFF. The times needed for the luminance to change from 10% to 90% is T_d and 90% to 10% is T_r .

Figure 5. Cross Modulation Test Description

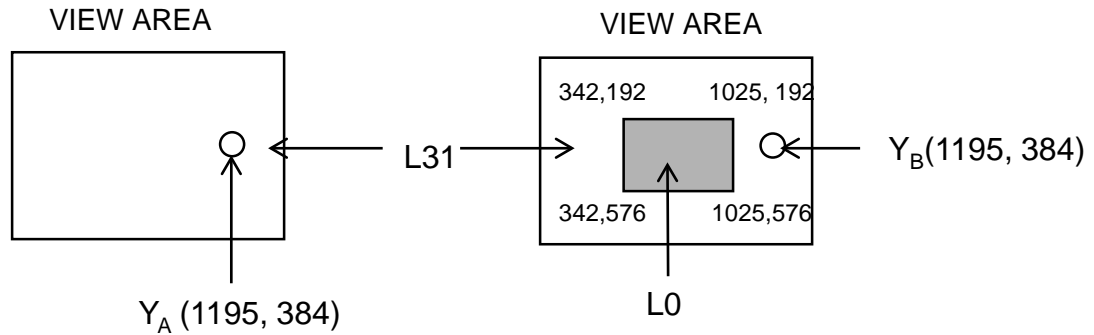

$$\text{Cross-Talk (\%)} = \left| \frac{Y_B - Y_A}{Y_A} \right| \times 100$$

Where:

Y_A = Initial luminance of measured area (cd/m^2)

Y_B = Subsequent luminance of measured area (cd/m^2)

The location measured will be exactly the same in both patterns

Cross-Talk of one area of the LCD surface by another shall be measured by comparing the luminance (Y_A) of a 25mm diameter area, with all display pixels set to a gray level, to the luminance (Y_B) of that same area when any adjacent area is driven dark (Refer to FIGURE 5).

5.0 INTERFACE CONNECTION.**5.1 Electrical Interface Connection**

The electronics interface connector is STM. The mating connector part number is I-PEX 20454-030T or Compatible. The connector interface pin assignments are listed in Table 6.

<Table 6. Pin Assignments for the Interface Connector>

Terminal	Symbol	Functions
Pin No.	Symbol	Description
1	NC	NC (Reserved For CABC)
2	H_GND	Ground
3	LANE1_N	eDP RX channel 1 negative
4	LANE1_P	eDP RX channel 1 positive
5	H_GND	Ground
6	LANE0_N	eDP RX channel 0 negative
7	LANE0_P	eDP RX channel 0 positive
8	H_GND	Ground
9	AUX_CH_P	eDP AUX CH positive
10	AUX_CH_N	eDP AUX CH negative
11	H_GND	Ground
12	LCD_VCC	Power Supply, 3.3V (typ.)
13	LCD_VCC	Power Supply, 3.3V (typ.)
14	NC	NC (Reserved For BIST)
15	H_GND	Ground
16	H_GND	Ground
17	HPD	Hot plug detect output
18	BL_GND	LED Ground
19	BL_GND	LED Ground
20	BL_GND	LED Ground
21	BL_GND	LED Ground
22	BL_ENABLE	LED enable pin(+3.3V Input)
23	BL_PWM	System PWM Signal Input
24	NC	NC (Reserved For H-SYNC)
25	NC	No Connection
26	BL_POWER	LED Power Supply 5V-21V
27	BL_POWER	LED Power Supply 5V-21V
28	BL_POWER	LED Power Supply 5V-21V
29	BL_POWER	LED Power Supply 5V-21V
30	NC	No Connection

5.2. eDP Interface

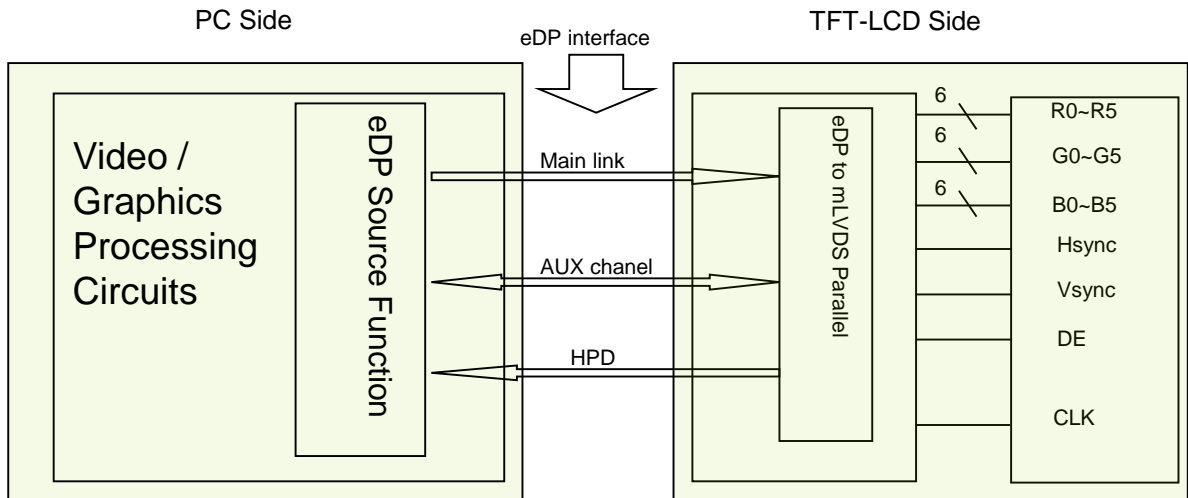

Note. Transmitter : Parade DP661A or equivalent.
Transmitter is not contained in Module.

5.3.eDP Input signal

Lane 0	Lane 1
R0-5:0 G0-5:4	R1-5:0 G1-5:4
G0-3:0 B0-5:2	G1-3:0 B1-5:2
B0-1:0 R2-5:0	B1-1:0 R3-5:0
G2-5:0 B2-5:4	G3-5:0 B3-5:4
B2-3:0 R4-5:2	B3-3:0 R5-5:2
R4-1:0 G4-5:0	R5-1:0 G5-5:0
B4-5:0 R6-5:4	B5-5:0 R7-5:4
R6-3:0 G6-5:2	R7-3:0 G7-5:2
R6-1:0 G6-5:0	R7-1:0 G7-5:0

5.4 Back-light & LCM Interface Connection

Interface Connector: **STM MSK24022P10D**

<Table 7. Pin Assignments for the BLU & LCM Connector>

Pin No.	Symbol	Description	Pin No.	Symbol	Description
1	LED1	LED cathode connection	6	NC	No Connection
2	LED2	LED cathode connection	7	NC	No Connection
3	LED3	LED cathode connection	8	Vout	LED anode connection
4	NC	No Connection	9	Vout	LED anode connection
5	NC	No Connection	10	Vout	LED anode connection

6.0 SIGNAL TIMING SPECIFICATION

6.1 Timing Parameters

Item		Symbols	Min	Typ	Max	Unit
Clock	Frequency	1/Tc	-	140.25	-	MHz
	High Time	Tch	-	4/7	-	Tc
	Low Time	Tcl	-	3/7	-	Tc
Frame Period		Tv	-	1100	-	lines
			-	60	-	Hz
			-	16.7	-	ms
Vertical Display Period		Tvd	-	1080	-	lines
One line Scanning Period		Th	-	2125	-	clocks
Horizontal Display Period		Thd	-	1920	-	clocks

6.2 eDP Rx Interface Timing Parameter

The specification of the eDP Rx interface timing parameter is shown in Table 8.

<Table 8. eDP Rx Interface Timing Specification>

Item	Symbol	Min	Typ	Max	Unit	Remark
Spread spectrum clock	SSC		0.5		%	
Differential peak-to-peak input voltage at package pins	VRX-DIFFp-p	100	0	1320	mV	
Rx input DC common mode voltage	VRX_DC_CM	-	GND	-	V	
Differential termination resistance	RRX-DIFF	80	100	120	Ω	
Single-ended termination resistance	RRX-SE	40	-	60	Ω	
Rx short circuit current limit	IRX_SHORT	-	-	20	mA	
Intra-pair skew at Rx package pins (HBR) RX intra-pair skew tolerance at HBR	LRX_SKEW_INTRA_PAIR	-	-	150	ps	

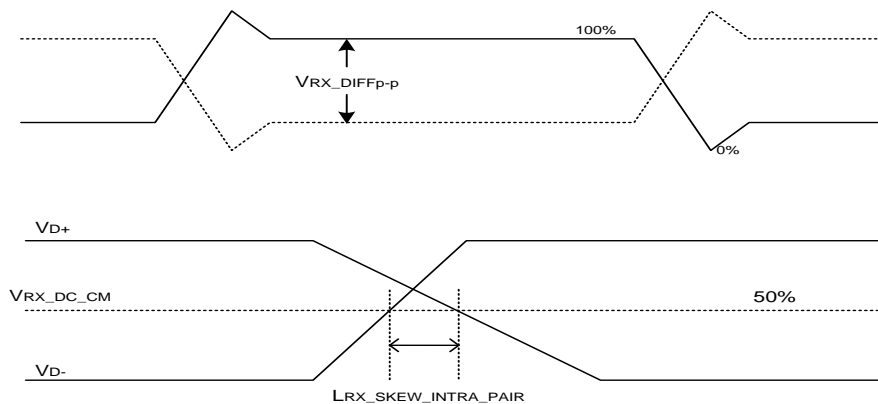

7.0 INPUT SIGNALS, BASIC DISPLAY COLORS & GRAY SCALE OF COLORS

	Colors & Gray scale	Data signal																							
		R0	R1	R2	R3	R4	R5	R6	R7	G0	G1	G2	G3	G4	G5	G6	G7	B0	B1	B2	B3	B4	B5	B6	B7
Basic colors	Black	0	0	0	0	0	0	0	0	0	0	0	0	0	0	0	0	0	0	0	0	0	0	0	0
	Blue	0	0	0	0	0	0	0	0	0	0	0	0	0	0	0	0	1	1	1	1	1	1	1	1
	Green	0	0	0	0	0	0	0	0	1	1	1	1	1	1	1	1	0	0	0	0	0	0	0	0
	Light Blue	0	0	0	0	0	0	0	0	1	1	1	1	1	1	1	1	1	1	1	1	1	1	1	1
	Red	1	1	1	1	1	1	1	1	0	0	0	0	0	0	0	0	0	0	0	0	0	0	0	0
	Purple	1	1	1	1	1	1	1	1	0	0	0	0	0	0	0	0	1	1	1	1	1	1	1	1
	Yellow	1	1	1	1	1	1	1	1	1	1	1	1	1	1	1	1	0	0	0	0	0	0	0	0
	White	1	1	1	1	1	1	1	1	1	1	1	1	1	1	1	1	1	1	1	1	1	1	1	1
Gray scale of Red	Black	0	0	0	0	0	0	0	0	0	0	0	0	0	0	0	0	0	0	0	0	0	0	0	
	△	1	0	0	0	0	0	0	0	0	0	0	0	0	0	0	0	0	0	0	0	0	0	0	
	Darker	0	1	0	0	0	0	0	0	0	0	0	0	0	0	0	0	0	0	0	0	0	0	0	
	△	↑							↑							↑									
	▽	↓							↓							↓									
	Brighter	1	0	1	1	1	1	1	1	0	0	0	0	0	0	0	0	0	0	0	0	0	0	0	0
	▽	0	1	1	1	1	1	1	1	0	0	0	0	0	0	0	0	0	0	0	0	0	0	0	0
Red	1	1	1	1	1	1	1	1	0	0	0	0	0	0	0	0	0	0	0	0	0	0	0	0	
Gray scale of Green	Black	0	0	0	0	0	0	0	0	0	0	0	0	0	0	0	0	0	0	0	0	0	0	0	
	△	0	0	0	0	0	0	0	0	1	0	0	0	0	0	0	0	0	0	0	0	0	0	0	
	Darker	0	0	0	0	0	0	0	0	0	1	0	0	0	0	0	0	0	0	0	0	0	0	0	
	△	↑							↑							↑									
	▽	↓							↓							↓									
	Brighter	0	0	0	0	0	0	0	0	1	0	1	1	1	1	1	1	0	0	0	0	0	0	0	0
	▽	0	0	0	0	0	0	0	0	0	1	1	1	1	1	1	1	0	0	0	0	0	0	0	0
Green	0	0	0	0	0	0	0	0	1	1	1	1	1	1	1	1	0	0	0	0	0	0	0	0	
Gray scale of Blue	Black	0	0	0	0	0	0	0	0	0	0	0	0	0	0	0	0	0	0	0	0	0	0	0	
	△	0	0	0	0	0	0	0	0	0	0	0	0	0	0	0	0	1	0	0	0	0	0	0	
	Darker	0	0	0	0	0	0	0	0	0	0	0	0	0	0	0	0	0	1	0	0	0	0	0	
	△	↑							↑							↑									
	▽	↓							↓							↓									
	Brighter	0	0	0	0	0	0	0	0	0	0	0	0	0	0	0	0	1	0	1	1	1	1	1	1
	▽	0	0	0	0	0	0	0	0	0	0	0	0	0	0	0	0	0	1	1	1	1	1	1	1
Blue	0	0	0	0	0	0	0	0	0	0	0	0	0	0	0	0	1	1	1	1	1	1	1	1	
Gray scale of White & Black	Black	0	0	0	0	0	0	0	0	0	0	0	0	0	0	0	0	0	0	0	0	0	0	0	
	△	1	0	0	0	0	0	0	0	1	0	0	0	0	0	0	0	1	0	0	0	0	0	0	
	Darker	0	1	0	0	0	0	0	0	0	1	0	0	0	0	0	0	0	1	0	0	0	0	0	
	△	↑							↑							↑									
	▽	↓							↓							↓									
	Brighter	1	0	1	1	1	1	1	1	1	0	1	1	1	1	1	1	1	0	1	1	1	1	1	1
	▽	0	1	1	1	1	1	1	1	0	1	1	1	1	1	1	1	0	1	1	1	1	1	1	1
White	1	1	1	1	1	1	1	1	1	1	1	1	1	1	1	1	1	1	1	1	1	1	1	1	

8.0 POWER SEQUENCE

To prevent a latch-up or DC operation of the LCD module, the power on/off sequence shall be as shown in below

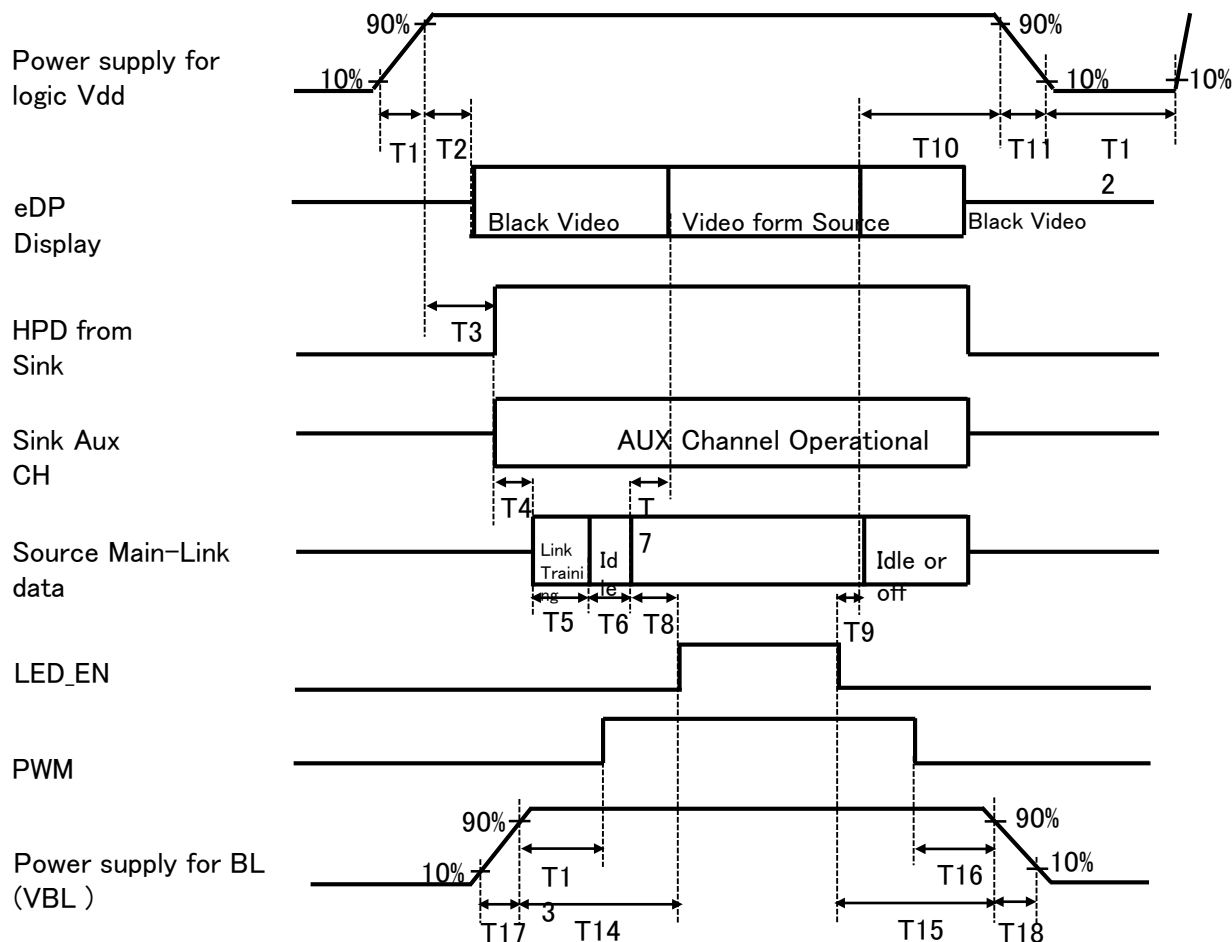

- 0.5ms ≤ T1 ≤ 10 ms
- 0ms ≤ T2 ≤ 200 ms
- 0ms ≤ T3 ≤ 200 ms
- 0ms ≤ T13
- 0ms ≤ T14
- 0ms ≤ T17
- 0ms ≤ T7 ≤ 50ms
- 0ms ≤ T10 ≤ 500 ms
- 0 ms ≤ T11 ≤ 10 ms
- 150ms ≤ T12
- 0ms ≤ T15
- 0ms ≤ T16
- 0ms ≤ T18

Notes:

1. When the power supply VDD is 0V, keep the level of input signals on the low or keep high impedance.
2. Do not keep the interface signal high impedance when power is on. Back Light must be turn on after power for logic and interface signal are valid.

9.0 Connector Description

Physical interface is described as for the connector on LCM.

These connectors are capable of accommodating the following signals and will be following components.

9.1 TFT LCD Module

Connector Name /Description	For Signal Connector
Manufacturer	IPEX
Type/ Part Number	20455-030E-66

10.0 MECHANICAL CHARACTERISTICS

10.1 Dimensional Requirements

FIGURE 6 shows mechanical outlines for the model HB125WX1-201.
Other parameters are shown in Table 9.

<Table 9. Dimensional Parameters>

Parameter	Specification	Unit
Active Area	276.48 (H) × 155.52(V)	
Number of pixels	1920 (H) X 1080 (V) (1 pixel = R + G + B dots)	
Pixel pitch	0.048(H) X 0.144 (V)	
Pixel arrangement	RGB Vertical stripe	
Display colors	16.7M	
Display mode	Normally black	
Dimensional outline	282.4(Typ)*168.72(Typ)*2.336(Max) Body 282.4(Typ)*168.72(Typ)*4.161(Max) PCB Side	mm
Weight	171.95 (Max)	gram
Back Light	Connector :STM MSK24022P10D	
	LED, Horizontal-LED Array type	

10.2 Mounting

See FIGURE 6.

10.3 Anti-Glare and Polarizer Hardness.

The surface of the LCD has an anti glare coating to maximize readability and hard coating to reduce scratching.

10.4 Light Leakage

There shall not be visible light from the back-lighting system around the edges of the screen as seen from a distance 50cm from the screen with an overhead light level of 350lux.

11.0 RELIABILITY TEST

The Reliability test items and its conditions are shown in below.

<Table 10. Reliability test>

No	Test Items	Conditions
1	High temperature storage test	Ta = 60 °C, 240 hrs
2	Low temperature storage test	Ta = -20 °C, 240 hrs
3	High temperature & high humidity operation test	Ta = 50 °C, 80%RH, 240 hrs
4	High temperature operation test	Ta = 50 °C, 240 hrs
5	Low temperature operation test	Ta = 0 °C, 240 hrs
6	Thermal shock	Ta = -20 °C ↔ 60 °C (0.5 hr), 100 cycle
7	Vibration test (non-operating)	1.5G, 10~500Hz, Half Sine X,Y,Z / Sweep rate : 1 hour
8	Shock test (non-operating)	220G, Half Sine Wave 2msec ±X, ±Y, ±Z Once for each direction
9	Electro-static discharge test (non-operating)	Air : 150 pF, 330Ω, 15 KV Contact : 150 pF, 330Ω, 8 KV

12.0 HANDLING & CAUTIONS

(1) Cautions when taking out the module

- Pick the pouch only, when taking out module from a shipping package.

(2) Cautions for handling the module

- As the electrostatic discharges may break the LCD module, handle the LCD module with care. Peel a protection sheet off from the LCD panel surface as slowly as possible.
- As the LCD panel and back - light element are made from fragile glass material, impulse and pressure to the LCD module should be avoided.
- As the surface of the polarizer is very soft and easily scratched, use a soft dry cloth without chemicals for cleaning.
- Do not pull the interface connector in or out while the LCD module is operating.
- Put the module display side down on a flat horizontal plane.
- Handle connectors and cables with care.

(3) Cautions for the operation

- When the module is operating, do not lose CLK, ENAB signals. If any one of these signals is lost, the LCD panel would be damaged.
- Obey the supply voltage sequence. If wrong sequence is applied, the module would be damaged.

(4) Cautions for the atmosphere

- Dew drop atmosphere should be avoided.
- Do not store and/or operate the LCD module in a high temperature and/or humidity atmosphere. Storage in an electro-conductive polymer packing pouch and under relatively low temperature atmosphere is recommended.

(5) Cautions for the module characteristics

- Do not apply fixed pattern data signal to the LCD module at product aging.
- Applying fixed pattern for a long time may cause image sticking.

(6) Other cautions

- Do not disassemble and/or re-assemble LCD module.
- Do not re-adjust variable resistor or switch etc.
- When returning the module for repair or etc., Please pack the module not to be broken. We recommend to use the original shipping packages.

13.0 LABEL

(1) LCM Label

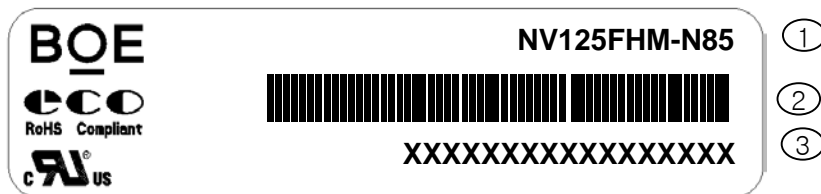

LCM Label Explain

Total Size:48*12mm

Serial number marked part needs to print, show as follows::

Product FG-Code before 12 : NV125FHM-N85

1. FG-Code
2. BOE MDL ID BAR CODE
3. BOE MDL ID

序号号	1	2	3	4	5	6	7	8	9	10	11	12	13	14	15	16	17
代码	X	X	X	3	X	X	X	3	R	A	0	X	X	X	X	X	X
描述	GBN Code		Grade	B3	Y	M	D	Last 4 digit of FG Code				Serial number					

Y: 2015—5, 2016—6 …….

M: 1~12→ 1~9, A,B,C

SERIERS: 0~9, A~Z (Without : I, O, Q, U)

(2) Box label

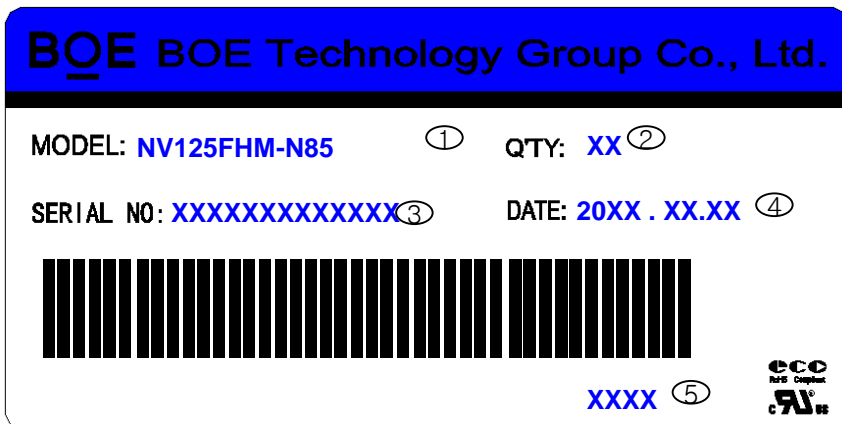

Serial number marked part needs to print, show as follows:

1. FG-CODE(Before 12)
2. Product Quantity
3. Box ID
4. Date of Packing
5. FG-Code After four

序号	1	2	3	4	5	6	7	8	9	10	11	12	13
代码	X	X	X	3	X	X	X	X	X	X	X	X	X
描述	GBN code		Grade	B3	Year		month	Rev	Serial number				

14.0 PACKING INFORMATION

14.1 Packing order

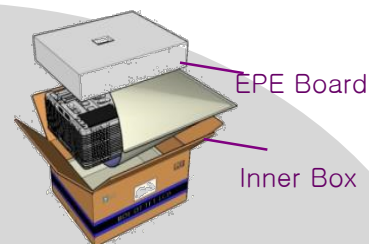
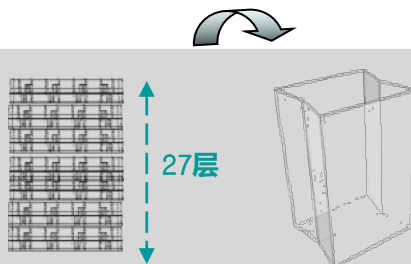
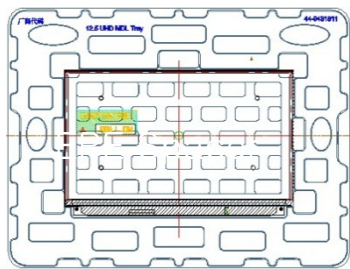

- Put 1pcs LCM in the Tray
- Capacity:25pcs LCM/27Tray
- The bottom Tray&the top tray is empty

- Put the 27 pieces Tray in the PE Bag
- Put one EPE Board in the Inner Box
- Put the PE Bag with 25pcs LCM in the EPE Board
- At last put one EPE Board
- Capacity : 25pcs LCM/Box

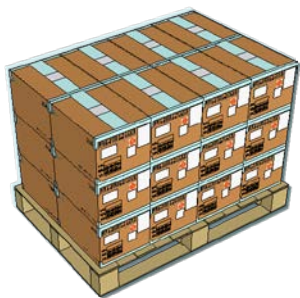

- Put 24 EA Box on the Pallet
- Secure with strapping tape, wrap around film, paper protection Angle.
-
- Capacity:8EABox/Layer,3Layer,600pcsLCM/Pallet

14.2 Notes

- Box Dimension: 375*280*290 mm
- Package Quantity in one Box: 24ea

15.0 MECHANICAL OUTLINE DIMENSION

Figure 6. TFT-LCD Module Outline Dimensions (Front view)

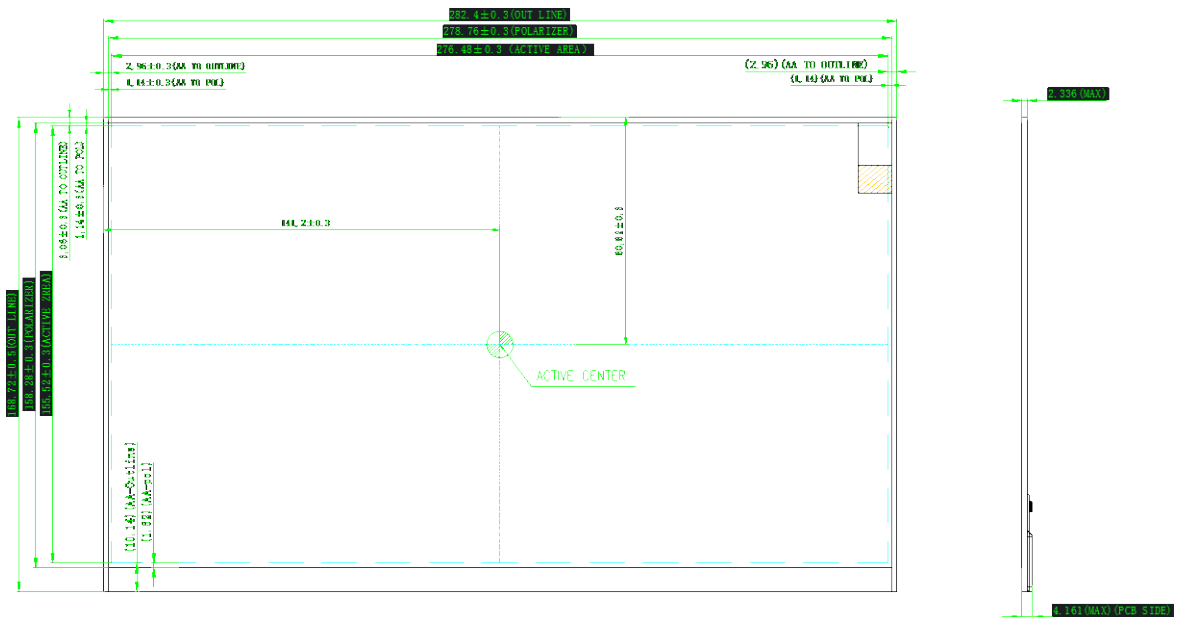
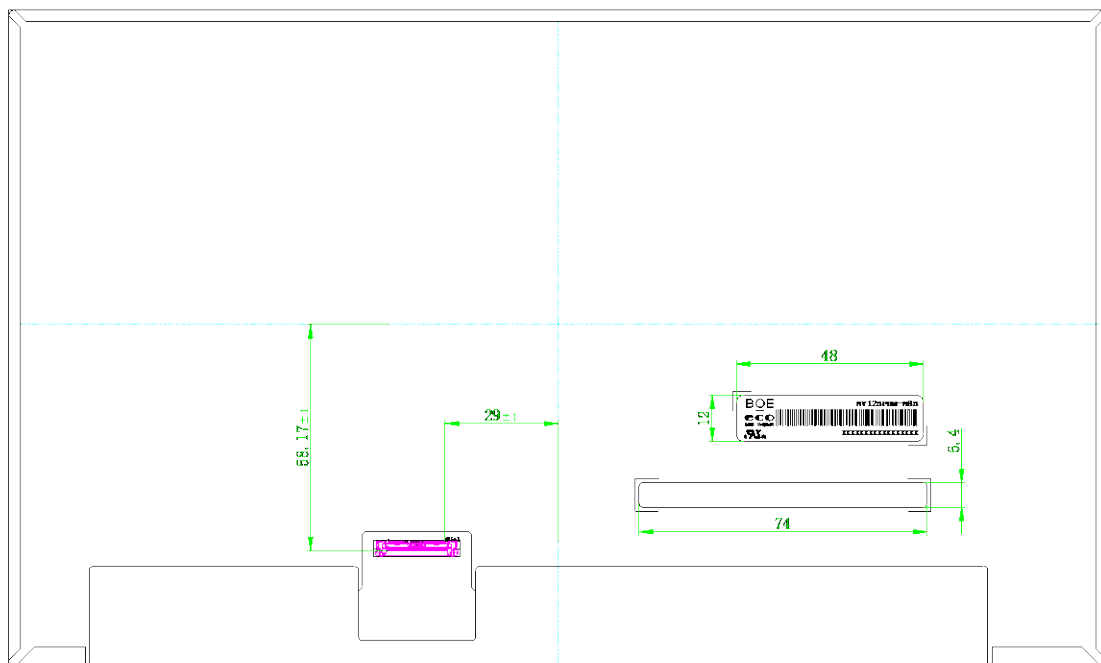

Figure 7. TFT-LCD Module Outline Dimensions (Rear view)



16.TFT EDID Table

Address (HEX)	Function	Hex	Dec	Input values.	Notes
00	Header	00	0	0	EDID Header
01		FF	255	255	
02		FF	255	255	
03		FF	255	255	
04		FF	255	255	
05		FF	255	255	
06		FF	255	255	
07		00	0	0	
08	ID Manufacturer Name	09	9	BOE	ID = BOE
09		E5	229		
0A	ID Product Code	82	130	2178	ID = 2178
0B		08	8		
0C	32-bit serial No.	00	0		
0D		00	0		
0E		00	0		
0F		00	0		
10	Week of manufacture	01	1	1	
11	Year of Manufacture	1D	29	2019	Manufactured in 2019
12	EDID Structure Ver.	01	1	1	EDID Ver 1.0
13	EDID revision #	04	4	4	EDID Rev. 0.4
14	Video input definition	A5	165	-	digital signal/DP input
15	Max H image size	1C	28	28	28 cm (Approx)
16	Max V image size	10	16	16	16 cm (Approx)
17	Display Gamma	78	120	2.2	Gamma curve = 2.2
18	Feature support	0A	10		RGB display, Preferred Timming mode
19	Red/Green low bits	F6	246	-	Red / Green Low Bits
1A	Blue/White low bits	A0	160	-	Blue / White Low Bits
1B	Red x high bits	99	153	0.601	Red (x) = 10011001 (0.601)
1C	Red y high bits	59	89	0.351	Red (y) = 01011001 (0.351)
1D	Green x high bits	51	81	0.318	Green (x) = 01010001 (0.318)
1E	Green y high bits	94	148	0.581	Green (y) = 10010100 (0.581)
1F	Blue x high bits	2D	45	0.178	Blue (x) = 00101101 (0.178)
20	BLue y high bits	1F	31	0.124	Blue (y) = 00011111 (0.124)
21	White x high bits	50	80	0.313	White (x) = 01010000 (0.313)
22	White y high bits	54	84	0.329	White (y) = 01010100 (0.329)
23	Established timing 1	00	0	-	
24	Established timing 2	00	0	-	

16.TFT EDID Table

25	Established timing 3	00	0	-	
26	Standard timing #1	01	1		Not Used
27		01	1		
28	Standard timing #2	01	1		Not Used
29		01	1		
2A	Standard timing #3	01	1		Not Used
2B		01	1		
2C	Standard timing #4	01	1		Not Used
2D		01	1		
2E	Standard timing #5	01	1		Not Used
2F		01	1		
30	Standard timing #6	01	1		Not Used
31		01	1		
32	Standard timing #7	01	1		Not Used
33		01	1		
34	Standard timing #8	01	1		Not Used
35		01	1		
36	Detailed timing/monitor descriptor #1	C9	201	140.25	140.25MHz Main clock
37		36	54		
38		80	128	1920	Hor Active = 1920
39		CD	205	205	Hor Blanking = 205
3A		70	112	-	4 bits of Hor. Active + 4 bits of Hor. Blanking
3B		38	56	1080	Ver Active = 1080
3C		14	20	20	Ver Blanking = 20
3D		40	64	-	4 bits of Ver. Active + 4 bits of Ver. Blanking
3E		30	48	48	Hor Sync Offset = 48
3F		20	32	32	H Sync Pulse Width = 32
40		36	54	3	V sync Offset = 3 line
41		00	0	6	V Sync Pulse width : 6 line
42		18	24	280	Horizontal Image Size = 280 mm (Low 8 bits)
43		A5	165	165	Vertical Image Size = 165 mm (Low 8 bits)
44		10	16	-	4 bits of Hor Image Size + 4 bits of Ver Image Size
45		00	0	0	Hor Border (pixels)
46		00	0	0	Vertical Border (Lines)
47	1A	26		Refer to right table	

16.TFT EDID Table

48	Detailed timing/monitor descriptor #2	D4	212	112.20	112.2MHz Main clock
49		2B	43		
4A		80	128	1920	Hor Active = 1920
4B		CD	205	205	Hor Blanking = 205
4C		70	112	-	4 bits of Hor. Active + 4 bits of Hor. Blanking
4D		38	56	1080	Ver Active = 1080
4E		14	20	20	Ver Blanking = 20
4F		40	64	-	4 bits of Ver. Active + 4 bits of Ver. Blanking
50		64	100	100	Hor Sync Offset = 100
51		64	100	100	H Sync Pulse Width = 100
52		44	68	20	V sync Offset = 20 line
53		05	5	20	V Sync Pulse width : 20 line
54		18	24	280	Horizontal Image Size = 280 mm (Low 8 bits)
55		A5	165	165	Vertical Image Size = 165 mm (Low 8 bits)
56		10	16	-	4 bits of Hor Image Size + 4 bits of Ver Image Size
57		00	0	0	Hor Border (pixels)
58	00	0	0	Vertical Border (Lines)	
59	1A	26			
5A	Detailed timing/monitor descriptor #3	00	0		ASCII Data Sting Tag
5B		00	0		
5C		00	0		
5D		FE	254		
5E		00	0		
5F		42	66	B	Manufacture name : BOE HF
60		4F	79	O	
61		45	69	E	
62		20	32		
63		48	72	H	
64	46	70	F		
65	0A	10			
66	20	32			
67	20	32			
68	20	32			
69	20	32			
6A	20	32			
6B	20	32			

16.TFT EDID Table

6C	Detailed timing/monitor descriptor #4	00	0		Product Name Tag (ASCII)
6D		00	0		
6E		00	0		
6F		FE	254		
70		00	0		
71		4E	78	N	Model name : NV125FHM-N85
72		56	86	V	
73		31	49	1	
74		32	50	2	
75		35	53	5	
76		46	70	F	
77		48	72	H	
78		4D	77	M	
79		2D	45	-	
7A		4E	78	N	
7B		38	56	8	
7C	35	53	5		
7D	0A	10			
7E	Extension flag	00	0		
7F	Checksum	63	99	-	

Our company network supports you worldwide with offices in Germany, Austria, Switzerland, the UK and the USA. For more information please contact:

Headquarters

Germany



FORTEC Elektronik AG

Augsburger Str. 2b
82110 Germering

Phone: +49 89 894450-0
E-Mail: info@fortecag.de
Internet: www.fortecag.de

Fortec Group Members

Austria



Distec GmbH Office Vienna

Nuschinggasse 12
1230 Wien

Phone: +43 1 8673492-0
E-Mail: info@distec.de
Internet: www.distec.de

Germany



Distec GmbH

Augsburger Str. 2b
82110 Germering

Phone: +49 89 894363-0
E-Mail: info@distec.de
Internet: www.distec.de

Switzerland



ALTRAC AG

Bahnhofstraße 3
5436 Würenlos

Phone: +41 44 7446111
E-Mail: info@altrac.ch
Internet: www.altrac.ch

United Kingdom



Display Technology Ltd.

Osprey House, 1 Osprey Court
Hichingbrooke Business Park
Huntingdon, Cambridgeshire, PE29 6FN

Phone: +44 1480 411600
E-Mail: info@displaytechnology.co.uk
Internet: www.displaytechnology.co.uk

USA



Apollo Display Technologies, Corp.

87 Raynor Avenue,
Unit 1 Ronkonkoma,
NY 11779

Phone: +1 631 5804360
E-Mail: info@apolloDisplays.com
Internet: www.apolloDisplays.com