



OUR GLOBAL  
COMPETENCE  
CENTRES

 APOLLO DISPLAY  
TECHNOLOGIES



 DISTEC



 DISPLAY  
TECHNOLOGY



# Datasheet

## Disea

**ZW-T034TQH-04CP-B**

DE-05-017



# PRODUCT SPECIFICATIONS

For Customer: \_\_\_\_\_

: APPROVAL FOR SPECIFICATION

Customer Model No. \_\_\_\_\_

: APPROVAL FOR SAMPLE

Module No.: ZW-T034TQH-04CP-B

Date : 2020-11-16

**Table of Contents**

No.	Item	Page
1	Cover Sheet(Table of Contents)	P1
2	Revision Record	P2
3	General Specifications	P3
4	Outline Drawing	P4
5	Absolute Maximum Ratings	P5
6	Electrical Specifications	P6-P8
7	Optical Characteristics	P9-P12
8	Reliability Test Items and Criteria	P13
9	Precautions for Use of LCD Modules	P14-P15

**For Customer's Acceptance:**

Approved By	Comment

PREPARED	CHECKED	VERIFIED BY QA DEPT	VERIFIED BY R&D DEPT
RCR			



### 3. General Specifications

ZW-T034TQH-04CP-B is a TFT-LCD module. It is composed of a TFT-LCD panel, driver IC, FPC, a back light ,PCB and CTP unit. The 3.4'' display area contains 800 x (RGB) x 800 pixels and can display up to 16.7M colors. This product accords with ROHS environmental criterion.

Item	Contents	Unit	Note
LCD Type	TFT	-	
Display color	16.7M	Color	1
Viewing Direction	ALL	O'Clock	
Operating temperature	-20 ~ +70	°C	
Storage temperature	-30 ~ +80	°C	
Module size	120.50 X 120.50 X 3.78	mm	2
Active Area(W×H)	87.60 X 87.60	mm	
Number of Dots	800 X 800	dots	
Controller	TC358779XBG	-	
CTP Controller	ILI2511	-	
Power Supply Voltage	5.0	V	
Backlight	4S2P-LEDs (white)	pcs	
Weight	---	g	
Interface	MICRO_HDMI & TYPE C USB	-	

*Note 1: Color tune is slightly changed by temperature and driving voltage.*

*Note 2: Without PCB,FORM and Solder.With CTP.*



## 5. Absolute Maximum Ratings( $T_a=25\text{ }^\circ\text{C}$ )

### 5.1 Electrical Absolute Maximum Ratings.( $V_{ss}=0\text{V}$ , $T_a=25\text{ }^\circ\text{C}$ )

Item	Symbol	Min.	Max.	Unit	Note
Power Supply Voltage	VCC	-0.3	6.5	V	1,2
	VBUS	-0.3	6.5	V	

Notes:

1. If the module is above these absolute maximum ratings. It may become permanently damaged. Using the module within the following electrical characteristic conditions are also exceeded, the module will malfunction and cause poor reliability.
2.  $V_{CC} > V_{SS}$  must be maintained.
3. Please be sure users are grounded when handing LCD Module.

### 5.2 Environmental Absolute Maximum Ratings.

Item	Storage		Operating		Note
	MIN.	MAX.	MIN.	MAX.	
Ambient Temperature	-30 $^\circ\text{C}$	80 $^\circ\text{C}$	-20 $^\circ\text{C}$	70 $^\circ\text{C}$	1,2
Humidity	-	-	-	-	3

Notes:

1. The response time will become lower when operated at low temperature.
2. Background color changes slightly depending on ambient temperature.  
The phenomenon is reversible.
3.  $T_a \leq 40\text{ }^\circ\text{C}$ :85%RH MAX.  
 $T_a > 40\text{ }^\circ\text{C}$ :Absolute humidity must be lower than the humidity of 85%RH at 40 $^\circ\text{C}$ .

## 6. Electrical Specifications

### 6.1 Electrical characteristics( $V_{SS}=0V, T_a=25^\circ C$ )

Parameter	Symbol	Condition	Min	Typ	Max	Unit
Power Supply Voltage	VCC	$T_a=25^\circ C$	4.8	5.0	5.2	V
	VBUS	$T_a=25^\circ C$	4.8	5.0	5.2	
Input voltage	'H'	$V_{IH}$	$0.7*VCC$	-	VCC	
	'L'	$V_{IL}$	-0.3	-	$0.3*VCC$	

### 6.2 LED backlight specification( $V_{SS}=0V, T_a=25^\circ C$ )

Item	Symbol	Condition	Min	Typ	Max	Unit	Note
Voltage for Backlight	$V_f$	$I_f=40mA$	10.8	12.0	13.2	V	
Uniformity	$\Delta Bp$	$I_f=40mA$	75	80	-	%	
Life Time	time	$I_f=40mA$	-	20K	-	hours	1

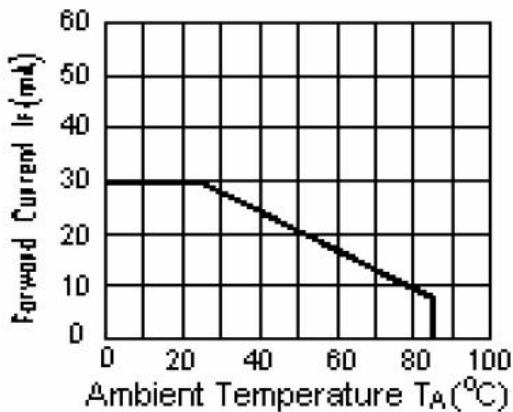

Note 1: Brightness to be decreased to 50% of the initial value at ambient temperature  $T_A=25^\circ C$



## 6.3 CN1-MICRO\_HDMI TYPE D

Pin No.	Symbol	I/O	Function
1	Hot Plug Detect	I	Hot Plug Detect
2	UTILITY	-	No Connection
3	TMDS Data 2+	I	HDMI Data 2+
4	TMDS Data2 Shield	I	HDMI Data 2 Shield
5	TMDS Data 2-	I	HDMI Data 2-
6	TMDS Data 1+	I	HDMI Data 1+
7	TMDS Data1 Shield	I	HDMI Data 1 Shield
8	TMDS Data 1-	I	HDMI Data 1-
9	TMDS Data 0+	I	HDMI Data 0+
10	TMDS Data0 Shield	I	HDMI Data 0 Shield
11	TMDS Data 0-	I	HDMI Data 0-
12	TMDS Clock+	I	HDMI Clock+
13	TMDS Clock Shield	I	HDMI Clock Shield
14	TMDS Clock-	I	HDMI Clock-
15	CEC	I	Consumer Electronics Control
16	DCC/ECE GROUND	P	DDC/CEC Ground
17	SCL	I	Serial clock
18	SDA	I	Serial Input /output data bus
19	VCC(+5 POWER)	P	Power Supply +5V

## CN2 -TYPE C USB

Pin No	Symbol	I/O	Function
A1	GND	P	Ground
A2-A3	NC	-	No connect.
A4	VBUS	P	USB 5V input power supply voltage
A5	NC	-	No connect.
A6	D+	I	USB D+
A7	D-	I	USB D-

A8	NC	-	No connect.
A9	VBUS	P	USB 5V input power supply voltage
A10-A11	NC	-	No connect.
A12	GND	P	Ground
B1	GND	P	Ground
B2-B3	NC	-	No connect.
B4	VBUS	P	USB 5V input power supply voltage
B5	NC	-	No connect.
B6	D+	I	USB D+
B7	D-	I	USB D-
B8	NC	-	No connect.
B9	VBUS	P	USB 5V input power supply voltage
B10-B11	NC	-	No connect.
B12	GND	P	Ground

### CTP Characteristics

Item	Specification	Remarks
Outline Dimension	120.50 × 120.50	mm
Total Thickness	1.13	mm
View Area	88.6 × 88.6	mm
TP size	3.4	inch
Operation Temperature	-20℃~+70℃, ≤90%RH	-
Storage Temperature	-30℃~+80℃, ≤90%RH	-
Glass Thickness	0.7	mm
Resolution	800 × 800	Dots
Surface hardness	≥6H	-
Control IC	ILI2511	-
Transparency	≥85%	-
Connection Type	FPC	-

## 7. Optical Characteristics

Item	Symbol	Condition	Min.	Typ.	Max.	Unit	Note	
Brightness	Bp	$\theta=0^\circ$ $\Phi=0^\circ$	280	350	-	Cd/m <sup>2</sup>	1	
Uniformity	$\Delta$ Bp		75	80	-	%	1,2	
Viewing Angle	3:00	Cr $\geq$ 10	-	80	-	Deg	3	
	6:00		-	80	-			
	9:00		-	80	-			
	12:00		-	80	-			
Contrast Ratio	Cr	$\theta=0^\circ$ $\Phi=0^\circ$	600	800	-	-	4	
Response Time	T <sub>r</sub> +T <sub>f</sub>		-	25	35	ms	5	
Color of CIE Coordinate	W	x	$\theta=0^\circ$ $\Phi=0^\circ$	Typ. -0.05	0.295	Typ. +0.05	-	1,6
		y			0.322		-	
	R	x			TBD		-	
		y			TBD		-	
	G	x			TBD		-	
		y			TBD		-	
	B	x			TBD		-	
		y			TBD		-	
NTSC	S		60	70	-	%		

Note: The parameter is slightly changed by temperature, driving voltage and materiel

Note 1: The data are measured after LEDs are turned on for 5 minutes. LCM displays full white.

The brightness is the average value of 9 measured spots. Measurement equipment BM-7 (Φ5mm)

Measuring condition:

- Measuring surroundings: Dark room.
- Measuring temperature:  $T_a=25\text{ }^\circ\text{C}$ .
- Adjust operating voltage to get optimum contrast at the center of the display.

Measured value at the center point of LCD panel after more than 5 minutes while backlight turning on.

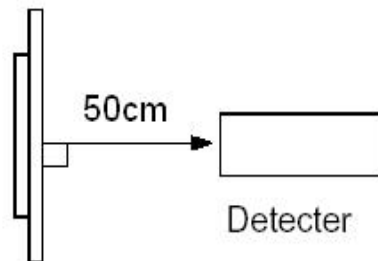

Note 2: The luminance uniformity is calculated by using following formula.

$$\Delta B_p = B_p (\text{Min.}) / B_p (\text{Max.}) \times 100 (\%)$$

$B_p (\text{Max.})$  = Maximum brightness in 9 measured spots

$B_p (\text{Min.})$  = Minimum brightness in 9 measured spots.

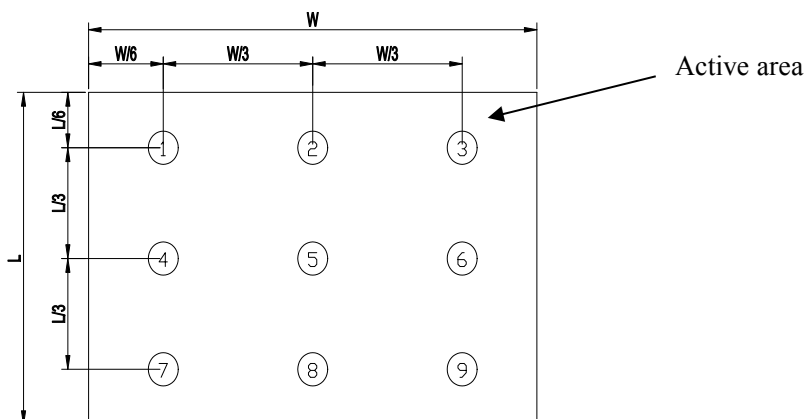

**Note 3: The definition of viewing angle:**

Refer to the graph below marked by  $\theta$  and  $\Phi$

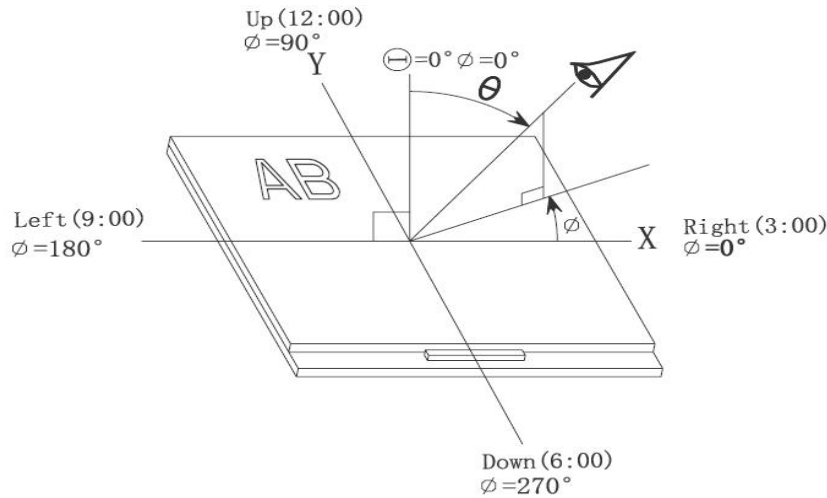

**Note 4: Definition of contrast ratio.( Test LCD using DMS501)**

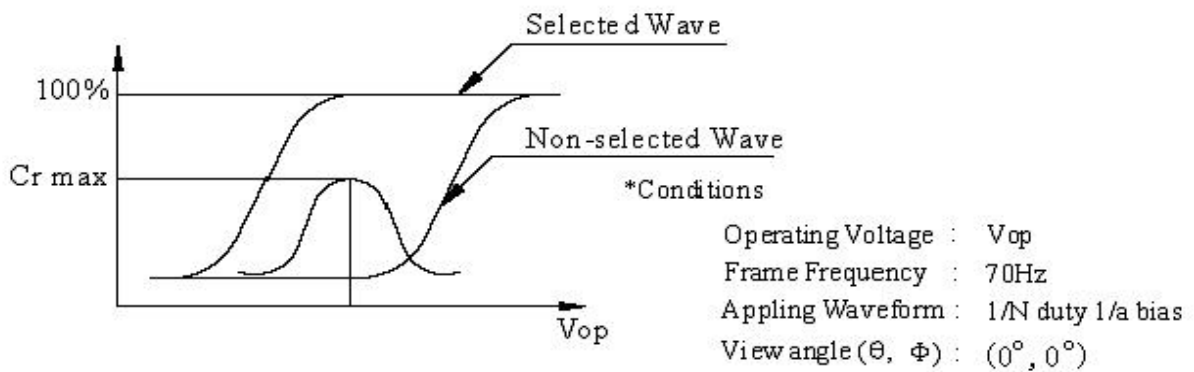

$$\text{Contrast ratio}(Cr) = \frac{\text{Brightness of selected dots}}{\text{Brightness of non-selected dots}}$$

**Note 5: Definition of Response time. (Test LCD using DMS501):**

The output signals of photo detector are measured when the input signals are changed from "black" to "white" (falling time) and from "white" to "black" (rising time), respectively. The response time is defined as the time interval between the 10% and 90% of amplitudes. Refer to figure as below.

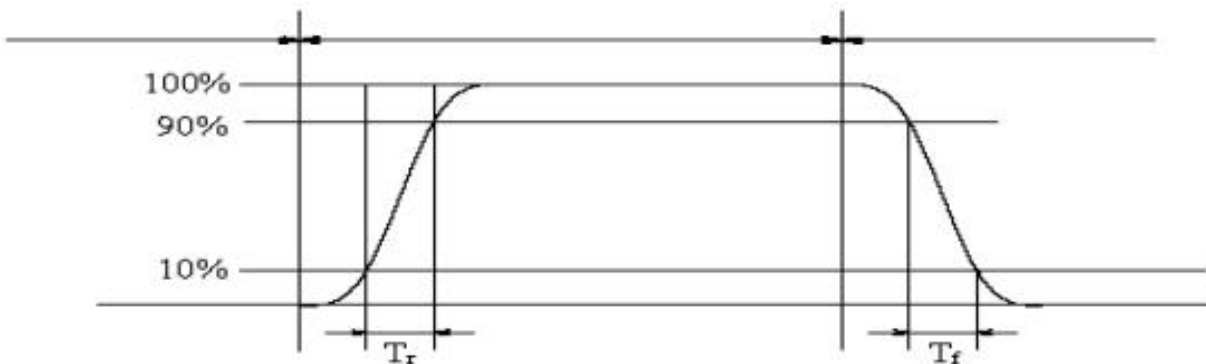

The definition of response time

Note 6: Definition of Color of CIE Coordinate and NTSC Ratio.

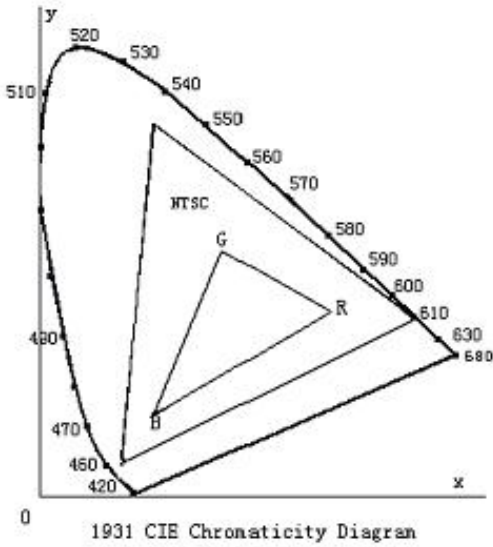

Color gamut:

$$S = \frac{\text{area of RGB triangle}}{\text{area of NTSC triangle}} \times 100\%$$

Note 7: Definition of cross talk.

Cross talk ratio(%) =  $\frac{|\text{pattern A Brightness} - \text{pattern B Brightness}|}{\text{pattern A Brightness}} \times 100$

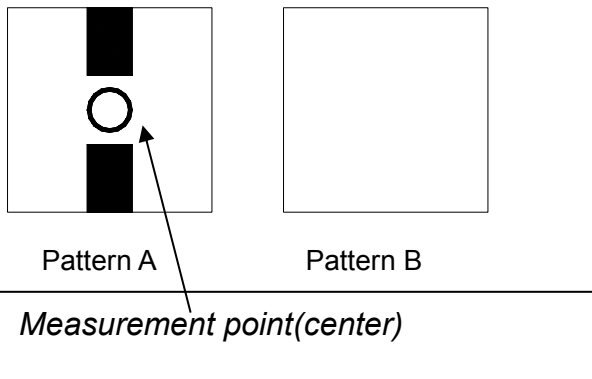

Electric volume value =  $3F \pm 3Hex$

## 8. Reliability Test Items and Criteria

Test Item	Test condition	Remark
High Temperature Storage	Ta = 80°C 96hrs	Note1,Note3, 4
Low Temperature Storage	Ta = -30°C 96hrs	Note1,Note3, 4
High Temperature Operation	Ta = 70°C 96hrs	Note2,Note3, 4
Low Temperature Operation	Ta = -20°C 96hrs	Note1,Note3, 4
Operation at High Temperature/Humidity	+60°C, 90%RH 96hrs	Note3, 4
Thermal Shock	-30°C/30 min ~ +80°C/30 min for a total 10 cycles, Start with cold temperature and end with high temperature.	Note3, 4
Vibration Test	Frequency range:10~55Hz Stroke:1.5mm Sweep:10Hz~55Hz~10Hz 2 hours for each direction of X. Y. Z. (6 hours for total)	
Mechanical Shock	100G 6ms,±X, ±Y, ±Z 3 times for each direction	
Package Vibration Test	Random Vibration : 0.015G*G/Hz from 5-200HZ, -6dB/Octave from 200-500HZ 2 hours for each direction of X. Y. Z. (6 hours for total)	
Package Drop Test	Height:60cm 1 corner, 3 edges, 6 surfaces	
Electro Static Discharge	±2KV, Human Body Mode, 100pF/1500Ω	

Note 1: Ta is the ambient temperature of samples.

Note 2: Ts is the temperature of panel's surface.

Note 3: In the standard condition, there shall be no practical problem that may affect the display function. After the reliability test, the product only guarantees operation, but don't guarantee all of the cosmetic specification.

Note 4: Before cosmetic and function test, the product must have enough recovery time,at least 2 hours at room temperature

## **9. Precautions for Use of LCD Modules**

### **9.1 Handling Precautions**

9.1.1 *The display panel is made of glass. Do not subject it to a mechanical shock by dropping it from a high place, etc.*

9.1.2 *If the display panel is damaged and the liquid crystal substance inside it leaks out, be sure not to get any in your mouth, if the substance comes into contact with your skin or clothes, promptly wash it off using soap and water.*

9.1.3 *Do not apply excessive force to the display surface or the adjoining areas since this may cause the color tone to vary.*

9.1.4 *The polarizer covering the display surface of the LCD module is soft and easily scratched. Handle this polarizer carefully.*

9.1.5 *If the display surface is contaminated, breathe on the surface and gently wipe it with a soft dry cloth. If still not completely clear, moisten cloth with one of the following solvents:*

— Isopropyl alcohol      — Ethyl alcohol

*Solvents other than those mentioned above may damage the polarizer. Especially, do not use the following:*

— Water                      — Ketone                      — Aromatic solvents

9.1.6 *Do not attempt to disassemble the LCD Module.*

9.1.7 *If the logic circuit power is off, do not apply the input signals.*

9.1.8 *To prevent destruction of the elements by static electricity, be careful to maintain an optimum work environment.*

a. *Be sure to ground the body when handling the LCD Modules.*

b. *Tools required for assembly, such as soldering irons, must be properly ground.*

c. *To reduce the amount of static electricity generated, do not conduct assembly and other work under dry conditions.*

d. *The LCD Module is coated with a film to protect the display surface. Be care when peeling off this protective film since static electricity may be generated.*



## **9.2 Storage precautions**

9.2.1 *When storing the LCD modules, avoid exposure to direct sunlight or to the light of fluorescent lamps.*

9.2.2 *The LCD modules should be stored under the storage temperature range. If the LCD modules will be stored for a long time, the recommend condition is:*

*Temperature :        0 °C ~ 40 °C*

*Relatively humidity: ≤80%*

9.2.3 *The LCD modules should be stored in the room without acid, alkali and harmful gas.*

**9.3 *The LCD modules should be no falling and violent shocking during transportation, and also should avoid excessive press, water, damp and sunshine.***

**END**

Our company network supports you worldwide with offices in Germany, Austria, Switzerland, the UK and the USA. For more information please contact:

## Headquarters

### Germany



#### FORTEC Elektronik AG

Augsburger Str. 2b  
82110 Germering

Phone: +49 89 894450-0  
E-Mail: [info@fortecag.de](mailto:info@fortecag.de)  
Internet: [www.fortecag.de](http://www.fortecag.de)

## Fortec Group Members

### Austria



#### Distec GmbH Office Vienna

Nuschinggasse 12  
1230 Wien

Phone: +43 1 8673492-0  
E-Mail: [info@distec.de](mailto:info@distec.de)  
Internet: [www.distec.de](http://www.distec.de)

### Germany



#### Distec GmbH

Augsburger Str. 2b  
82110 Germering

Phone: +49 89 894363-0  
E-Mail: [info@distec.de](mailto:info@distec.de)  
Internet: [www.distec.de](http://www.distec.de)

### Switzerland



#### ALTRAC AG

Bahnhofstraße 3  
5436 Würenlos

Phone: +41 44 7446111  
E-Mail: [info@altrac.ch](mailto:info@altrac.ch)  
Internet: [www.altrac.ch](http://www.altrac.ch)

### United Kingdom



#### Display Technology Ltd.

Osprey House, 1 Osprey Court  
Hichingbrooke Business Park  
Huntingdon, Cambridgeshire, PE29 6FN

Phone: +44 1480 411600  
E-Mail: [info@displaytechnology.co.uk](mailto:info@displaytechnology.co.uk)  
Internet: [www.displaytechnology.co.uk](http://www.displaytechnology.co.uk)

### USA



#### Apollo Display Technologies, Corp.

87 Raynor Avenue,  
Unit 1 Ronkonkoma,  
NY 11779

Phone: +1 631 5804360  
E-Mail: [info@apolloDisplays.com](mailto:info@apolloDisplays.com)  
Internet: [www.apolloDisplays.com](http://www.apolloDisplays.com)