

# Datasheet

## Disea

ZW-T070SWH-03

DE-05-009

 APOLLO DISPLAY  
TECHNOLOGIES



**FORTEC**  
INTEGRATED



**FORTEC**  
UNITED KINGDOM



---

The information contained in this document has been carefully researched and is, to the best of our knowledge, accurate. However, we assume no liability for any product failures or damages, immediate or consequential, resulting from the use of the information provided herein. Our products are not intended for use in systems in which failures of product could result in personal injury. All trademarks mentioned herein are property of their respective owners. All specifications are subject to change without notice.

---



# PRODUCT SPECIFICATIONS

For Customer: \_\_\_\_\_

: APPROVAL FOR SPECIFICATION

Customer Model No. \_\_\_\_\_

: APPROVAL FOR SAMPLE

Module No.: ZW-T070SWH-03

Date : 2018-08-04

**Table of Contents**

No.	Item	Page
1	Cover Sheet(Table of Contents)	
2	Revision Record	
3	General Specifications	
4	Outline Drawing	
5	Absolute Maximum Ratings	
6	Electrical Specifications	
7	Optical Characteristics	
8	Reliability Test Items and Criteria	
9	Precautions for Use of LCD Modules	

**For Customer's Acceptance:**

Approved By	Comment

PREPARED	CHECKED	VERIFIED BY QA DEPT	VERIFIED BY R&D DEPT
mma	john		Dmjiaang



### 3. General Specifications

*ZW-T070SWH-03 is a TFT-LCD module. It is composed of a TFT-LCD panel, driver IC, FPC, a back light unit. The 7.0" display area contains 800x480 pixels and can display up to 16.7M colors. This product accords with RoHS environmental criterion.*

Item	Contents	Unit	Note
LCD Type	TFT	-	
Display color	16.7M		
Viewing Direction	12	O'Clock	
Gray scale inversion direction	6	O'Clock	
Operating temperature	-20~+70	°C	
Storage temperature	-30~+80	°C	
Module size	Refer to outline drawing	mm	
Active Area(W×H)	154.08X85.92	mm	
Number of Dots	800×480	dots	
Controller	EK9713CA01/EK73002ACGB-01	-	
Power Supply Voltage	3.3	V	
Outline Dimensions	Refer to outline drawing	-	
Backlight	3X9-LEDs (white)	pcs	
Weight	---	g	
Interface	RGB888	-	

## 4.Outline.Drawing

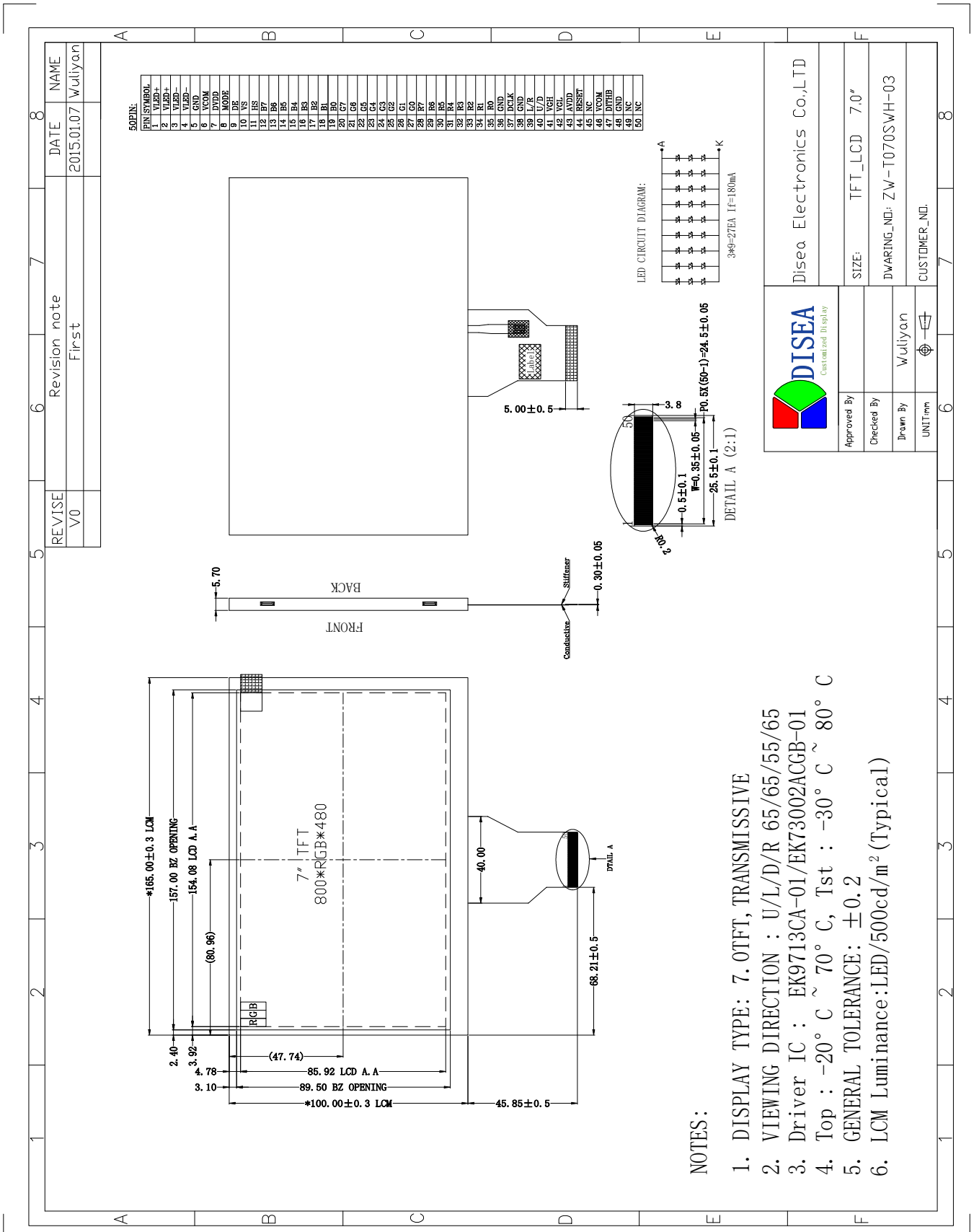

## 5. Absolute Maximum Ratings( $T_a=25^\circ\text{C}$ )

### 5.1 Electrical Absolute Maximum Ratings.( $V_{SS}=0\text{V}$ , $T_a=25^\circ\text{C}$ )

Item	Symbol	Min.	Max.	Unit	Note
Power Supply Voltage	DVDD	-0.3	5.0	V	1, 2
	AVDD	6.5	13.5		
	VGH	-0.3	40.0		
	VGL	-20	0.3		
	$V_{GH}-V_{GL}$	-	40.0		

Notes:

1. If the module is above these absolute maximum ratings. It may become permanently damaged. Using the module within the following electrical characteristic conditions are also exceeded, the module will malfunction and cause poor reliability.
2.  $V_{DVDD} > V_{SS}$  must be maintained.
3. Please be sure users are grounded when handing LCD Module.

### 5.2 Typical operation conditions

Item	Symbol	Values			Unit	Remark
		Min.	Typ.	Max.		
Power voltage	DVDD	3.0	3.3	3.6	V	
	AVDD	10.2	10.4	10.6	V	
	VGH	15.3	16	16.7	V	
	VGL	-7.7	-7.0	-6.3	V	
Input signal voltage	VCOM	2.8	3.8	4.8	V	

### 5.3 Environmental Absolute Maximum Ratings.

Item	Storage		Operating		Note
	MIN.	MAX.	MIN.	MAX.	
Ambient Temperature	-30°C	80°C	-20°C	70°C	1,2
Humidity	-	-	-	-	3

1. *The response time will become lower when operated at low temperature.*
2. *Background color changes slightly depending on ambient temperature.*

*The phenomenon is reversible.*

3. *T<sub>a</sub> ≤ 40 °C: 85%RH MAX.*

*T<sub>a</sub> > 40 °C: Absolute humidity must be lower than the humidity of 85%RH at 40 °C.*

## 6. Electrical Specifications and Instruction Code

### 6.1 Electrical characteristics ( $V_{SS}=0V, T_a=25^\circ C$ )

Parameter	Symbol	Condition	Min	Typ	Max	Unit	Note	
Power supply	DVDD	$T_a=25^\circ C$	3.0	3.3	3.6	V		
Input signal voltage	VCOM	$T_a=25^\circ C$	2.8	-	4.8	V		
Input voltage	'H'	$V_{IH}$	DVDD=3.3V	0.7DVDD	-	DVDD	V	
	'L'	$V_{IL}$	DVDD=3.3V	0	-	0.3DVDD	V	
Current Consumption	$I_{DVDD1}$	Normal mode	-	-	-	mA	2	
	$I_{DVDD2}$	Sleep mode	-	-	-	mA	2	
Clock Frequency	$f_{CLK}$	-	-	-	-	MHz		

Note: 1: Tested in 1x1 chessboard pattern.

### 6.2 LED backlight specification ( $V_{SS}=0V, T_a=25^\circ C$ )

Item	Symbol	Condition	Min	Typ	Max	Unit	Note
Supply voltage	$V_f$	$I_f=9 \times 20mA$	-	9.0	-	V	
Uniformity	$\Delta Bp$	$I_f=9 \times 20mA$	75	-	-	%	

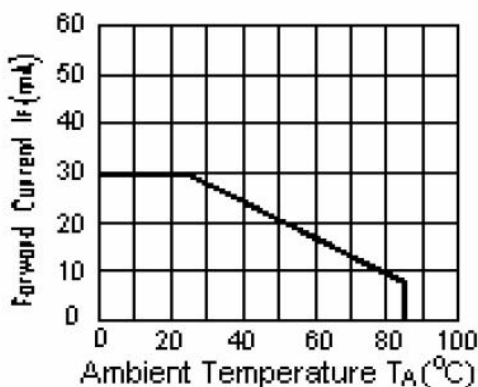

ILED VS TEMP



## 6.3 Interface signals

Pin No.	Symbol	I/O	Function
1-2	VLED+	P	LED back light(Anode)
3-4	VLED-	P	LED back light(Cathode)
5	GND	P	Ground.
6	VCOM	P	Commom voltage
7	DVDD	P	Power supply
8	MODE	I	DE/YSNC mode select
9	DE	I	Data enable pin
10	VS	I	Frame sync signal
11	HS	I	Line sync signal
12-19	B7~B0	I	Blue data bus
20-27	G7~G0	I	Green data bus
28-35	R7~R0	I	Red data bus
36	GND	P	Ground.
37	DCLK	I	Data clock
38	GND	P	Ground.
39	L/R	I	Right/Left sequence control of source driver
40	U/D	I	Gate driver Up/Down scan control of gate driver
41	VGH	P	Gate on voltage
42	VGL	P	Gate off voltage
43	AVDD	P	power for analog circuit
44	RESET	I	Reset the display
45	NC	-	No connection.
46	VCOM	P	Commom voltage
47	DITHB	I	Dithering function enable control. Normally pull high. DITHB=1, enable disable internal dithering function. DITHB =0,disable internal dithering function.
48	GND	P	Ground
49-50	NC	-	No connection.

## 6.4 Timing

### •Horizontal input timing

Parameter		Symbol	Value			Unit
Horizontal display area		thd	800			DCLK
DCLK frequency		fclk	Min.	Typ.	Max.	MHz
			-	33.3	50	
1 Horizontal Line		th	862	1056	1200	DCLK
HSD pulse width	Min.	thpw	1			
	Typ.		-			
	Max.		40			
HSD Back Porch (Blanking)		thb	46	46	46	
HSD Front Porch		thfp	16	210	354	

### •Vertical input timing

Parameter	Symbol	Min.	Typ.	Max.	Unit
Vertical display area	tvd	480			H
VSD period time	tv	510	525	650	H
VSD pulse width	tpw	1	-	20	H
VSD Back Porch (Blanking)	tvb	23	23	23	H
VSD Front Porch	tvfp	7	22	147	H

## 6.5 AC Characteristics

Parameter	Symbol	Condition	Min.	Typ.	Max.	Unit
VDD Power On Slew rate	TPOR	From 0V to 90% VDD	-	-	20	ms
RSTB pulse width	TRST	CLKIN = 40MHz	1	-	-	ms
CLKIN cycle time	Tcph	-	20	-	-	ns
CLKIN pulse duty	Tcwh	-	40	50	60	%
VSD setup time	Tvst	-	8	-	-	ns
VSD hold time	Tvhd	-	8	-	-	ns
HSD setup time	Thst	-	8	-	-	ns
HSD hold time	Thhd	-	8	-	-	ns
Data set-up time	Tdsu	D0[7:0], D1[7:0], D2[7:0] to CLKIN	8	-	-	ns
Data hold time	Tdhd	D0[7:0], D1[7:0], D2[7:0] to CLKIN	8	-	-	ns
DEN setup time	Tesu	-	8	-	-	ns
DEN hold time	Tehd	-	8	-	-	ns
Output stable time	Tsst	10% to 90% target voltage. CL=120pF, R=10K ohm	-	-	6	us

### •Parallel 24-bit RGB Mode

Parameter	Symbol	Condition	Min.	Typ.	Max.	Unit
CLKIN Frequency	fclk	VDD = 3.0V ~3.6V	-	33.3	50	MHz
CLKIN Cycle Time	Tclk	-	20	30	-	ns
CLKIN Pulse Duty	Tcwh	Tclk= Tcwh + cwl	40	50	60	%
	Tcwl		40	50	-60	%
VSD to STV	Tstv	HV mode	-	24	-	H
DEN to STV	Tstv	DE mode	-	4	-	CLKIN
STV pulse width	Twstv	-	-	0.5	-	H
STV to CKV	Tckv	-	-	18	-	CLKIN
STV to OEV	Toev	-	-	2	-	CLKIN
CKV Pulse Width	Twckv	-	-	66	-	CLKIN
OEV Pulse Width	Twoev	-	-	50	-	CLKIN

## 6.6 Data Input format

### a. Horizontal Timing

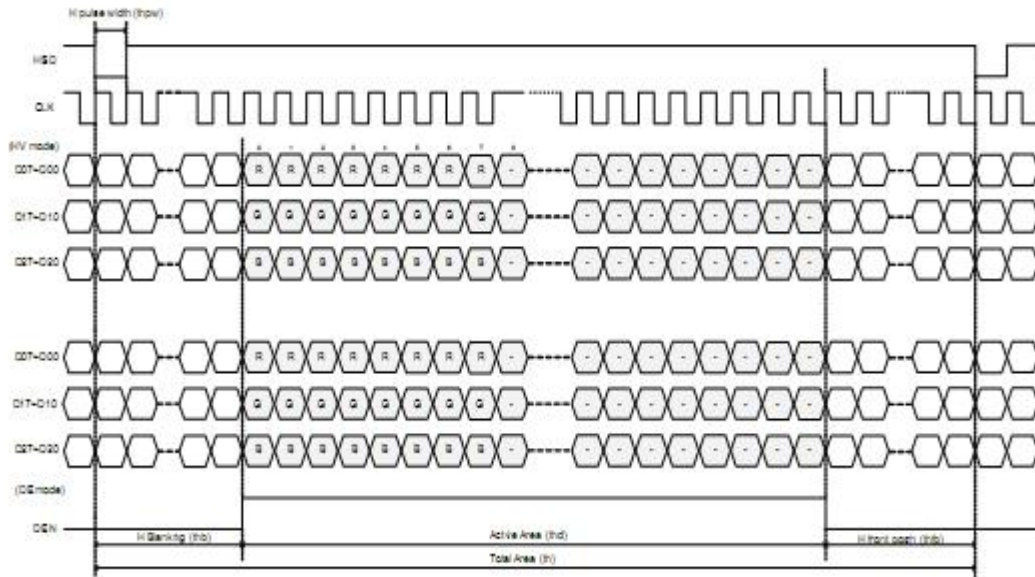

### b. Vertical Timing

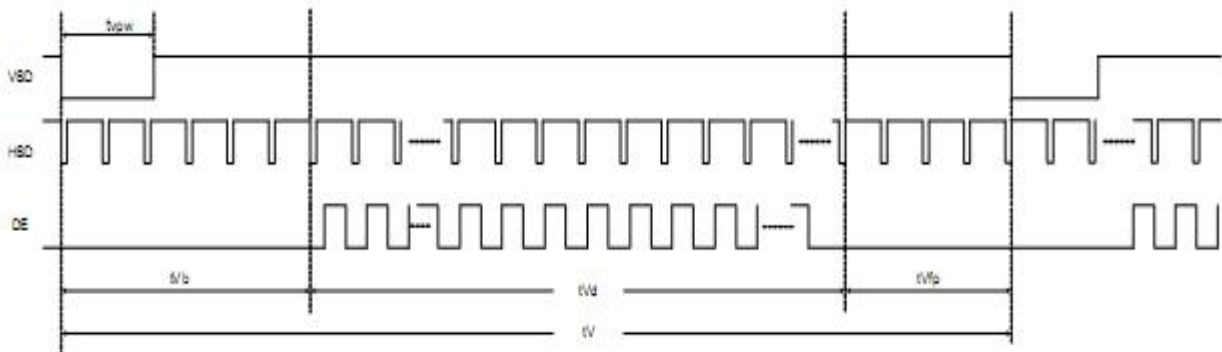

## 6.7 Timing diagram

### 6.7.1 Input clock and data timing waveform

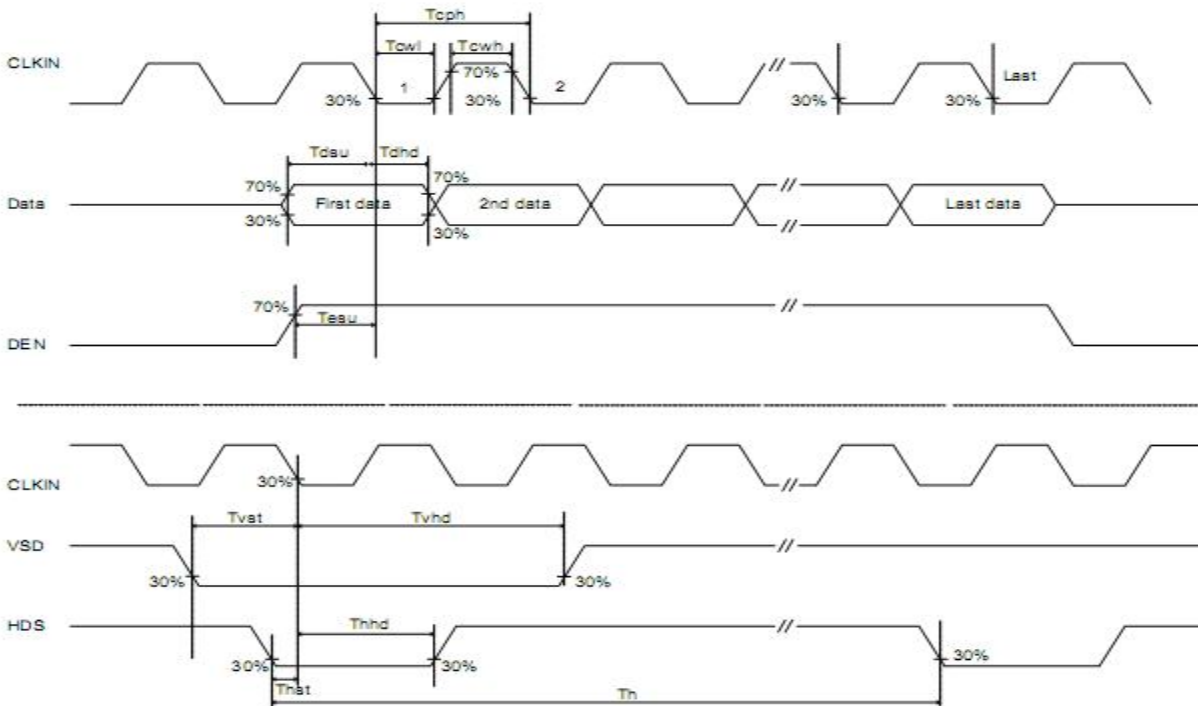

### 6.7.2 Output load condition

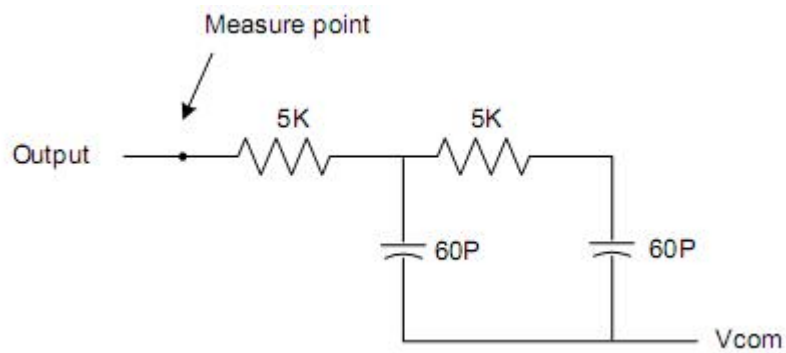

## 7. Optical Characteristics

Item	Symbol	Condition	Min.	Typ.	Max.	Unit	Note	
Brightness	Bp	$\theta=0^\circ$	-	500	-	Cd/m <sup>2</sup>	1	
Uniformity	$\Delta Bp$	$\Phi=0^\circ$	75	-	-	%	1,2	
Viewing Angle	3:00	Cr $\geq$ 10	-	65	-	Deg	3	
	6:00		-	55	-			
	9:00		-	65	-			
	12:00		-	65	-			
Contrast Ratio	Cr	$\theta=0^\circ$ $\Phi=0^\circ$	400	500	-	-	4	
Response Time	T <sub>r</sub>		-	10	20	ms	5	
	T <sub>f</sub>		-	15	30	ms		
Color of CIE Coordinate ( $\pm 0.03$ )	W	x		0.308		-	1,6	
		y		0.347		-		
	R	x		0.583		-		
		y		0.328		-		
	G	x	$\theta=0^\circ$ $\Phi=0^\circ$		0.303			-
		y			0.554			-
	B	x			0.144			-
		y			0.113			-
NTSC Ratio	S			-	-	-	%	

Note: The parameter is slightly changed by temperature, driving voltage and materiel

Note 1: The data are measured after LEDs are turned on for 5 minutes. LCM displays full white. The brightness is the average value of 9 measured spots. Measurement equipment BM-7 ( $\Phi 5\text{mm}$ )

Measuring condition:

- Measuring surroundings: Dark room.
- Measuring temperature: Ta=25 °C.
- Adjust operating voltage to get optimum contrast at the center of the display.

Measured value at the center point of LCD panel after more than 5 minutes while backlight turning on.

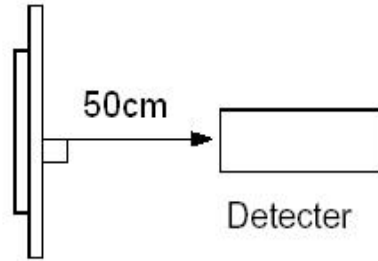

Note 2: The luminance uniformity is calculated by using following formula.

$$\Delta Bp = Bp (\text{Min.}) / Bp (\text{Max.}) \times 100 (\%)$$

$Bp (\text{Max.})$  = Maximum brightness in 9 measured spots

$Bp (\text{Min.})$  = Minimum brightness in 9 measured spots.

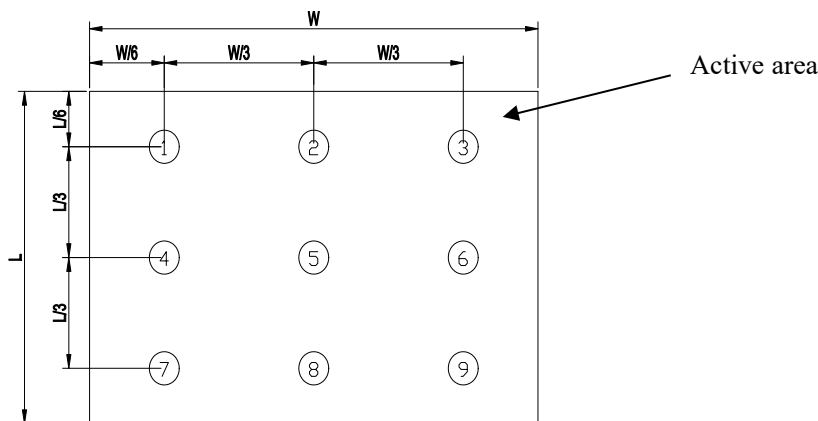

Note 3: The definition of viewing angle:

Refer to the graph below marked by  $\vartheta$  and  $\phi$

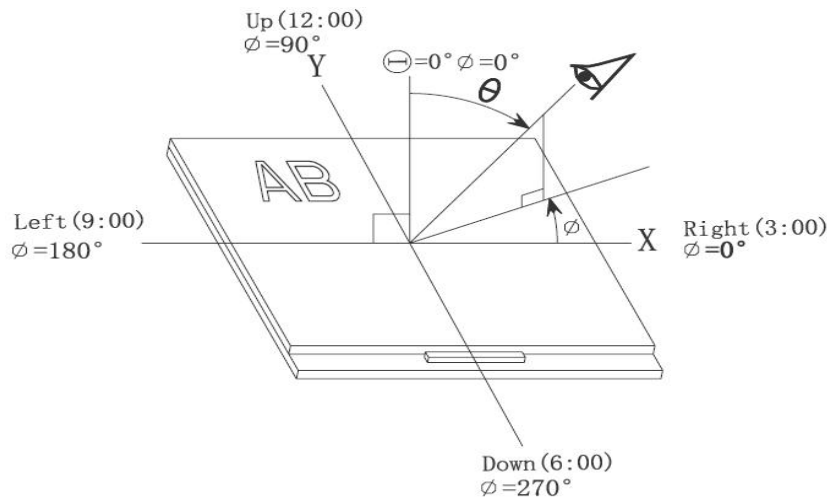

Note 4: Definition of contrast ratio.( Test LCD using DMS501)

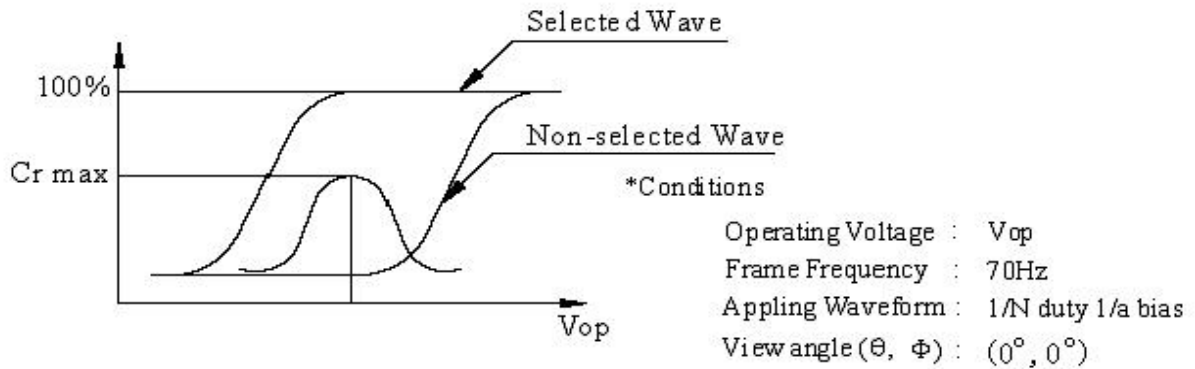

$$\text{Contrast ratio}(Cr) = \frac{\text{Brightness of selected dots}}{\text{Brightness of non-selected dots}}$$

Note 5: Definition of Response time. (Test LCD using DMS501):

The output signals of photo detector are measured when the input signals are changed from “black” to “white”(falling time) and from “white” to “black”(rising time), respectively. The response time is defined as the time interval between the 10% and 90% of amplitudes.Refer to figure as below.

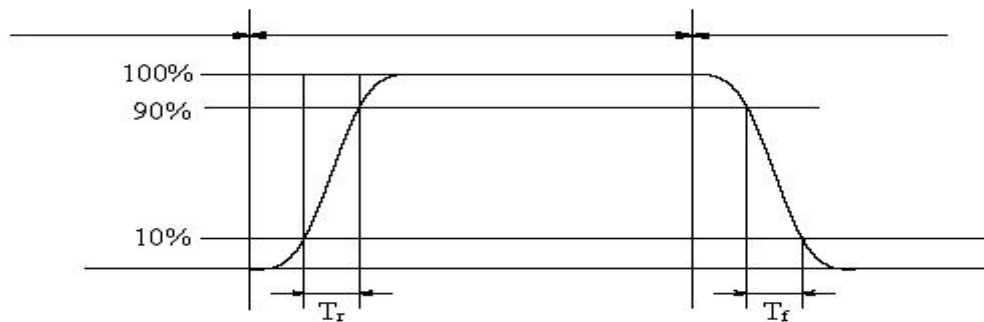

The definition of response time

Note 6: Definition of Color of CIE Coordinate and NTSC Ratio.

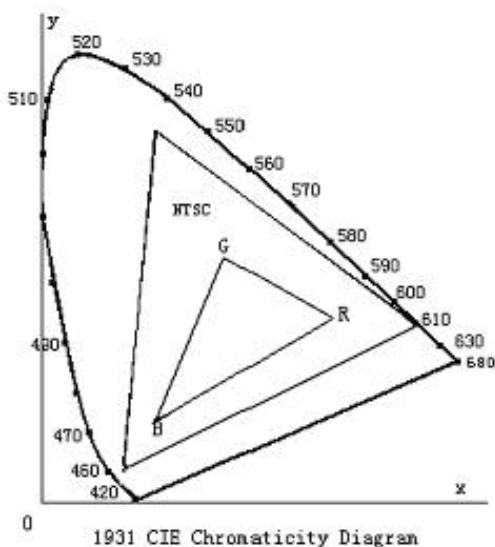

**Color gamut:**

$$S = \frac{\text{area of RGB triangle}}{\text{area of NTSC triangle}} \times 100\%$$

Note 7: Definition of cross talk.

Cross talk ratio(%)=|pattern A Brightness-pattern B Brightness|/pattern A Brightness\*100

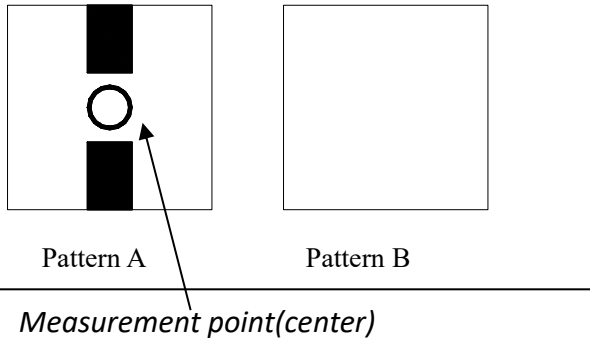

Electric volume value=3F+/-3Hex



## 8. Reliability Test Items and Criteria

No	Test Item	Test condition	Criterion
1	High Temperature Storage	80°C±2°C 96H Restore 2H at 25°C Power off	1. After testing, cosmetic and electrical defects should not happen. 2. Total current consumption should not be more than twice of initial value.
2	Low Temperature Storage	-30°C±2°C 96H Restore 2H at 25°C Power off	
3	High Temperature Operation	70°C±2°C 96H Restore 2H at 25°C Power on	
4	Low Temperature Operation	-20°C±2°C 96H Restore 4H at 25°C Power on	
5	High Temperature/Humidity Operation	60°C±2°C 90%RH 96H Power on	
6	Temperature Cycle	-30°C —————> 80°C  30min 5min 30min  after 5 cycle, Restore 2H at 25°C Power off	

Note: Operation: Supply 3.3V for logic system.

The inspection terms after reliability test, as below

ITEM	Inspection
Contrast	CR>50%
IDD	IDD<200%
Brightness	Brightness>60%
Color Tone	Color Tone+/-0,05

## **9. Precautions for Use of LCD Modules**

### **9.1 Handling Precautions**

9.1.1 *The display panel is made of glass. Do not subject it to a mechanical shock by dropping it from a high place, etc.*

9.1.2 *If the display panel is damaged and the liquid crystal substance inside it leaks out, be sure not to get any in your mouth, if the substance comes into contact with your skin or clothes, promptly wash it off using soap and water.*

9.1.3 *Do not apply excessive force to the display surface or the adjoining areas since this may cause the color tone to vary.*

9.1.4 *The polarizer covering the display surface of the LCD module is soft and easily scratched. Handle this polarizer carefully.*

9.1.5 *If the display surface is contaminated, breathe on the surface and gently wipe it with a soft dry cloth. If still not completely clear, moisten cloth with one of the following solvents:*

— Isopropyl alcohol                      — Ethyl alcohol

*Solvents other than those mentioned above may damage the polarizer. Especially, do not use the following:*

— Water                                      — Ketone                                      — Aromatic solvents

9.1.6 *Do not attempt to disassemble the LCD Module.*

9.1.7 *If the logic circuit power is off, do not apply the input signals.*

9.1.8 *To prevent destruction of the elements by static electricity, be careful to maintain an optimum work environment.*

*a. Be sure to ground the body when handling the LCD Modules.*

*b. Tools required for assembly, such as soldering irons, must be properly ground.*

*c. To reduce the amount of static electricity generated, do not conduct assembly and other work under dry conditions.*

*d. The LCD Module is coated with a film to protect the display surface. Be care when peeling off this protective film since static electricity may be generated.*

## **9.2 Storage precautions**

9.2.1 *When storing the LCD modules, avoid exposure to direct sunlight or to the light of fluorescent lamps.*

9.2.2 *The LCD modules should be stored under the storage temperature range. If the LCD modules will be stored for a long time, the recommend condition is:*

*Temperature :        0 °C ~ 40 °C*

*Relatively humidity: ≤80%*

9.2.3 *The LCD modules should be stored in the room without acid, alkali and harmful gas.*

**9.3 *The LCD modules should be no falling and violent shocking during transportation, and also should avoid excessive press, water, damp and sunshine.***

**END**

Our company network supports you worldwide with offices in Germany, Austria, Switzerland, the UK and the USA.  
For more information please contact:

## Headquarters

Germany



**FORTEC**  
GROUP

**FORTEC Elektronik AG**  
Augsburger Str. 2b  
82110 Germering

Phone: +49 89 894450-0  
E-Mail: [info@fortecag.de](mailto:info@fortecag.de)  
Internet: [www.fortecag.de](http://www.fortecag.de)

---

## Fortec Group Members

Austria



**FORTEC**  
INTEGRATED

**FORTEC Integrated GmbH Office Vienna**  
Nuschinggasse 12  
1230 Wien

Phone: +43 1 8673492-0  
E-Mail: [info@fortec-integrated.de](mailto:info@fortec-integrated.de)  
Internet: [www.fortec-integrated.de](http://www.fortec-integrated.de)

Germany



**FORTEC**  
INTEGRATED

**FORTEC Integrated GmbH**  
Augsburger Str. 2b  
82110 Germering

Phone: +49 89 894363-0  
E-Mail: [info@fortec-integrated.de](mailto:info@fortec-integrated.de)  
Internet: [www.fortec-integrated.de](http://www.fortec-integrated.de)

Switzerland



**FORTEC**  
SWITZERLAND

**FORTEC Switzerland AG**  
Bahnhofstraße 3  
5436 Würenlos

Phone: +41 44 7446111  
E-Mail: [info@fortec.ch](mailto:info@fortec.ch)  
Internet: [www.fortec.ch](http://www.fortec.ch)

United Kingdom



**FORTEC**  
UNITED KINGDOM

**FORTEC Technology UK Ltd.**  
Osprey House, 1 Osprey Court  
Hinchingbrooke Business Park  
Huntingdon, Cambridgeshire, PE29 6FN

Phone: +44 1480 411600  
E-Mail: [info@fortec.uk](mailto:info@fortec.uk)  
Internet: [www.fortec.uk](http://www.fortec.uk)

USA



 **APOLLO DISPLAY  
TECHNOLOGIES**  
A FORTEC GROUP MEMBER

**Apollo Display Technologies, Corp.**  
87 Raynor Avenue, Unit 1  
Ronkonkoma, NY 11779

Phone: +1 631 5804360  
E-Mail: [info@apolloDisplays.com](mailto:info@apolloDisplays.com)  
Internet: [www.apolloDisplays.com](http://www.apolloDisplays.com)