



OUR GLOBAL  
COMPETENCE  
CENTRES

 APOLLO DISPLAY  
TECHNOLOGIES



 DISTEC



 DISPLAY  
TECHNOLOGY



# Datasheet

## Distec

DD-0700!A C01

88 !\$/4\$\$7

**PRODUCT SPECIFICATIONS(Preliminary)**

For Customer: \_\_\_\_\_

: APPROVAL FOR SPECIFICATION

Customer Model No. \_\_\_\_\_

: APPROVAL FOR SAMPLE

Module No.: DD-0700-MC01

Date : 2021-06-24

**Table of Contents**

No.	Item	Page
1	Cover Sheet(Table of Contents)	P3
2	Revision Record	P4
3	General Specifications	P5
4	Outline Drawing	P6
5	Absolute Maximum Ratings	P7
6	Electrical Specifications	P8
7	Optical Characteristics	P19
8	Reliability Test Items and Criteria	P23
9	Precautions for Use of LCD Modules	P24

**For Customer's Acceptance:**

Approved By	Comment

PREPARED	CHECKED	VERIFIED BY QA DEPT	VERIFIED BY R&D DEPT
LC			

## 2. Revision Record

Date	Rev.No.	Page	Revision Items	Prepared
2020.07.13	V0		The first release	CJ
2020.07.23	V1		Updated Luminance in Item6,Item#7 and Item#8	CJ
2020.08.01	V2		Updated Item3,Item#6.3.1,6.3.2 and Item#8	CJ
2020.08.05	V3		Updated the Surface treatment in Item#3	CJ
2021.03.25	V4		Updated supply current in Item#6.2 and Luminance in Item#7	CS
2021.04.08	V5		Updated surface treatment in Item3	CS
2021.05.25	V6		Updated Module size in Item3 and Drawing in item 4	CS
2021.06.24	V7	22	Updated Note 6 with color gamut comparison to Mitsubishi AA070MC01	TR
2021.07.12	V8		Added UL No. in Item #3	CS
2021.07.14	V9		Drawing in Item #4	CS
2021.09.14	V10		Updated luminance in Item #7	CS
2021.12.21.	V11		Updated UL No. in Item #3	CS
2023.01.16.	V12		Updated scan direction in Item #6.3.1	CS

### 3. General Specifications

*DD-0700-MC01 is a 7.0" color TFT-LCD (Thin Film Transistor Liquid Crystal Display) module composed of LCD panel, driver ICs, control circuit, LED driver and backlight unit. The display area contains 800X(RGB)x480 pixels and can display up to 16.7M colors.*

*This product is RoHS compliant. UL No. 62368-1*

Item	Contents	Unit	Note
LCD Type	TFT	-	
Display color	16.7M		1
Viewing Direction	ALL	O'Clock	
Display Mode	Transmissive, Normally Black		
Operating temperature	-30~+80	°C	
Storage temperature	-30~+80	°C	
Module size	169.8X109.70X9	mm	2
Active Area(W×H)	152.40X91.44	mm	
Number of Dots	800×480	dots	
TFT Driver IC	HX8290-A-LT, HX8664-B-LT	-	
Power Supply Voltage	3.3	V	
Weight	-	g	
Interface	LVDS	-	
Surface treatment	Clear/Glare and hard-coating 3H		

*Note 1: Color tune is slightly changed by temperature and driving voltage.*

*Note 2: Without FPC and Solder.*

4.Outline.Drawing

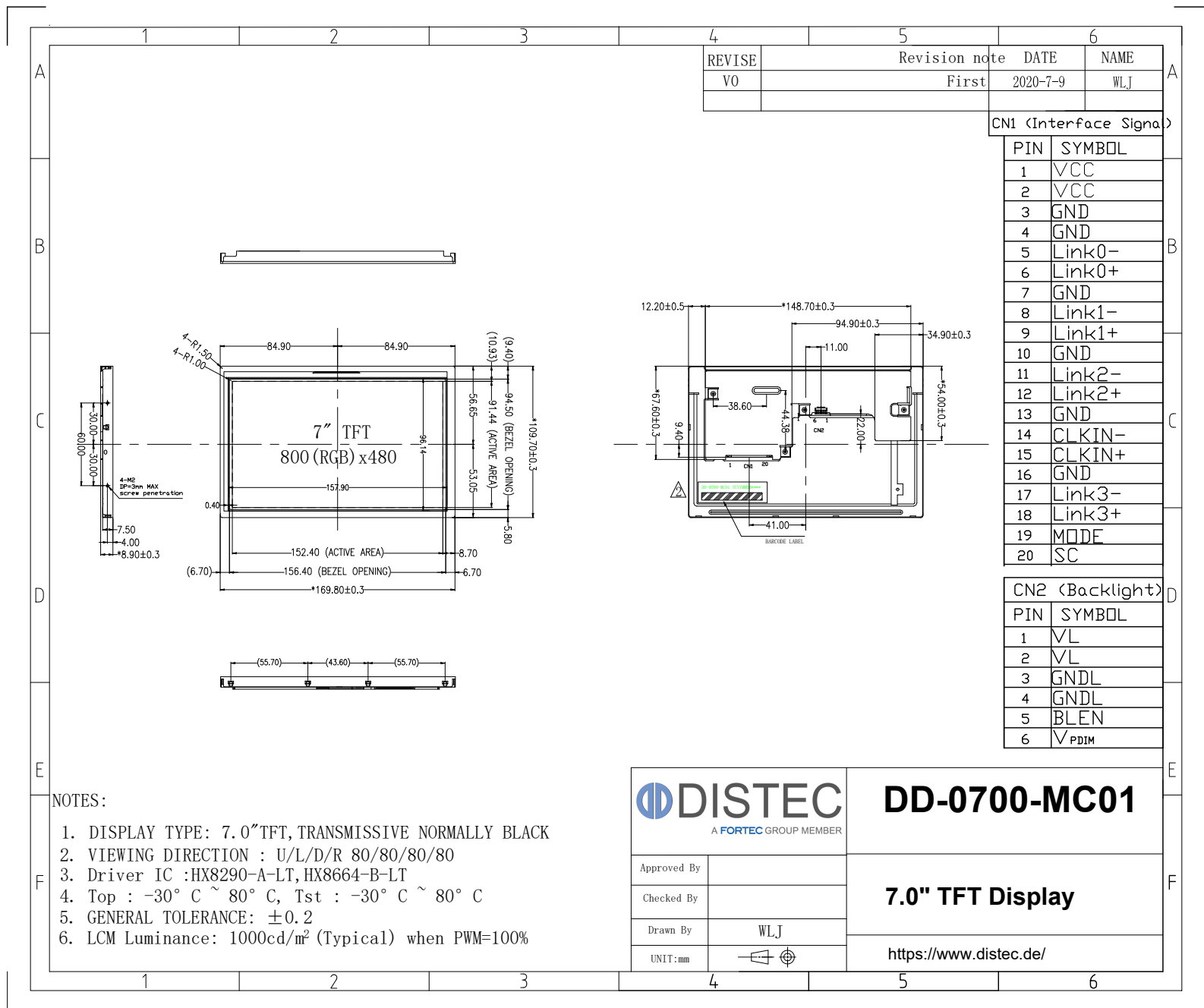

### 5. Absolute Maximum Ratings( $T_a=25\text{ }^\circ\text{C}$ )

#### 5.1 Electrical Absolute Maximum Ratings.( $V_{SS}=0\text{V}$ , $T_a=25\text{ }^\circ\text{C}$ )

Item	Symbol	Min.	Max.	Unit	Note
Power Supply Voltage	VCC	-0.3	4.0	V	1, 2
	VL	-0.3	14.0	V	1, 2
	VPDIM	-0.3	14.0	V	1, 2
	BLEN	-0.3	14.0	V	1, 2

**Notes:**

1. If the module is used above these absolute maximum ratings, it may become permanently damaged. Using the module out of the indicated electrical range may cause malfunction and poor reliability.
2.  $V_{CC} > V_{SS}$  must be maintained.
3. Please make sure users are grounded when handing LCD Module.

#### 5.2 Environmental Absolute Maximum Ratings.

Item	Storage		Operating		Note
	MIN.	MAX.	MIN.	MAX.	
Ambient Temperature	-30 $^\circ\text{C}$	80 $^\circ\text{C}$	-30 $^\circ\text{C}$	80 $^\circ\text{C}$	1,2
Humidity	-	-	-	-	3

**Notes:**

1. The response time will become lower when operated at low temperature.
2. Background color changes slightly depending on ambient temperature.  
The phenomenon is reversible.
3.  $T_a \leq 40\text{ }^\circ\text{C}$ : 85%RH MAX.  
 $T_a > 40\text{ }^\circ\text{C}$ : Absolute humidity must be lower than the humidity of 85%RH at 40 $^\circ\text{C}$ .

### 6. Electrical Specifications

#### 6.1 Electrical characteristics( $V_{SS}=0V, T_a=25^\circ C$ )

Parameter	Symbol	Condition	Min	Typ	Max	Unit	Note
Power supply	VCC	$T_a=25^\circ C$	3.0	3.3	3.6	V	
Backlight Power supply	VL	$T_a=25^\circ C$	9	12.0	13.2	V	
Input voltage	'H'	$V_{IH}$	$T_a=25^\circ C$	0.7VCC	-	VCC	V
	'L'	$V_{IL}$	$T_a=25^\circ C$	-0.3	-	0.3VCC	V
Current of power supply	ICC	$T_a=25^\circ C$	-	100	-	mA	

#### 6.2 LED backlight specification( $V_{SS}=0V, T_a=25^\circ C$ )

Item	Symbol	Min	Typ	Max	Unit	Note
Supply voltage	VL	9	12.0	13.2	V	
Supply Current	IL	-	380*	-	mA	(VL=12V) PWM=100%
Power Consumption	PL	-	4.2	-	W	(VL=12V) PWM=100%
PWM Control Frequency	$F_{PDIM}$	100	-	30K	Hz	
Dimming Ratio (PWM Duty)	DR	1	-	100	%	2
Backlight ON-OFF	High	BLEN	1.6	-	VL	V
	Low		0	-	0.8	V
PWM Control Level	High	$V_{PDIM}$	1.6	-	VL	V
	Low		0	-	0.8	V
Uniformity	$\Delta Bp$	75	80	-	%	
Life Time	time	-	50K	-	hours	1

\* @1000cd/m<sup>2</sup>

**Notes:**

1. The lifetime of LED is defined as the time when it continues to operate under the conditions at  $T_a = 25 \pm 2^\circ C$  and  $I_{LED} = 50mA$  (LED forward current) until the brightness becomes  $\leq 50\%$  of its original value.



2. Lower frequency causes the flicker or the image breaking of motion picture. Depending on the PDIM signal integrity (jitter etc.), the flicker may be visible. Please evaluate in advance.

3. Please note that LED life will be shorter than the average life described in the specification if operate in higher ambient temperature.

### 6.3.1 CN 1(Interface Signal)

Used connector: 20186-020E-11F(I-PEX) or FI-SEB20P-HFE (JAE)

Corresponding connector: 20197- 20U-F (I-PEX) or FI-S20S[for discrete Wire],

FI-SE20ME[for FPC] (JAE)

Pin No.	Symbol	I/O	Function	
1-2	VCC	P	Power supply	
3-4	GND	P	Ground.	
5	LINK0-	I	LVDS lane0 input	
6	LINK0+	I		
7	GND	P	Ground.	
8	LINK1-	I	LVDS lane1 input	
9	LINK1+	I		
10	GND	P	Ground.	
11	LINK2-	I	LVDS lane2 input	
12	LINK2+	I		
13	GND	P	Ground.	
14	CLKIN-	I	LVDS CLK input	
15	CLKIN+	I		
16	GND	P	Ground.	
17	LINK3-	I	LVDS lane3 input	
18	LINK3+	I		
19	MODE	I	MODE=1	LVDS 8 BIT (High or NC)
			MODE=0	LVDS 6 BIT (Low or GND)
20	SC	I	Scan direction control (Low=Normal, High=Reverse) *	

\* scan direction opposite to DD-0700-ME01 and AA070ME01

## 6.3.2 CN 2(Backlight)

Backlight-side connector: FI-S6P-HFE (JAE)

Corresponding connector: FI-S6S (JAE)

Pin No.	Symbol	I/O	Function
1-2	VL	P	Power supply For BL.
3-4	GND	P	Ground.
5	BLEN	I	LED driver enable input
6	VPDIM	I	PWM dimming control input.

## 6.4 AC Characteristics

### 6.4.1 For the digital circuit: LVDS mode

Parameter	Symbol	Condition	Spec.			Unit
			Min.	Typ.	Max.	
Differential input high Threshold voltage	$V_{th}$	$V_{cm}=1.2V$	-	-	+0.1	V
Differential input low threshold voltage	$V_{tl}$	-	-0.1	-	-	V
Differential input common Mode voltage	$V_{CM}$	-	1	1.2	$1.7- V_{id} /2$	V
LVDS input voltage	$V_{INLV}$	-	0.7	-	1.7	V
Differential input voltage	$ V_{id} $	-	0.1	-	0.6	V
Differential input leakage Current	$I_{lvleak}$	-	-10	-	+10	$\mu A$

**Single-ended:**  
 LVCLKP (R),  
 LVCLKN (R),  
 LVD [3:0]P (R),  
 LVD [3:0]N (R)

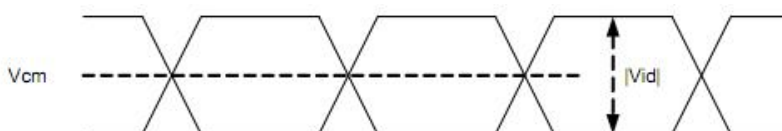

**Differential:**  
 LVCLKP (R)-LVCLKN (R),  
 LVD [3:0]P (R)-  
 LVD [3:0]N (R)

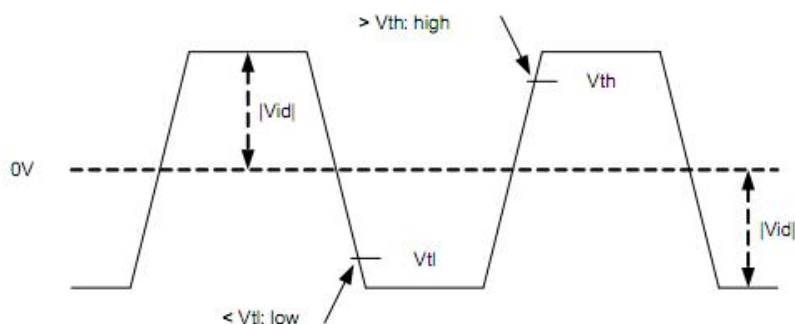

### 6.4.2 For the analog circuit: Normal mode

Parameter	Symbol	Conditions	Spec.			Unit
			Min.	Typ.	Max.	
Analog positive supply voltage	VSP	VSP is generated by PFM, VSPS [4:0]=14h, with proper settings and components.	6.7	7	7.3	V
Analog negative supply voltage	VSN	VSN is generated by PFM, VSNS [4:0]=14h, with proper settings and components.	-7.3	-7	-6.7	V
Source driver positive supply voltage	VSDP	VSP $\geq$ 7V, VSDPS[4:0]=14h, loading current=0	6.65	6.8	6.95	V
Source driver negative supply voltage	VSDN	VSN = -7V, VSDNS[4:0]=14h, loading current=0	-6.95	-6.8	-6.65	V
Output for positive gamma reference high voltage	VGMPHO	VSDP $\geq$ 6.8V, VGMPHS[4:0]=0x1Ah	6.48	6.6	6.72	V
Output for positive gamma reference voltage	VGMPMO	VSDP $\geq$ 6.8V, VGMPHS[4:0]=0x1Ah, VGMPHS[3:0]=0x00h	3.3	3.4	3.5	V

Output for positive gamma reference low voltage	VGMPLO	VGMPHS[3:0]=0x00h	0.12	0.2	0.28	V
Output for negative gamma reference high voltage	VGMNHO	VSDN $\leq$ -6.8V, VGMNHS[4:0]=0x1Ah	-6.72	-6.6	-6.48	V
Output for negative gamma reference voltage	VGMNMO	VSDN $\leq$ -6.8V, VGMNHS[4:0]=0x1Ah, VGMNLS[4:0]=0x00h	-3.5	-3.4	-3.3	V
Output for negative gamma reference low voltage	VGMNLO	VGMNLS[4:0]=0x00h	-0.28	-0.2	-0.12	V
VCOM voltage	VCOM	VCOMS[7:0]=0x80h	-1.53	-1.48	-1.43	V
Source output voltage, positive polarity	V <sub>SDOP</sub>	-	0.2	-	VSDP-0.2	V
Source output voltage, negative polarity	V <sub>SDON</sub>	-	VSDN+0.2	-	-0.2	V
Positive power supply	VGH	VGH is generated by charge pump, VGHS[3:0]=0x05h, loading current=0	14.6	15.6	16.6	V
Negative power supply	VGL	VGL is generated by charge pump, VGLS[2:0]=0x02h, loading current=0	-11	-10	-9	V

Parameter	Symbol	Conditions	Spec.			Unit
			Min.	Typ.	Max.	
Source output voltage deviation	$V_{OD}$	$V_{SDOP}=0.5V$ to $V_{SDP}-0.5V$ , $V_{SDON}=V_{SDN}+0.5V$ to $-0.5V$	-	-	10	mV
		$V_{SDOP}=0.2V$ to $0.5V$ or $V_{SDOP}=V_{SDP}-0.5V$ to $V_{SDP}-0.2V$ , $V_{SDON}=V_{SDN}+0.2V$ to $V_{SDN}+0.5V$ or $V_{SDON}=-0.5V$ to $-0.2V$	-	-	15	mV
Standby current ( $VCC1 + VCC2$ )	$I_{STBVCC}$	"STBYB=0" and all inputs are default.	-	-	100	$\mu A$
Standby current ( $VSN$ or $VSP$ )	$I_{STB}$	"STBYB=0", $VSP$ or $VSN$ external input	-	-	100	$\mu A$

### 6.4.3 LVDS mode AC electrical characteristics

Parameter	Symbol	Spec.			Unit
		Min.	Typ.	Max.	
Clock frequency	$F_{LVCCYC}$	20	-	85	MHz
Clock period	$T_{LVCCYC}$	11.76	-	-	ns
1 data bit time	UI	-	1/7	-	$T_{LVCCYC}$
Clock high time	$T_{LVCH}$	2.8	4	4.2	UI
Clock low time	$T_{LVCL}$	2.8	3	4.2	UI
Position 1	$T_{POS1}$	-0.2	0	0.2	UI
Position 0	$T_{POS0}$	0.8	1	1.2	UI
Position 6	$T_{POS6}$	1.8	2	2.2	UI
Position 5	$T_{POS5}$	2.8	3	3.2	UI
Position 4	$T_{POS4}$	3.8	4	4.2	UI
Position 3	$T_{POS3}$	4.8	5	5.2	UI
Position 2	$T_{POS2}$	5.8	6	6.2	UI
Input eye width	$T_{EYEW}$	0.6	-	-	UI
Input eye border	$T_{EX}$	-	-	0.2	UI
LVDS wake up time	$T_{ENLVDS}$	-	-	150	us

### LVDS with SSC

Parameter	Symbol	Condition	Spec.			Unit
			Min.	Typ.	Max	
Modulation Frequency	SSC <sub>MF</sub>	LVDS clock frequency center at 80MHz	-	-	200	KHz
		LVDS clock frequency center at 60MHz	-	-	150	KHz
		LVDS clock frequency center at 40MHz	-	-	100	KHz
		LVDS clock frequency center at 20MHz	-	-	50	KHz
Modulation Rate	SSC <sub>MR</sub>	LVDS clock frequency + SSCMR in the range of 20MHz~85MHz	-	-	±5	%

### 6.4.4 TTL mode AC electrical characteristics

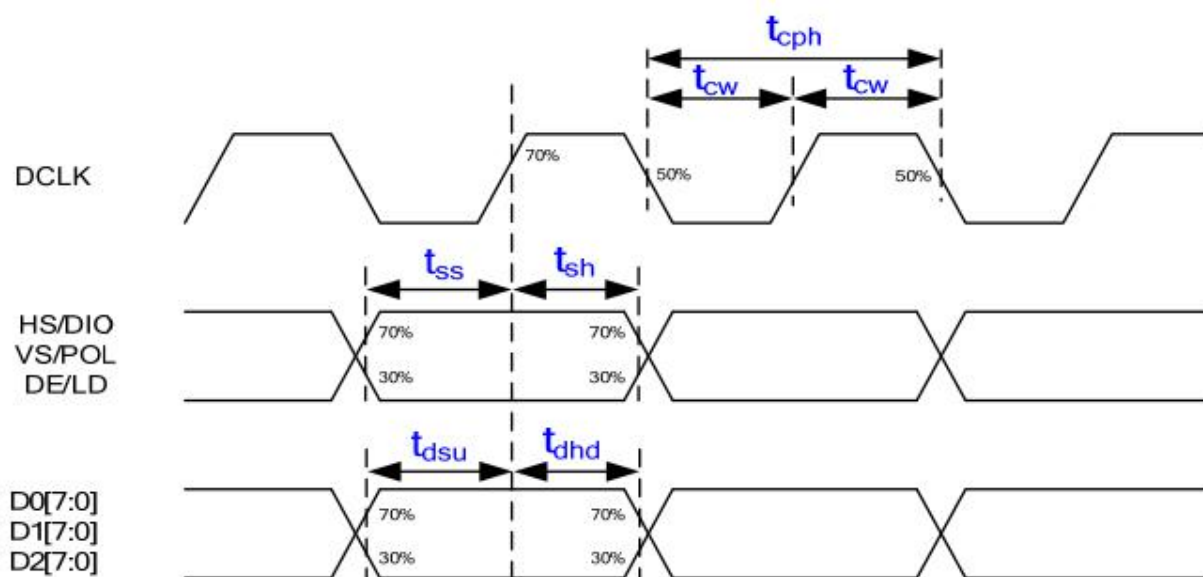

Parameter	Symbol	Spec.			Unit
		Min.	Typ.	Max.	
DCLK period	$T_{cph}$	16.67	-	-	ns
DCLK duty ratio	$T_{CW}$	40	50	60	%
Data setup time	$T_{dsu}$	5	-	-	ns
Data hold time	$T_{dhd}$	5	-	-	ns
VS/POL setup time	$T_{ss}$	5	-	-	ns
VS/POL hold time	$T_{sh}$	5	-	-	ns
HS/DIO setup time	$T_{ss}$	5	-	-	ns
HS/DIO hold time	$T_{sh}$	5	-	-	ns
DE/LD setup time	$T_{ss}$	5	-	-	ns
DE/LD hold time	$T_{sh}$	5	-	-	ns

### 6.5 Reset timing

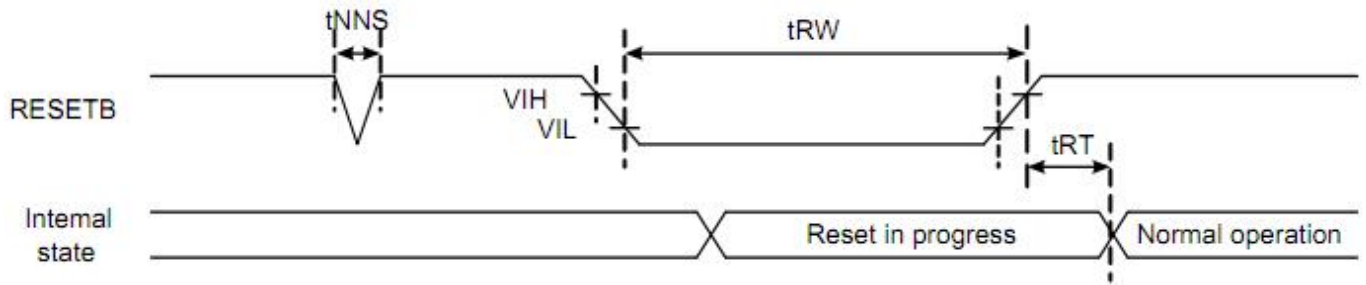

Signal	Parameter	Symbol	Spec.			Unit
			Min.	Typ.	Max.	
RESETB	Reset pulse width	tRW	10	-	-	μs
	Reset complete time	tRT	-	-	5	μs
	Negative spike noise width	tNNS	-	-	100	ns

### 6.6 LVDS interface

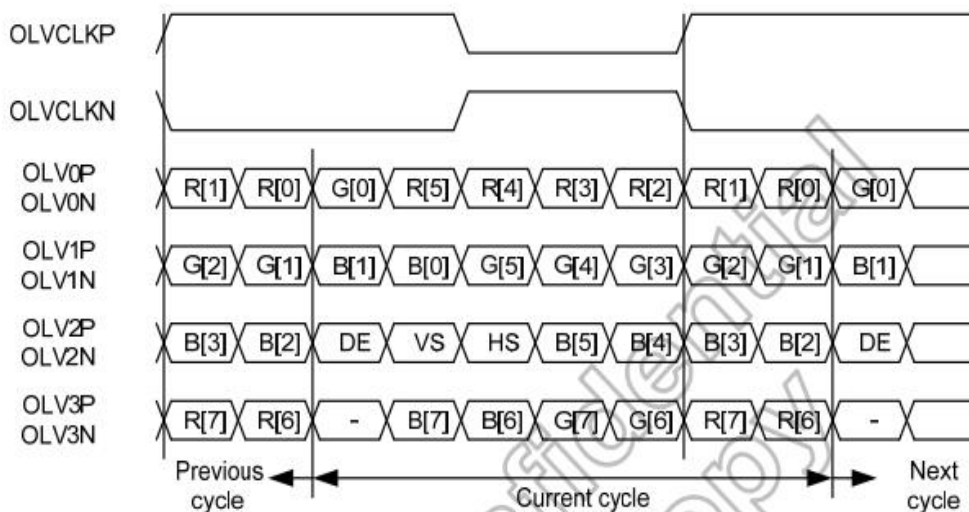

8bit mode

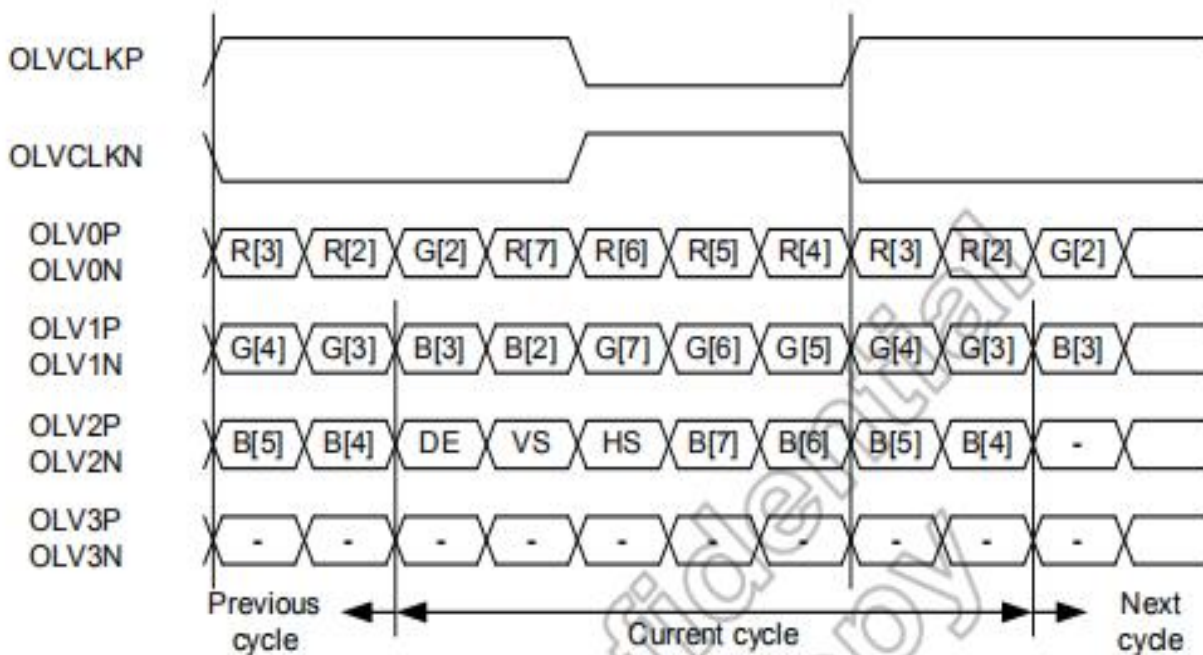

6bit mode

### 6.6 Block Diagram

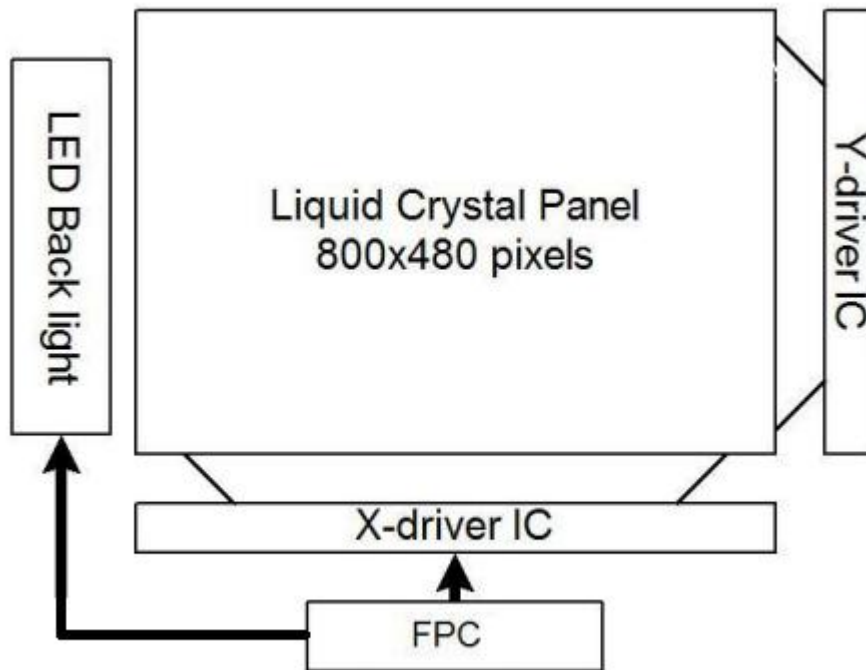

**Pixel Format**

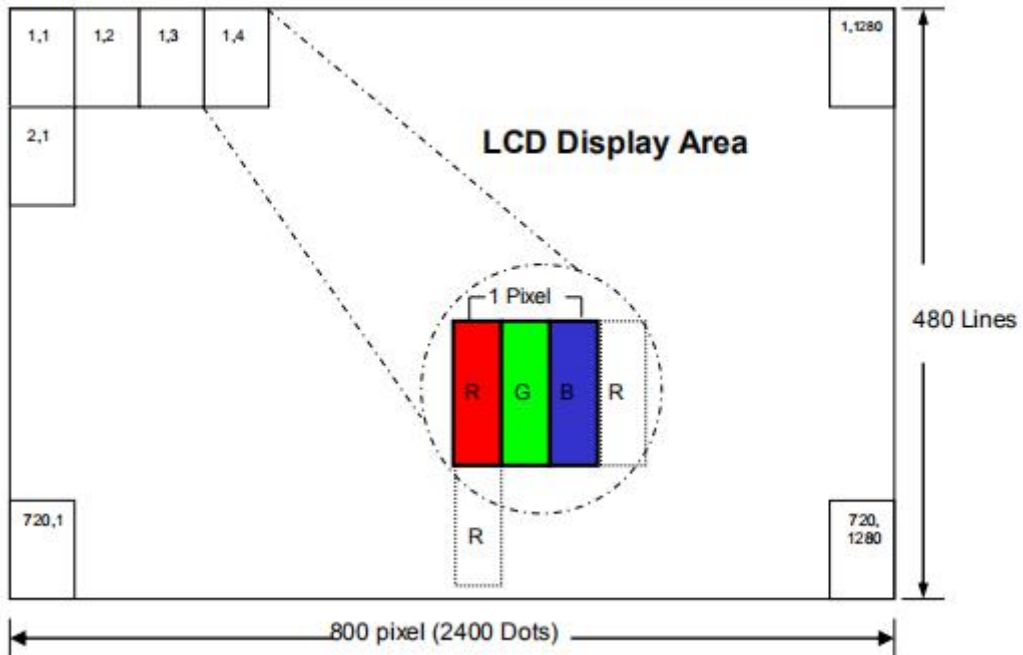



### Relationship Between Displayed Color and Input

	Display	MSB				LSB				MSB				LSB				Gray scale									
		R7	R6	R5	R4	R3	R2	R1	R0	G7	G6	G5	G4	G3	G2	G1	G0	B7	B6	B5	B4	B3	B2	B1	B0	Level	
Basic color	Black	L	L	L	L	L	L	L	L	L	L	L	L	L	L	L	L	L	L	L	L	L	L	L	L	-	
	Blue	L	L	L	L	L	L	L	L	L	L	L	L	L	L	L	L	H	H	H	H	H	H	H	H	-	
	Green	L	L	L	L	L	L	L	L	H	H	H	H	H	H	H	H	L	L	L	L	L	L	L	L	-	
	Light Blue	L	L	L	L	L	L	L	L	H	H	H	H	H	H	H	H	H	H	H	H	H	H	H	H	-	
	Red	H	H	H	H	H	H	H	H	L	L	L	L	L	L	L	L	L	L	L	L	L	L	L	L	-	
	Purple	H	H	H	H	H	H	H	H	L	L	L	L	L	L	L	L	H	H	H	H	H	H	H	H	-	
	Yellow	H	H	H	H	H	H	H	H	H	H	H	H	H	H	H	H	L	L	L	L	L	L	L	L	-	
	White	H	H	H	H	H	H	H	H	H	H	H	H	H	H	H	H	H	H	H	H	H	H	H	H	-	
Gray scale of Red	Black	L	L	L	L	L	L	L	L	L	L	L	L	L	L	L	L	L	L	L	L	L	L	L	L	L0	
	Dark ↑	L	L	L	L	L	L	L	H	L	L	L	L	L	L	L	L	L	L	L	L	L	L	L	L	L1	
		L	L	L	L	L	L	H	L	L	L	L	L	L	L	L	L	L	L	L	L	L	L	L	L	L2	
		:	:	:	:	:	:	:	:	:	:	:	:	:	:	:	:	:	:	:	:	:	:	:	:	L3...L251	
		H	H	H	H	H	H	L	L	L	L	L	L	L	L	L	L	L	L	L	L	L	L	L	L	L252	
	Light ↓	H	H	H	H	H	H	L	H	L	L	L	L	L	L	L	L	L	L	L	L	L	L	L	L	L253	
		H	H	H	H	H	H	L	H	L	L	L	L	L	L	L	L	L	L	L	L	L	L	L	L	L254	
	Red	H	H	H	H	H	H	H	H	L	L	L	L	L	L	L	L	L	L	L	L	L	L	L	L	Red L255	
Gray scale of Green	Black	L	L	L	L	L	L	L	L	L	L	L	L	L	L	L	L	L	L	L	L	L	L	L	L	L0	
	Dark ↑	L	L	L	L	L	L	L	L	L	L	L	L	L	L	H	L	L	L	L	L	L	L	L	L	L1	
		L	L	L	L	L	L	L	L	L	L	L	L	L	H	L	L	L	L	L	L	L	L	L	L	L2	
		:	:	:	:	:	:	:	:	:	:	:	:	:	:	:	:	:	:	:	:	:	:	:	:	L3...L251	
		L	L	L	L	L	L	L	L	H	H	H	H	H	L	L	L	L	L	L	L	L	L	L	L	L252	
	Light ↓	L	L	L	L	L	L	L	L	H	H	H	H	H	L	H	L	L	L	L	L	L	L	L	L253		
		L	L	L	L	L	L	L	L	H	H	H	H	H	L	L	L	L	L	L	L	L	L	L	L254		
	Green	L	L	L	L	L	L	L	L	H	H	H	H	H	H	H	L	L	L	L	L	L	L	L	Green L255		
Gray scale of Blue	Black	L	L	L	L	L	L	L	L	L	L	L	L	L	L	L	L	L	L	L	L	L	L	L	L	L0	
	Dark ↑	L	L	L	L	L	L	L	L	L	L	L	L	L	L	L	L	L	L	L	L	L	L	H	L	L1	
		L	L	L	L	L	L	L	L	L	L	L	L	L	L	L	L	L	L	L	L	L	H	L	L	L2	
		:	:	:	:	:	:	:	:	:	:	:	:	:	:	:	:	:	:	:	:	:	:	:	:	L3...L251	
		L	L	L	L	L	L	L	L	L	L	L	L	L	L	L	L	H	H	H	H	H	L	L	L	L252	
	Light ↓	L	L	L	L	L	L	L	L	L	L	L	L	L	L	L	L	H	H	H	H	H	L	H	L	L253	
		L	L	L	L	L	L	L	L	L	L	L	L	L	L	L	L	H	H	H	H	H	L	L	L	L254	
	Blue	L	L	L	L	L	L	L	L	L	L	L	L	L	L	L	L	H	H	H	H	H	H	H	H	Blue L255	
Gray scale of White & Black	Black	L	L	L	L	L	L	L	L	L	L	L	L	L	L	L	L	L	L	L	L	L	L	L	L	L0	
	Dark ↑	L	L	L	L	L	L	L	H	L	L	L	L	L	L	H	L	L	L	L	L	L	L	H	L1		
		L	L	L	L	L	L	H	L	L	L	L	L	L	H	L	L	L	L	L	L	H	L	L	L2		
		:	:	:	:	:	:	:	:	:	:	:	:	:	:	:	:	:	:	:	:	:	:	:	L3...L251		
		H	H	H	H	H	L	L	L	H	H	H	H	L	L	L	H	H	H	H	L	L	L	L	L252		
	Light ↓	H	H	H	H	H	L	H	H	H	H	H	L	H	H	H	H	H	L	H	H	H	H	H	L	H	L253
		H	H	H	H	H	L	H	H	H	H	H	L	H	H	H	H	H	L	H	H	H	H	H	L	H	L254
	White	H	H	H	H	H	H	H	H	H	H	H	H	H	H	H	H	H	H	H	H	H	H	H	White L255		

**6.7 Input timing table**

ITEM		SYMBOL	MIN	TYP	MAX	UNIT	
DCLK	Frequency	f <sub>CLK</sub>	25	30.4	45	MHz	
	Period	t <sub>CLK</sub>	22.2	32.9	40	ns	
DENA	Horizontal	Active Time	t <sub>HA</sub>	800	800	800	t <sub>CLK</sub>
		Blanking Time	t <sub>HB</sub>	20	160	--	t <sub>CLK</sub>
		Frequency	f <sub>H</sub>	26.4	31.7	45	kHz
		Period	t <sub>H</sub>	22.2	31.6	37.9	μs
	Vertical	Active Time	t <sub>VA</sub>	480	480	480	t <sub>H</sub>
		Blanking Time	t <sub>VB</sub>	3	48	--	t <sub>H</sub>
		Frequency	f <sub>V</sub>	55	60	75	Hz
		Period	t <sub>V</sub>	13.3	16.7	18.2	ms

### 7. Optical Characteristics

Item	Symbol	Condition	Min.	Typ.	Max.	Unit	Note
Luminance	Bp	$\theta=0^\circ$	-	1000*	-	Cd/m <sup>2</sup>	1
Uniformity	$\Delta$ Bp	$\Phi=0^\circ$	75	80	-	%	1,2
Viewing Angle	3:00	Cr $\geq$ 10	75	80	-	Deg	3
	6:00		75	80	-		
	9:00		75	80	-		
	12:00		75	80	-		
Contrast Ratio	Cr	$\theta=0^\circ$	500	800	-	-	4
Response Time	T <sub>r</sub> +T <sub>f</sub>	$\Phi=0^\circ$	-	25	35	ms	5
Color of CIE Coordinate	W	x	Typ -0.05	0.306	Typ +0.05	-	1,6
		y		0.331		-	
	R	x		0.648		-	
		y		0.317		-	
	G	x		0.286		-	
		y		0.606		-	
	B	x		0.138		-	
		y		0.098		-	
NTSC Ratio	S	-	71.7	-	%		

\* 1300 cd/m<sup>2</sup> @ 500 mA

Note: The parameter is slightly changed by temperature, driving voltage and materiel

Note 1: The data are measured after LEDs are turned on for 5 minutes. LCM displays full white. The brightness is the average value of 9 measured spots. Measurement equipment BM-7

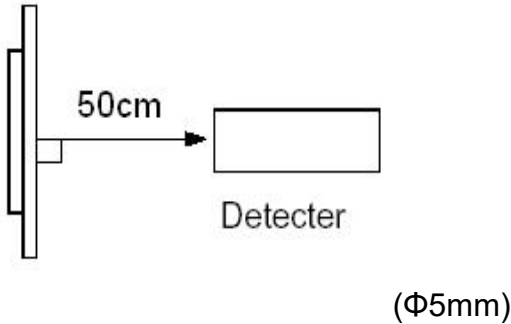

Measuring condition:

- Measuring surroundings: Dark room.
- Measuring temperature:  $T_a=25\text{ }^\circ\text{C}$ .
- Adjust operating voltage to get optimum contrast at the center of the display.

Measured value at the center point of LCD panel after more than 5 minutes while backlight turning on.

Note 2: The luminance uniformity is calculated by using following formula.

$$\Delta B_p = B_p (\text{Min.}) / B_p (\text{Max.}) \times 100 (\%)$$

$B_p (\text{Max.})$  = Maximum brightness in 9 measured spots

$B_p (\text{Min.})$  = Minimum brightness in 9 measured spots.

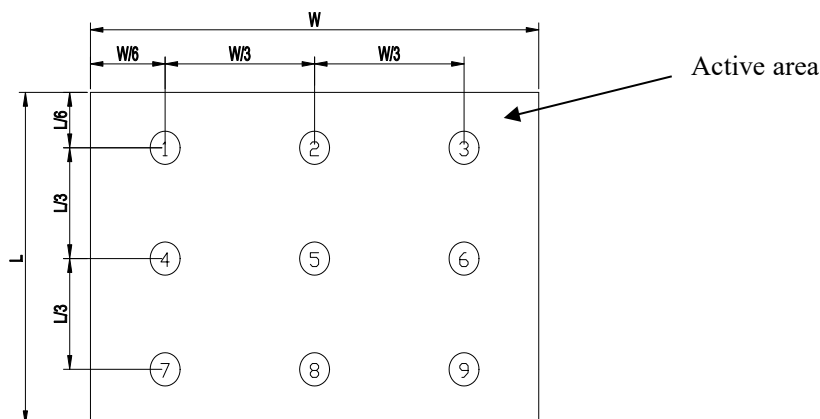

Note 3: The definition of viewing angle:  
Refer to the graph below marked by  $\theta$  and  $\Phi$

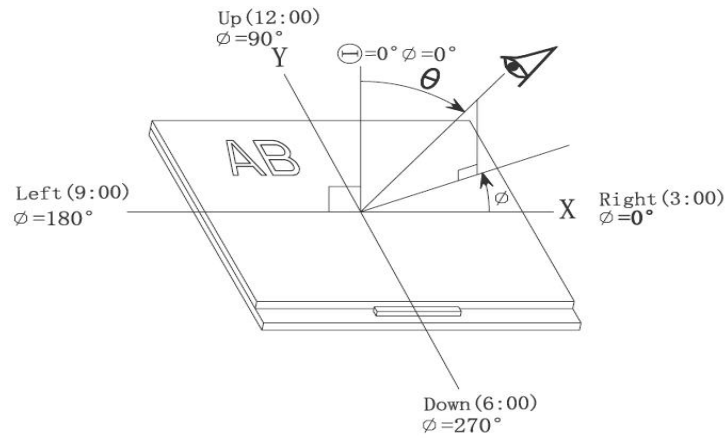

Note 4: Definition of contrast ratio.( Test LCD using DMS501)

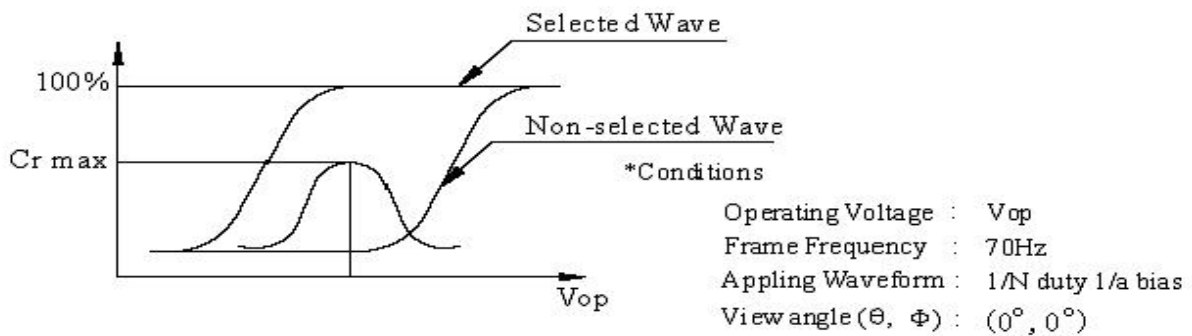

$$\text{Contrast ratio}(Cr) = \frac{\text{Brightness of selected dots}}{\text{Brightness of non-selected dots}}$$

Note 5: Definition of Response time. (Test LCD using DMS501):

The output signals of photo detector are measured when the input signals are changed from "black" to "white" (falling time) and from "white" to "black" (rising time), respectively. The response time is defined as the time interval between the 10% and 90% of amplitudes. Refer to figure as below.

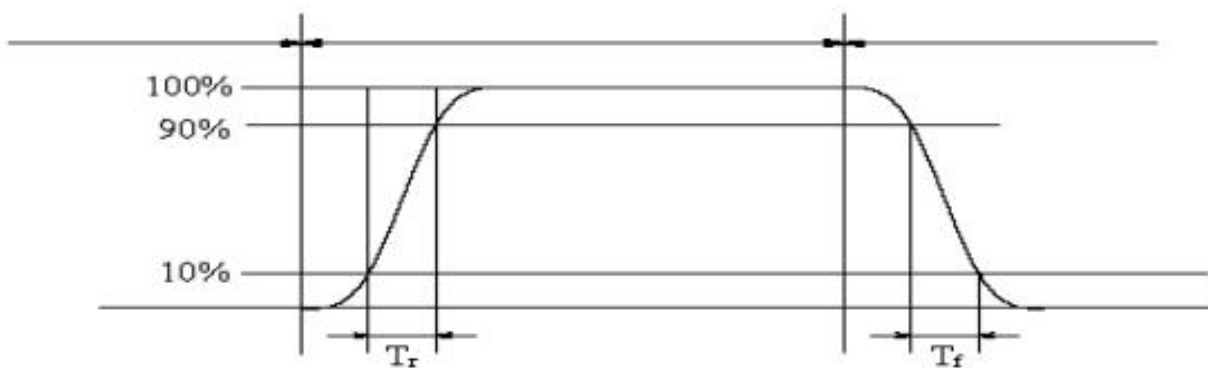

The definition of response time

Note 6: Definition of Color of CIE Coordinate and NTSC Ratio, and comparison of color gamut between sRGB vs. Distec DD-0700-MC01 (yellow) vs. Mitsubishi AA070MC01 (blue)

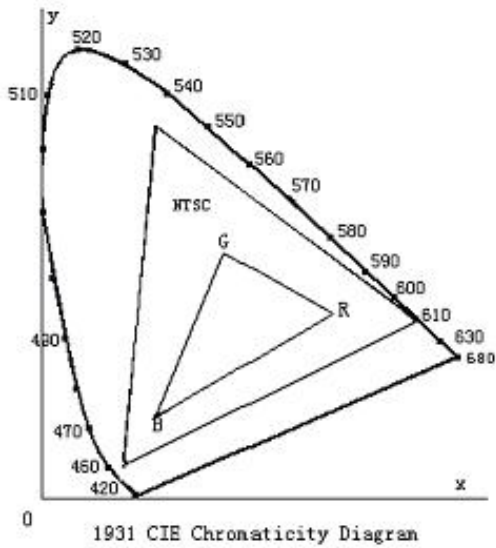

Color gamut:

$$S = \frac{\text{area of RGB triangle}}{\text{area of NTSC triangle}} \times 100\%$$

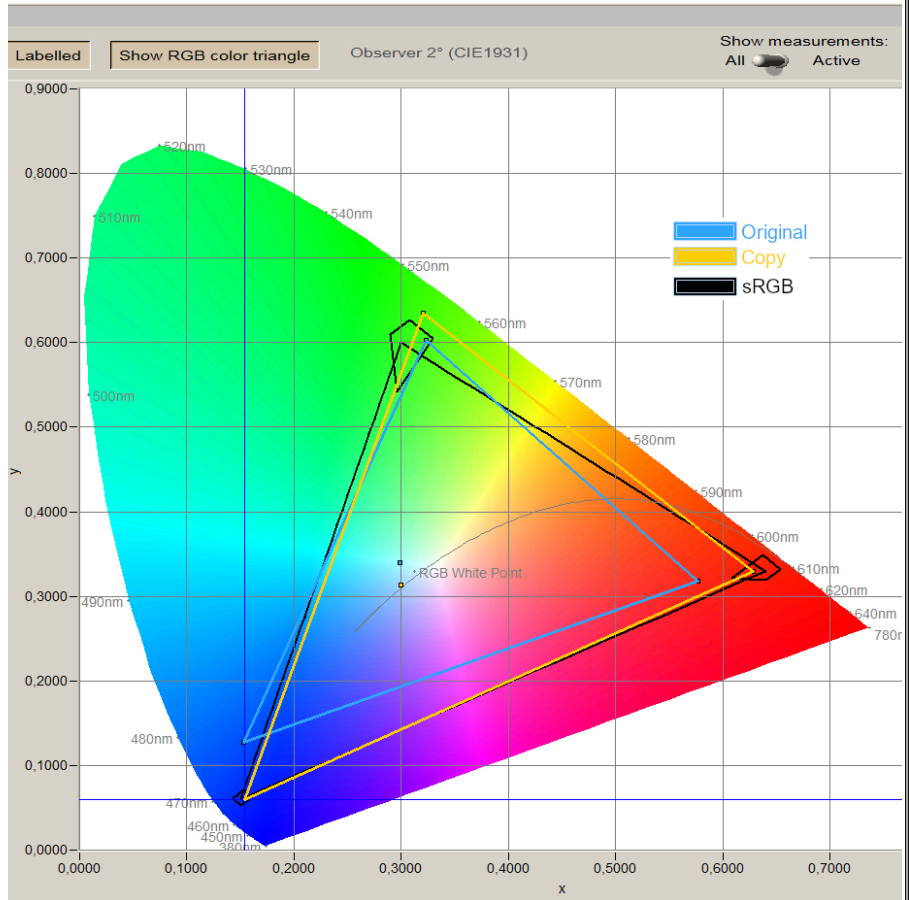

Note 7: Definition of cross talk.

$$\text{Cross talk ratio(\%)} = \frac{|\text{pattern A Brightness} - \text{pattern B Brightness}|}{\text{pattern A Brightness}} \times 100$$

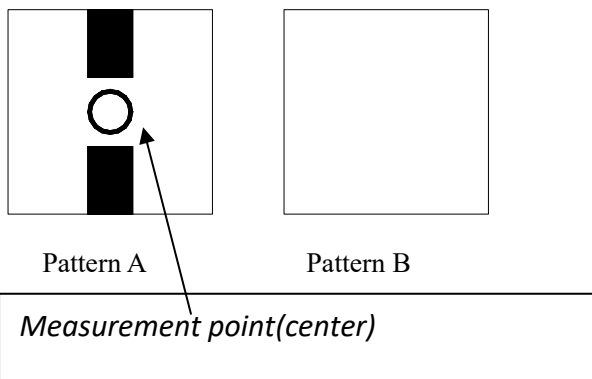

Electric volume value =  $3F \pm 3Hex$

### 8. Reliability Test Items and Criteria

Test Item	Test condition	Remark
High Temperature Storage	Ta = 80°C 240hrs	Note1,Note3, 4
Low Temperature Storage	Ta = 80°C 240hrs	Note1,Note3, 4
High Temperature Operation	Ta =80°C 240hrs	Note2,Note3, 4
Low Temperature Operation	Ta = 80°C 240hrs	Note1,Note3, 4
Operation at High Temperature/Humidity	+60°C, 90%RH 240hrs	Note3, 4
Thermal Shock	-30°C/30 min ~ +80°C/30 min for a total 50 cycles, Start with cold temperature and end with high temperature.	Note3, 4
Vibration Test	Frequency range:10~55Hz Stroke:1.5mm Sweep:10Hz~55Hz~10Hz 2 hours for each direction of X. Y. Z. (6 hours for total)	
Mechanical Shock (NON-OPERATION)	Shock level: 1470 m/s <sup>2</sup> (150G) Waveform: half sinusoidal wave, 2 ms Number of shocks: one shock input in each direction of three mutually perpendicular axes for a total of six shock inputs	
Vibration Test (NON-OPERATION)	Vibration level: 9.8 m/s <sup>2</sup> (1.0G) Waveform: sinusoidal Frequency range: 5 to 500 Hz Frequency sweep rate: 0.5 octave /min Duration: one sweep from 5 to 500 Hz in each of three mutually perpendicular axis(each x,y,z axis: 1 hour, total 3 hours)	
Package Drop Test	Height:60cm 1 corner, 3 edges, 6 surfaces	
CONTACT DISCHARGE (OPERATION)	150pF, 330Ω , 8kV, 10 times at 1 sec interval	
SIGNAL PIN DISCHARGE (NON-OPERATION)	200pF, 0Ω , 200V, 10 times at 1 sec interval	

Note 1: Ta is the ambient temperature of samples.

Note 2:  $T_s$  is the temperature of panel's surface.

Note 3: In the standard condition, there shall be no practical problem that may affect the display function. After the reliability test, the product only guarantees operation, but don't guarantee all of the cosmetic specification.

Note 4: Before cosmetic and function test, the product must have enough recovery time, at least 2 hours at room temperature

## **9. Precautions for Use of LCD Modules**

### **9.1 Handling Precautions**

9.1.1 *The display panel is made of glass. Do not subject it to a mechanical shock by dropping it from a high place, etc.*

9.1.2 *If the display panel is damaged and the liquid crystal substance inside it leaks out, be sure not to get any in your mouth, if the substance comes into contact with your skin or clothes, promptly wash it off using soap and water.*

9.1.3 *Do not apply excessive force to the display surface or the adjoining areas since this may cause the color tone to vary.*

9.1.4 *The polarizer covering the display surface of the LCD module is soft and easily scratched. Handle this polarizer carefully.*

9.1.5 *If the display surface is contaminated, breathe on the surface and gently wipe it with a soft dry cloth. If still not completely clear, moisten cloth with one of the following solvents:*

— Isopropyl alcohol      — Ethyl alcohol

*Solvents other than those mentioned above may damage the polarizer. Especially, do not use the following:*

— Water                      — Ketone                      — Aromatic solvents

9.1.6 *Do not attempt to disassemble the LCD Module.*

9.1.7 *If the logic circuit power is off, do not apply the input signals.*

9.1.8 *To prevent destruction of the elements by static electricity, be careful to maintain an optimum work environment.*

a. *Be sure to ground the body when handling the LCD Modules.*

b. *Tools required for assembly, such as soldering irons, must be properly ground.*



- c. *To reduce the amount of static electricity generated, do not conduct assembly and other work under dry conditions.*
- d. *The LCD Module is coated with a film to protect the display surface. Be care when peeling off this protective film since static electricity may be generated.*

## **9.2 Storage precautions**

9.2.1 *When storing the LCD modules, avoid exposure to direct sunlight or to the light of fluorescent lamps.*

9.2.2 *The LCD modules should be stored under the storage temperature range. If the LCD modules will be stored for a long time, the recommend condition is:*

*Temperature :           0 °C ~ 40 °C*

*Relatively humidity: ≤80%*

9.2.3 *The LCD modules should be stored in the room without acid, alkali and harmful gas.*

**9.3 *The LCD modules should be no falling and violent shocking during transportation, and also should avoid excessive press, water, damp and sunshine.***

**END**

Our company network supports you worldwide with offices in Germany, Austria, Switzerland, the UK and the USA. For more information please contact:

## Headquarters

### Germany



### FORTEC Elektronik AG

Augsburger Str. 2b  
82110 Germering

Phone: +49 89 894450-0  
E-Mail: [info@forteca.de](mailto:info@forteca.de)  
Internet: [www.forteca.de](http://www.forteca.de)

## Fortec Group Members

### Austria



### Distec GmbH Office Vienna

Nuschinggasse 12  
1230 Wien

Phone: +43 1 8673492-0  
E-Mail: [info@distec.de](mailto:info@distec.de)  
Internet: [www.distec.de](http://www.distec.de)

### Germany



### Distec GmbH

Augsburger Str. 2b  
82110 Germering

Phone: +49 89 894363-0  
E-Mail: [info@distec.de](mailto:info@distec.de)  
Internet: [www.distec.de](http://www.distec.de)

### Switzerland



### ALTRAC AG

Bahnhofstraße 3  
5436 Würenlos

Phone: +41 44 7446111  
E-Mail: [info@altrac.ch](mailto:info@altrac.ch)  
Internet: [www.altrac.ch](http://www.altrac.ch)

### United Kingdom



### Display Technology Ltd.

Osprey House, 1 Osprey Court  
Hichingbrooke Business Park  
Huntingdon, Cambridgeshire, PE29 6FN

Phone: +44 1480 411600  
E-Mail: [info@displaytechnology.co.uk](mailto:info@displaytechnology.co.uk)  
Internet: [www.displaytechnology.co.uk](http://www.displaytechnology.co.uk)

### USA



### Apollo Display Technologies, Corp.

87 Raynor Avenue,  
Unit 1 Ronkonkoma,  
NY 11779

Phone: +1 631 5804360  
E-Mail: [info@apolloDisplays.com](mailto:info@apolloDisplays.com)  
Internet: [www.apolloDisplays.com](http://www.apolloDisplays.com)