



OUR GLOBAL
COMPETENCE
CENTRES

 APOLLO DISPLAY
TECHNOLOGIES



 DISTEC



 DISPLAY
TECHNOLOGY



Datasheet

Distec

DD0840XE11-C

DD-01-006

PRODUCT SPECIFICATIONS(Preliminary)

For Customer: _____

: APPROVAL FOR SPECIFICATION

Customer Model No. _____

: APPROVAL FOR SAMPLE

Module No.: **DD-0840-XE11-C**

Date : 2021.02.04

Table of Contents

No.	Item	Page
1	Table of Contents	P3
2	Revision Record	P4
3	General Specifications	P5
4	Outline Drawing	P6
5	Absolute Maximum Ratings	P7
6	Electrical Specifications	P9
7	Optical Characteristics	P17
8	Reliability Test Items and Criteria	P21
9	Precautions for Use of LCD Modules	P22

For Customer's Acceptance:

Approved By	Comment

PREPARED	CHECKED	VERIFIED BY QA DEPT	VERIFIED BY R&D DEPT
LC			

3. General Specifications

DD-0840-XE11-C is an 8.4" high brightness color TFT-LCD (Thin Film Transistor Liquid Crystal Display) module composed of LCD panel, driver ICs, control circuit, LED driver and backlight unit. The 8.4" display area contains 1024 x (RGB) x 768 pixels and can display up to 16.7M colors. This product is RoHS compliant. UL No. 62368-1.

Item	Contents	Unit	Note
LCD Type	TFT	-	
Display color	16.7M		1
Viewing Direction	ALL	O'Clock	
Operating temperature	-30~+80	°C	
Storage temperature	-30~+80	°C	
Module size	199.50X149.00X9.7	mm	2
Active Area(W×H)	170.496X127.872	mm	
Number of Dots	1024 X 768	dots	
Power Supply Voltage	3.3	V	
TFT Controller	HX8290-A-LT*2+HX8695-E-LT		
Weight	---	g	
Interface	LVDS	-	
Surface treatment	Anti-Glare and hard-coating 3H		

Note 1: Color tune is slightly changed by temperature and driving voltage.

Note 2: Without FPC and Solder.

4.Outline.Drawing

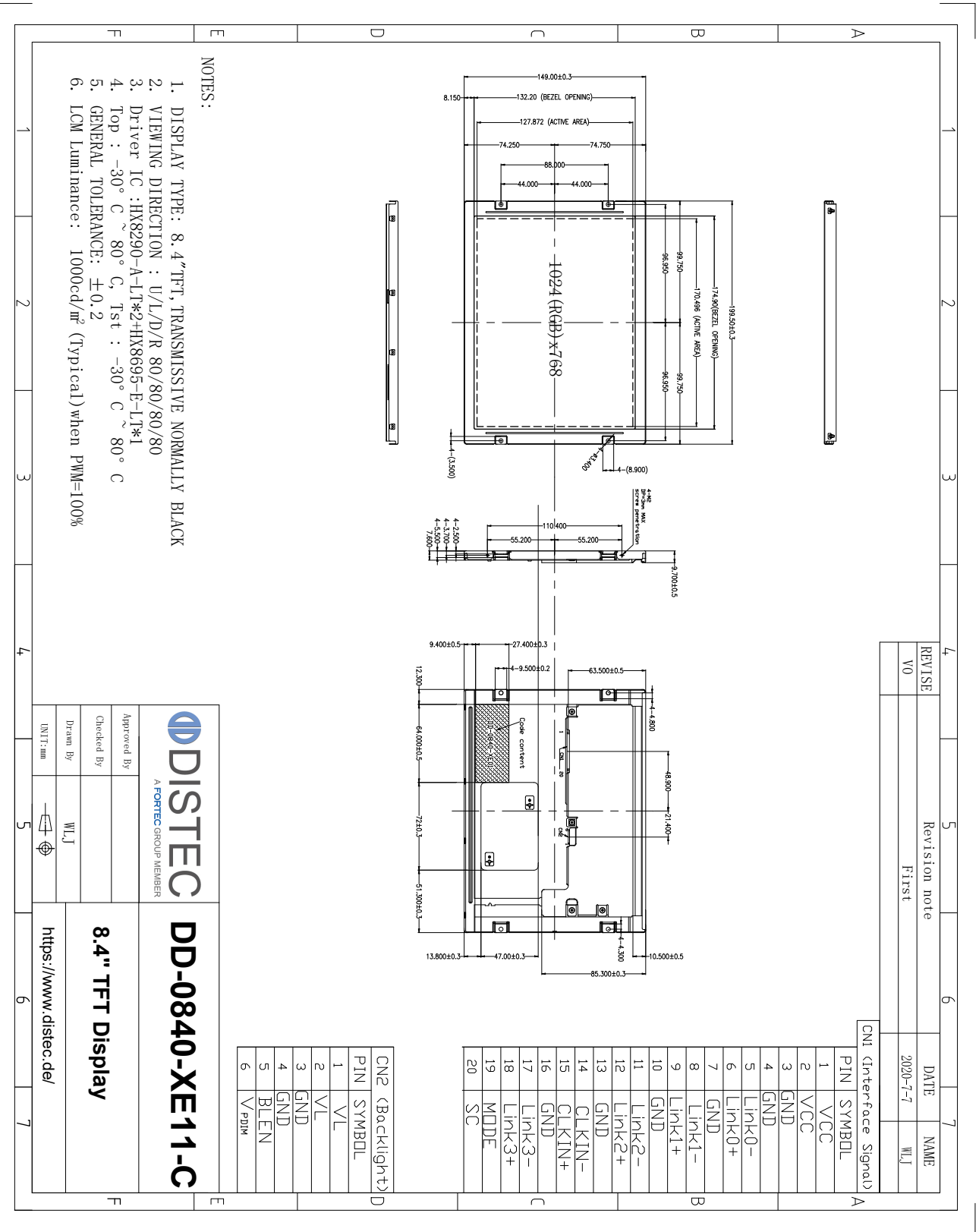

- NOTES:
1. DISPLAY TYPE: 8.4" TFT, TRANSMISSIVE NORMALLY BLACK
 2. VIEWING DIRECTION : U/L/D/R 80/80/80/80
 3. Driver IC :HX8290-A-LT*2+HX8695-E-LT*1
 4. Top : -30° C ~ 80° C, Tst : -30° C ~ 80° C
 5. GENERAL TOLERANCE: ±0.2
 6. LCM Luminance: 1000cd/m² (Typical) when PWM=100%

REVISE	Revision note	DATE	NAME
V0	First	2020-7-7	WJ

DISTEC
A FORTEC GROUP MEMBER

DD-0840-XE11-C

8.4" TFT Display

Approved By: _____
Checked By: _____
Drawn By: WJ
UNIT: mm

<https://www.distec.de/>

5. Absolute Maximum Ratings ($T_a=25\text{ }^\circ\text{C}$)

5.1 Electrical Absolute Maximum Ratings. ($V_{SS}=0\text{V}$, $T_a=25\text{ }^\circ\text{C}$)

Item	Symbol	Min.	Max.	Unit	Note
Power Supply Voltage	VCC	-0.3	4.0	V	1, 2
	VL	-0.3	14.0	V	1, 2
	VPDIM	-0.3	14.0	V	1, 2
	BLEN	-0.3	14.0	V	1, 2

Notes:

1. If the module is used above these absolute maximum ratings, it may become permanently damaged. Using the module out of the indicated electrical range may cause malfunction and poor reliability.
2. $V_{CC} > V_{SS}$ must be maintained.
3. Please make sure users are grounded when handing LCD Module.

5.2 Environmental Absolute Maximum Ratings.

Item	Storage		Operating		Note
	MIN.	MAX.	MIN.	MAX.	
Ambient Temperature	-30 $^\circ\text{C}$	80 $^\circ\text{C}$	-30 $^\circ\text{C}$	80 $^\circ\text{C}$	1,2
Humidity	-	-	-	-	3

1. The response time will become lower when operated at low temperature.
2. Background color changes slightly depending on ambient temperature.
The phenomenon is reversible.
3. $T_a \leq 40\text{ }^\circ\text{C}$: 85%RH MAX.
 $T_a > 40\text{ }^\circ\text{C}$: Absolute humidity must be lower than the humidity of 85%RH at 40 $^\circ\text{C}$.

6. Electrical Specifications

6.1 Electrical characteristics for LCD($V_{SS}=0V$, $T_a=25^\circ C$)

Parameter	Symbol	Condition	Min	Typ	Max	Unit	Note
Power supply	VCC	$T_a=25^\circ C$	3.0	3.3	3.6	V	
Backlight Power supply	VL	$T_a=25^\circ C$	9	12.0	13.2	V	
Input voltage	'H'	V_{IH}	$0.7V_{CC}$	-	VCC	V	
	'L'	V_{IL}	-0.3	-	$0.3V_{CC}$	V	
Current of power supply	ICC	$T_a=25^\circ C$	-	180	-	mA	

6.2 LED backlight specification($V_{SS}=0V$, $T_a=25^\circ C$)

Item	Symbol	Min	Typ	Max	Unit	Note	
Supply voltage	VL	9	12.0	13.2	V		
Supply Current	IL	-	350	-	mA	(VL=12V) PWM=100%	
Power Consumption	PL	-	4.2	-	W	(VL=12V) PWM=100%	
PWM Control Frequency	F_{PDIM}	100	-	30K	Hz		
Backlight ON-OFF	High	BLEN	1.6	-	VL	V	
	Low		0	-	0.8	V	
PWM Control Level	High	V_{PDIM}	1.6	-	VL	V	
	Low		0	-	0.8	V	
Uniformity	ΔBp	75	80	-	%		
Life Time	time	50K	-	-	hours	1	

Note 1: Brightness to be decreased to 50% of the initial value at ambient temperature $T_a=25^\circ C$

6.3 Interface signals

6.3.1 CN 1(Interface Signal)

Used connector: 20186-020E-11F (I-PEX) or FI-SEB20P-HFE (JAE)

Corresponding connector: 20197- 20U-F (I-PEX) or FI-S20S[for discrete Wire],
FI-SE20ME[for FPC] (JAE)

Pin No.	Symbol	I/O	Function
1-2	VCC	P	Power supply
3-4	GND	P	Ground.
5	LINK0-	I	LVDS lane0 input
6	LINK0+	I	
7	GND	P	Ground.
8	LINK1-	I	LVDS lane1 input
9	LINK1+	I	
10	GND	P	Ground.
11	LINK2-	I	LVDS lane2 input
12	LINK2+	I	
13	GND	P	Ground.
14	CLKIN-	I	LVDS CLK input
15	CLKIN+	I	
16	GND	P	Ground.
17	LINK3-	I	LVDS lane3 input
18	LINK3+	I	
19	NC	-	No connection
20	SC	I	Scan direction control (Low=Normal, High=Reverse)

6.3.1 CN 2(Backlight)**Backlight-side connector: FI-S6P-HFE (JAE)****Corresponding connector: FI-S6S (JAE)**

Pin No.	Symbol	I/O	Function
1-2	VL	P	Power supply For BL.
3-4	GND	P	Ground.
5	BLEN	I	LED driver enable input
6	VPDIM	I	PWM dimming control input.

6.4 AC Characteristics

6.4.1 For the digital circuit: LVDS mode

Parameter	Symbol	Condition	Spec.			Unit
			Min.	Typ.	Max.	
Differential input high Threshold voltage	V_{th}	$V_{cm}=1.2V$	-	-	+0.1	V
Differential input low threshold voltage	V_{tl}	-	-0.1	-	-	V
Differential input common Mode voltage	V_{CM}	-	1	1.2	$1.7- V_{id} /2$	V
LVDS input voltage	V_{INLV}	-	0.7	-	1.7	V
Differential input voltage	$ V_{id} $	-	0.1	-	0.6	V
Differential input leakage Current	I_{lvleak}	-	-10	-	+10	μA

Single-ended:
 LVCLKP(R),
 LVCLKN(R),
 LVD [3:0]P(R),
 LVD [3:0]N(R)

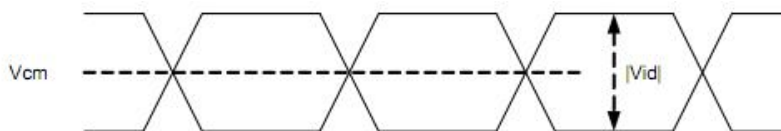

Differential:
 LVCLKP(R)-LVCLKN(R),
 LVD [3:0]P(R)-
 LVD [3:0]N(R)

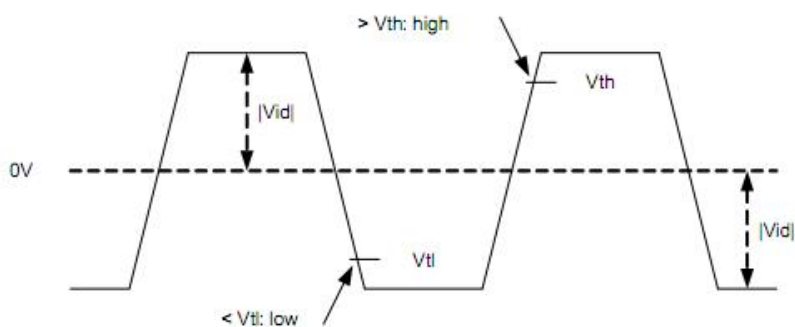

6.4.2 For the analog circuit: Normal mode

Parameter	Symbol	Conditions	Spec.			Unit
			Min.	Typ.	Max.	
Analog positive supply voltage	VSP	VSP is generated by PFM, VSPS [4:0]=14h, with proper settings and components.	6.7	7	7.3	V
Analog negative supply voltage	VSN	VSN is generated by PFM, VSNS [4:0]=14h, with proper settings and components.	-7.3	-7	-6.7	V
Source driver positive supply voltage	VSDP	VSP ≥ 7V, VSDPS[4:0]=14h, loading current=0	6.65	6.8	6.95	V
Source driver negative supply voltage	VSDN	VSN = -7V, VSDNS[4:0]=14h, loading current=0	-6.95	-6.8	-6.65	V
Output for positive gamma reference high voltage	VGMPHO	VSDP ≥ 6.8V, VGMPHS[4:0]=0x1Ah	6.48	6.6	6.72	V
Output for positive gamma reference voltage	VGMPMO	VSDP ≥ 6.8V, VGMPHS[4:0]=0x1Ah, VGMPLS[3:0]=0x00h	3.3	3.4	3.5	V

Output for positive gamma reference low voltage	VGMPLO	VGMPLS[3:0]=0x00h	0.12	0.2	0.28	V
Output for negative gamma reference high voltage	VGMNHO	VSDN ≤ -6.8V, VGMNHS[4:0]=0x1Ah	-6.72	-6.6	-6.48	V
Output for negative gamma reference voltage	VGMNMO	VSDN ≤ -6.8V, VGMNHS[4:0]=0x1Ah, VGMNLS[4:0]=0x00h	-3.5	-3.4	-3.3	V
Output for negative gamma reference low voltage	VGMNLO	VGMNLS[4:0]=0x00h	-0.28	-0.2	-0.12	V
VCOM voltage	VCOM	VCOMS[7:0]=0x80h	-1.53	-1.48	-1.43	V
Source output voltage, positive polarity	V _{SDOP}	-	0.2	-	VSDP-0.2	V
Source output voltage, negative polarity	V _{SDON}	-	VSDN+0.2	-	-0.2	V
Positive power supply	VGH	VGH is generated by charge pump, VGHS[3:0]=0x05h, loading current=0	14.6	15.6	16.6	V
Negative power supply	VGL	VGL is generated by charge pump, VGLS[2:0]=0x02h, loading current=0	-11	-10	-9	V

Parameter	Symbol	Conditions	Spec.			Unit
			Min.	Typ.	Max.	
Source output voltage deviation	V_{OD}	$V_{SDOP}=0.5V$ to $V_{SDP}-0.5V$, $V_{SDON}=V_{SDN}+0.5V$ to $-0.5V$	-	-	10	mV
		$V_{SDOP}=0.2V$ to $0.5V$ or $V_{SDOP}=V_{SDP}-0.5V$ to $V_{SDP}-0.2V$, $V_{SDON}=V_{SDN}+0.2V$ to $V_{SDN}+0.5V$ or $V_{SDON}=-0.5V$ to $-0.2V$	-	-	15	mV
Standby current (VCC1 + VCC2)	I_{STBVCC}	"STBYB=0" and all inputs are default.	-	-	100	μA
Standby current (VSN or VSP)	I_{STB}	"STBYB=0", VSP or VSN external input	-	-	100	μA

6.4.3 LVDS mode AC electrical characteristics

Parameter	Symbol	Spec.			Unit
		Min.	Typ.	Max.	
Clock frequency	$F_{LV CYC}$	20	-	85	MHz
Clock period	$T_{LV CYC}$	11.76	-	-	ns
1 data bit time	UI	-	1/7	-	$T_{LV CYC}$
Clock high time	$T_{LV CH}$	2.8	4	4.2	UI
Clock low time	$T_{LV CL}$	2.8	3	4.2	UI
Position 1	T_{POS1}	-0.2	0	0.2	UI
Position 0	T_{POS0}	0.8	1	1.2	UI
Position 6	T_{POS6}	1.8	2	2.2	UI
Position 5	T_{POS5}	2.8	3	3.2	UI
Position 4	T_{POS4}	3.8	4	4.2	UI
Position 3	T_{POS3}	4.8	5	5.2	UI
Position 2	T_{POS2}	5.8	6	6.2	UI
Input eye width	T_{EYEW}	0.6	-	-	UI
Input eye border	T_{EX}	-	-	0.2	UI
LVDS wake up time	T_{ENLVDS}	-	-	150	us

LVDS with SSC

Parameter	Symbol	Condition	Spec.			Unit
			Min.	Typ.	Max	
Modulation Frequency	SSC _{MF}	LVDS clock frequency center at 80MHz	-	-	200	KHz
		LVDS clock frequency center at 60MHz	-	-	150	KHz
		LVDS clock frequency center at 40MHz	-	-	100	KHz
		LVDS clock frequency center at 20MHz	-	-	50	KHz
Modulation Rate	SSC _{MR}	LVDS clock frequency + SSCMR in the range of 20MHz~85MHz	-	-	±5	%

6.4.4 TTL mode AC electrical characteristics

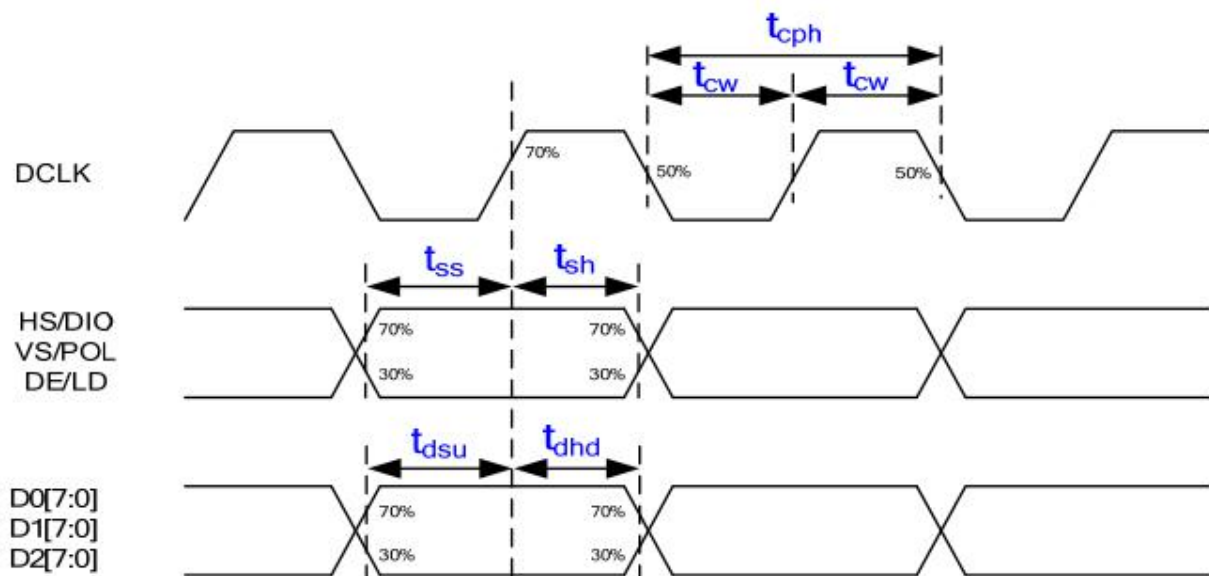

Parameter	Symbol	Spec.			Unit
		Min.	Typ.	Max.	
DCLK period	T_{cph}	16.67	-	-	ns
DCLK duty ratio	T_{cw}	40	50	60	%
Data setup time	T_{dsu}	5	-	-	ns
Data hold time	T_{dhd}	5	-	-	ns
VS/POL setup time	T_{ss}	5	-	-	ns
VS/POL hold time	T_{sh}	5	-	-	ns
HS/DIO setup time	T_{ss}	5	-	-	ns
HS/DIO hold time	T_{sh}	5	-	-	ns
DE/LD setup time	T_{ss}	5	-	-	ns
DE/LD hold time	T_{sh}	5	-	-	ns

6.5 Reset timing

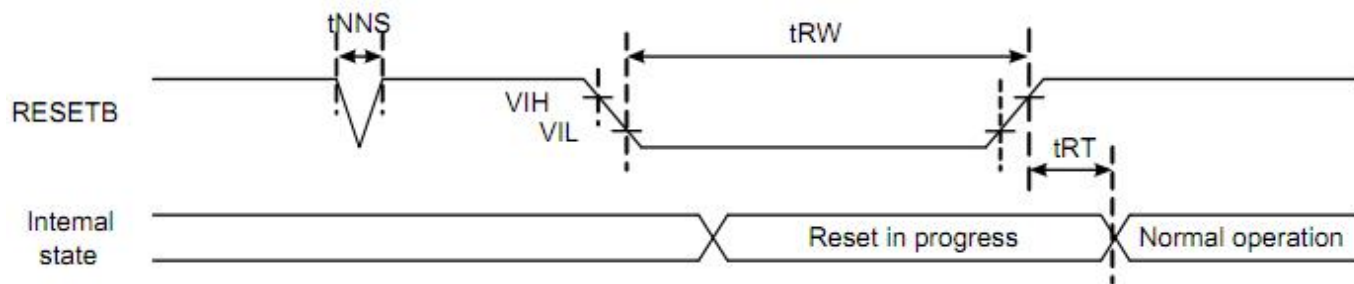

Signal	Parameter	Symbol	Spec.			Unit
			Min.	Typ.	Max.	
RESETB	Reset pulse width	tRW	10	-	-	μs
	Reset complete time	tRT	-	-	5	μs
	Negative spike noise width	tNNS	-	-	100	ns

6.6 LVDS interface data format

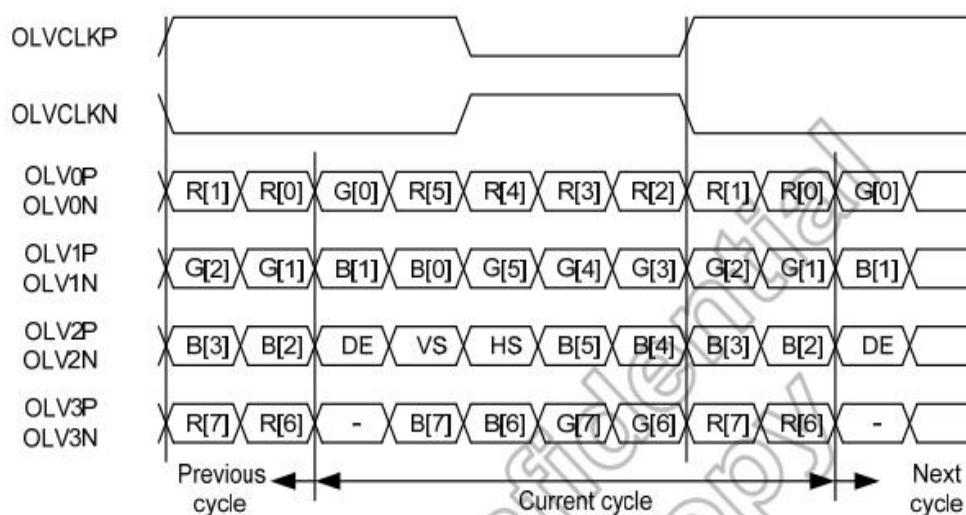

8bit mode

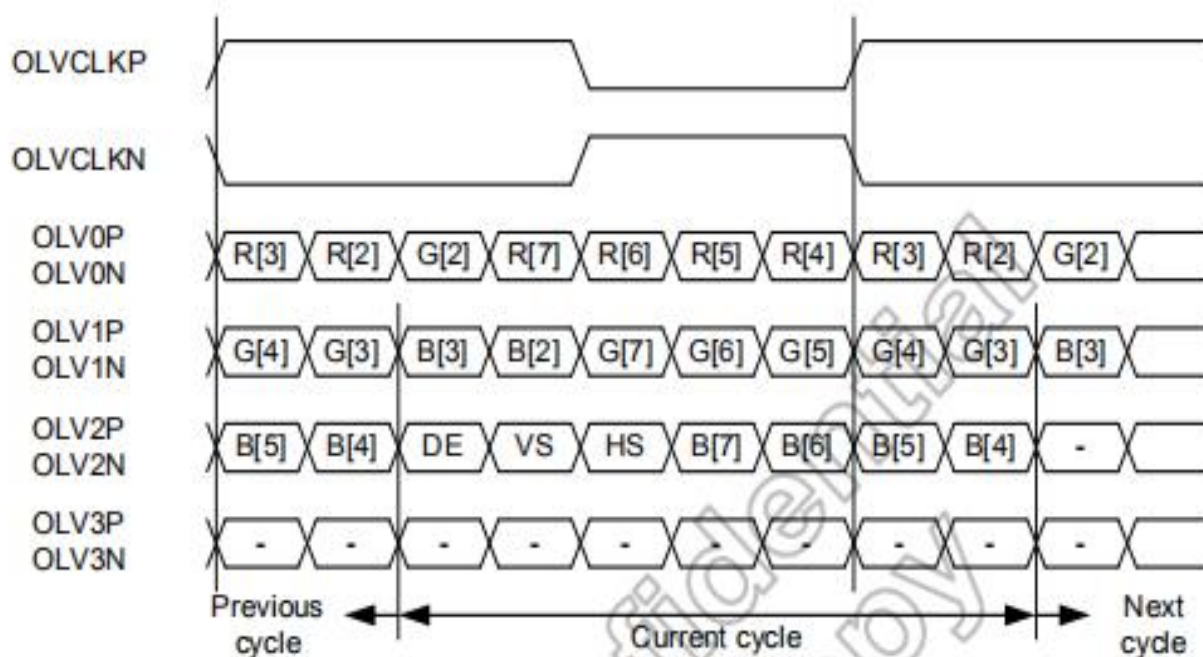

6bit mode

6.7 Input timing table

Parameter	Symbol	1024xRGBx768			Unit
		Min.	Typ.	Max.	
		DCLK frequency	F_{DCLK}	49.0	
Horizontal valid data	t_{hd}	1024			DCLK
1 Horizontal line	t_h	1053	1066	1331	DCLK
Vertical valid data	t_{vd}	768			H
1 Vertical field	t_v	775	781	998	H
Frame rate	FR	-	60	-	Hz

7. Optical Characteristics

Item	Symbol	Condition	Min.	Typ.	Max.	Unit	Note	
Brightness	Bp	$\theta=0^\circ$ $\Phi=0^\circ$	-	1000	-	Cd/m ²	1	
Uniformity	Δ Bp		75	80	-	%	1,2	
Viewing Angle	3:00	Cr \geq 10	75	80	-	Deg	3	
	6:00		75	80	-			
	9:00		75	80	-			
	12:00		75	80	-			
Contrast Ratio	Cr	Ta=25°C $\Phi=0^\circ$	800	1000	-	-	4	
Response Time	T _r +T _f		-	22	25	ms	5	
Color of CIE Coordinate	W	x	$\theta=0^\circ$ $\Phi=0^\circ$	Typ -0.05	0.302	Typ +0.05	-	1,6
		y			0.326		-	
	R	x			0.638		-	
		y			0.319		-	
	G	x			0.265		-	
		y			0.577		-	
	B	x			0.141		-	
		y			0.091		-	
NTSC Ratio	S	-	70	-	%			

Note: The parameter is slightly changed by temperature, driving voltage and material

Note 1: The data are measured after LEDs are turned on for 5 minutes. LCM displays full white. The brightness is the average value of 9 measured spots. Measurement equipment BM-7 (Φ5mm)

Measuring condition:

- *Measuring surroundings: Dark room.*
- *Measuring temperature: $T_a=25\text{ }^\circ\text{C}$.*
- *Adjust operating voltage to get optimum contrast at the center of the display.*

Measured value at the center point of LCD panel after more than 5 minutes while backlight turning on.

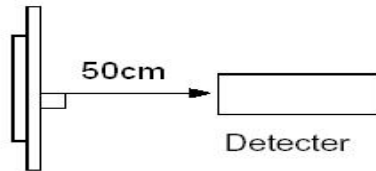

Note 2: The luminance uniformity is calculated by using following formula.

$$\Delta B_p = B_p (\text{Min.}) / B_p (\text{Max.}) \times 100 (\%)$$

$B_p (\text{Max.})$ = Maximum brightness in 9 measured spots

$B_p (\text{Min.})$ = Minimum brightness in 9 measured spots.

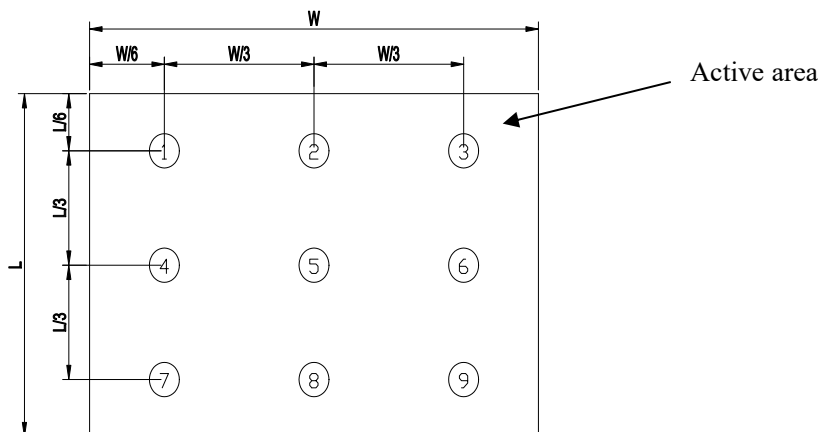

Note 3: The definition of viewing angle:
 Refer to the graph below marked by θ and Φ

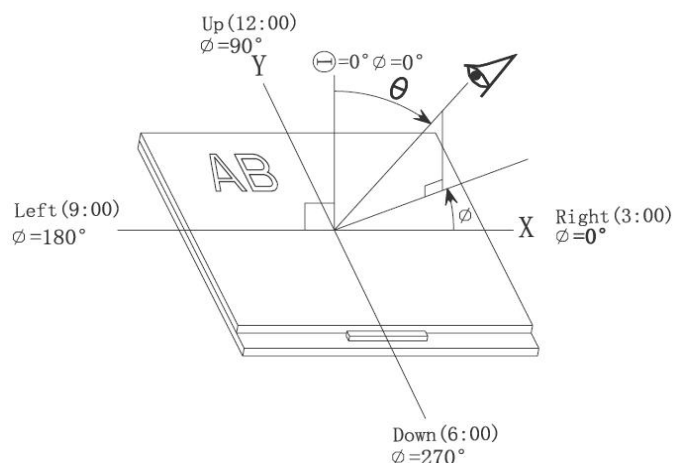

Note 4: Definition of contrast ratio.(Test LCD using DMS501)

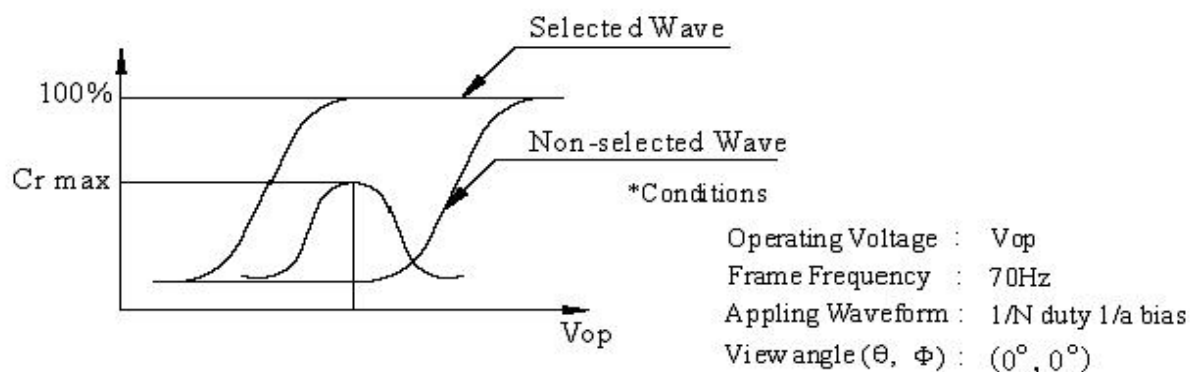

$$\text{Contrast ratio}(Cr) = \frac{\text{Brightness of selected dots}}{\text{Brightness of non-selected dots}}$$

Note 5: Definition of Response time. (Test LCD using DMS501):

The output signals of photo detector are measured when the input signals are changed from "black" to "white" (falling time) and from "white" to "black" (rising time), respectively. The response time is defined as the time interval between the 10% and 90% of amplitudes. Refer to figure as below.

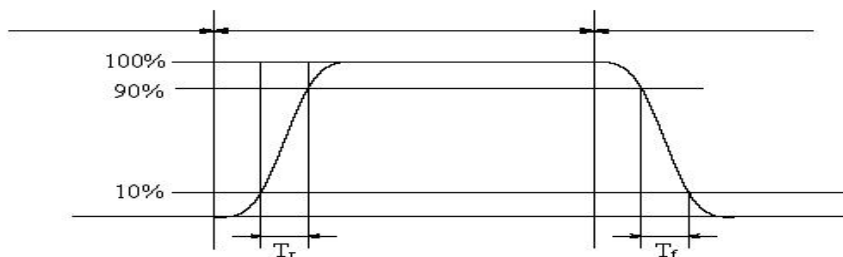

The definition of response time

Note 6: Definition of Color of CIE Coordinate and NTSC Ratio.

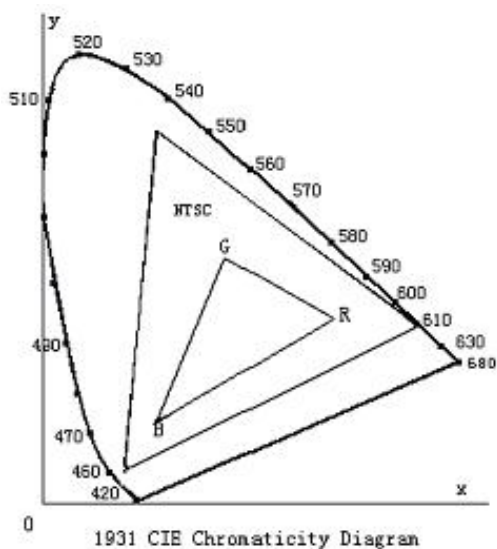

Color gamut:

$$S = \frac{\text{area of RGB triangle}}{\text{area of NTSC triangle}} \times 100\%$$

Note 7: Definition of cross talk.

Cross talk ratio(%) = $\frac{|\text{pattern A Brightness} - \text{pattern B Brightness}|}{\text{pattern A Brightness}} \times 100$

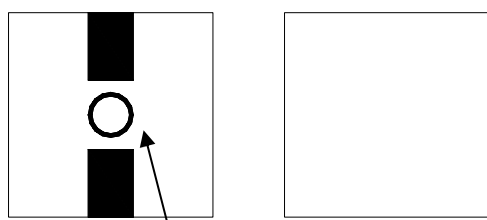

Pattern A

Pattern B

Measurement point(center)

Electric volume value = $3F \pm 3Hex$

8. Reliability Test Items and Criteria

Test Item	Test condition	Remark
High Temperature Storage	Ta = 80°C 240hrs	Note1,Note3, 4
Low Temperature Storage	Ta = -30°C 240hrs	Note1,Note3, 4
High Temperature Operation	Ta = 80°C 240hrs	Note2,Note3, 4
Low Temperature Operation	Ta = -30°C 240hrs	Note1,Note3, 4
Operation at High Temperature/Humidity	+60°C, 90%RH 240hrs	Note3, 4
Thermal Shock	-30°C/30 min ~ +80°C/30 min for a total 50 cycles, Start with cold temperature and end with high temperature.	Note3, 4
Vibration Test	Frequency range:10~55Hz Stroke:1.5mm Sweep:10Hz~55Hz~10Hz 2 hours for each direction of X. Y. Z. (6 hours for total)	
Mechanical Shock (NON-OPERATION)	Shock level: 1470 m/s ² (150G) Waveform: half sinusoidal wave, 2 ms Number of shocks: one shock input in each direction of three mutually perpendicular axes for a total of six shock inputs	
Vibration Test (NON-OPERATION)	Vibration level: 9.8 m/s ² (1.0G) Waveform: sinusoidal Frequency range: 5 to 500 Hz Frequency sweep rate: 0.5 octave /min Duration: one sweep from 5 to 500 Hz in each of three mutually perpendicular axis(each x,y,z axis: 1 hour, total 3 hours)	
Package Drop Test	Height:60cm 1 corner, 3 edges, 6 surfaces	
CONTACT DISCHARGE (OPERATION)	150pF, 330Ω, 8kV, 10 times at 1 sec interval	
SIGNAL PIN DISCHARGE (NON-OPERATION)	200pF, 0Ω, 200V, 10 times at 1 sec interval	

Note 1: T_a is the ambient temperature of samples.

Note 2: T_s is the temperature of panel's surface.

Note 3: In the standard condition, there shall be no practical problem that may affect the display function. After the reliability test, the product only guarantees operation, but don't guarantee all of the cosmetic specification.

Note 4: Before cosmetic and function test, the product must have enough recovery time, at least 2 hours at room temperature

9. Precautions for Use of LCD Modules

9.1 Handling Precautions

9.1.1 *The display panel is made of glass. Do not subject it to a mechanical shock by dropping it from a high place, etc.*

9.1.2 *If the display panel is damaged and the liquid crystal substance inside it leaks out, be sure not to get any in your mouth, if the substance comes into contact with your skin or clothes, promptly wash it off using soap and water.*

9.1.3 *Do not apply excessive force to the display surface or the adjoining areas since this may cause the color tone to vary.*

9.1.4 *The polarizer covering the display surface of the LCD module is soft and easily scratched. Handle this polarizer carefully.*

9.1.5 *If the display surface is contaminated, breathe on the surface and gently wipe it with a soft dry cloth. If still not completely clear, moisten cloth with one of the following solvents:*

— Isopropyl alcohol — Ethyl alcohol

Solvents other than those mentioned above may damage the polarizer. Especially, do not use the following:

— Water — Ketone — Aromatic solvents

9.1.6 *Do not attempt to disassemble the LCD Module.*

9.1.7 *If the logic circuit power is off, do not apply the input signals.*

9.1.8 *To prevent destruction of the elements by static electricity, be careful to maintain an*

optimum work environment.

- a. Be sure to ground the body when handling the LCD Modules.*
- b. Tools required for assembly, such as soldering irons, must be properly ground.*
- c. To reduce the amount of static electricity generated, do not conduct assembly and other work under dry conditions.*
- d. The LCD Module is coated with a film to protect the display surface. Be care when peeling off this protective film since static electricity may be generated.*

9.2 Storage precautions

9.2.1 When storing the LCD modules, avoid exposure to direct sunlight or to the light of fluorescent lamps.

9.2.2 The LCD modules should be stored under the storage temperature range. If the LCD modules will be stored for a long time, the recommend condition is:

Temperature : 0 °C ~ 40 °C

Relatively humidity: ≤80%

9.2.3 The LCD modules should be stored in the room without acid, alkali and harmful gas.

9.3 The LCD modules should be no falling and violent shocking during transportation, and also should avoid excessive press, water, damp and sunshine.

END

Our company network supports you worldwide with offices in Germany, Austria, Switzerland, the UK and the USA. For more information please contact:

Headquarters

Germany



FORTEC Elektronik AG

Augsburger Str. 2b
82110 Germering

Phone: +49 89 894450-0
E-Mail: info@forteca.de
Internet: www.forteca.de

Fortec Group Members

Austria



Distec GmbH Office Vienna

Nuschinggasse 12
1230 Wien

Phone: +43 1 8673492-0
E-Mail: info@distec.de
Internet: www.distec.de

Germany



Distec GmbH

Augsburger Str. 2b
82110 Germering

Phone: +49 89 894363-0
E-Mail: info@distec.de
Internet: www.distec.de

Switzerland



ALTRAC AG

Bahnhofstraße 3
5436 Würenlos

Phone: +41 44 7446111
E-Mail: info@altrac.ch
Internet: www.altrac.ch

United Kingdom



Display Technology Ltd.

Osprey House, 1 Osprey Court
Hichingbrooke Business Park
Huntingdon, Cambridgeshire, PE29 6FN

Phone: +44 1480 411600
E-Mail: info@displaytechnology.co.uk
Internet: www.displaytechnology.co.uk

USA



Apollo Display Technologies, Corp.

87 Raynor Avenue,
Unit 1 Ronkonkoma,
NY 11779

Phone: +1 631 5804360
E-Mail: info@apolloDisplays.com
Internet: www.apolloDisplays.com