



OUR GLOBAL  
COMPETENCE  
CENTRES

 APOLLO DISPLAY  
TECHNOLOGIES



 DISTEC



 DISPLAY  
TECHNOLOGY



# Datasheet

## InnoLux

**G154I1-LE1 Rev.C2**

CH-01-033R1.1

Doc. Number :

- Tentative Specification
- Preliminary Specification
- Approval Specification

**MODEL NO.: G154I1**  
**SUFFIX: LE1**

<b>Customer:</b>	
<b>APPROVED BY</b>	<b>SIGNATURE</b>
<u>Name / Title</u>	_____
Note	
Please return 1 copy for your confirmation with your signature and comments.	

Approved By	Checked By	Prepared By
阮泰郎	林秋森	阮志昌

**CONTENTS**

<b>1. GENERAL DESCRIPTION .....</b>	<b>5</b>
1.1 OVERVIEW .....	5
1.2 FEATURES.....	5
1.3 APPLICATION .....	5
1.4 GENERAL SPECIFICATIONS .....	5
1.5 MECHANICAL SPECIFICATIONS.....	6
<b>2. ABSOLUTE MAXIMUM RATINGS .....</b>	<b>7</b>
2.1 ABSOLUTE RATINGS OF ENVIRONMENT.....	7
2.2 ELECTRICAL ABSOLUTE RATINGS .....	7
2.2.1 TFT LCD MODULE .....	7
2.2.2 BACKLIGHT UNIT.....	7
<b>3. ELECTRICAL CHARACTERISTICS .....</b>	<b>8</b>
3.1 TFT LCD MODULE .....	8
3.2 BACKLIGHT UNIT .....	10
<b>4. BLOCK DIAGRAM .....</b>	<b>11</b>
4.1 TFT LCD MODULE .....	11
<b>5. INPUT TERMINAL PIN ASSIGNMENT .....</b>	<b>12</b>
5.1 TFT LCD MODULE .....	12
5.2 SCANNING DIRECTION .....	13
5.3 COLOR DATA INPUT ASSIGNMENT .....	13
5.3.1 FOR 6-BITS.....	14
5.3.2 FOR 8-BITS.....	15
<b>6. INTERFACE TIMING .....</b>	<b>16</b>
6.1 INPUT SIGNAL TIMING SPECIFICATIONS .....	16
6.2 POWER ON/OFF SEQUENCE.....	17
6.3 THE INPUT DATA FORMAT .....	18
<b>7. OPTICAL CHARACTERISTICS .....</b>	<b>19</b>
7.1 TEST CONDITIONS .....	19
7.2 OPTICAL SPECIFICATIONS.....	19
<b>8. RELIABILITY TEST CRITERIA .....</b>	<b>23</b>
<b>9. PACKAGING.....</b>	<b>24</b>
9.1 PACKING SPECIFICATIONS .....	24
9.2 PACKING METHOD .....	24
<b>10. DEFINITION OF LABELS.....</b>	<b>26</b>
10.1 MODULE LABEL .....	26
10.2 CARTON LABEL.....	27
<b>11. PRECAUTIONS .....</b>	<b>28</b>

11.1 ASSEMBLY AND HANDLING PRECAUTIONS..... 28

11.2 SAFETY PRECAUTIONS ..... 28

**12. MECHANICAL CHARACTERISTICS ..... 28**

**REVISION HISTORY**

Version	Date	Section	Description
Ver 2.0	18th, Mar., 2011	All	G15411-LE1 Approval specification was first issued.
Ver 2.1	12th, Aug., 2011	3.2	Backlight Unit – Added Note (4) Modified PWM Control Duty (Min 20% → 2%) Modified PWM Control Frequency (Max 210→20KHz)
Ver 2.2	28th, Nov., 2011	12	Mechanical Drawing Note(2) Correction to I/F connector part number Note(3) Correction to LED connector part number
Ver 2.3	12th, Dec., 2011	5.3	Add 8bit Data Format
Ver 2.4	28th, Nov., 2016	1.4	Power Consumption Total 11.4W(Max.) BL7.4W (Max.)
		3.2	LED Current 60mA LED Converter Power Consumption 6.2W (Typ.)
		10.1	Module label Company logo from CHI MEI OPTOELECTRONICS to INNOLUX

## 1. GENERAL DESCRIPTION

### 1.1 OVERVIEW

The G154I1-LE1 model is a 15.4" TFT-LCD module with a white LED Backlight Unit and a 30-pin 1ch-LVDS interface. This module supports 1280 x 800 WXGA mode and displays 262k/16.2M colors. The converter for the Backlight Unit is built in..

### 1.2 FEATURES

- WXGA (1280 x 800 pixels) resolution
- Wide operating temperature
- DE (Data Enable) mode
- LVDS (Low Voltage Differential Signaling) interface
- RoHS Compliance
- LED Light Bar Replaceable
- Reverse Scan

### 1.3 APPLICATION

- TFT LCD Monitor
- Industrial Application
- Amusement

### 1.4 GENERAL SPECIFICATIONS

Item	Specification	Unit	Note
Diagonal Size	15.4	inch	(1)
Active Area	331.2(H) x 207.0(V)	mm	-
Bezel Opening Area	334.5 x 210.3	mm	-
Driver Element	a-si TFT active matrix	-	-
Pixel Number	1280 x R.G.B. x 800	pixel	-
Pixel Pitch	0.259(H) x 0.259(V)	mm	-
Pixel Arrangement	RGB vertical stripe	-	-
Display Colors	262k/ 16.2M	color	-
Transmissive Mode	Normally white	-	-
Surface Treatment	AG, 3H	-	-
Luminance, White	450	Cd/m2	
Power Consumption	Total11.4W(Max.) @ cell 4W (Max.),BL7.4W (Max.)		

1.5 MECHANICAL SPECIFICATIONS

Item		Min.	Typ.	Max.	Unit	Note
Module Size	Horizontal (H)	351.5	352	352.5	mm	(1)
	Vertical (V)	229.5	230	230.5	mm	
	Thickness (T)	8.5	9	9.5	mm	
Bezel Area	Horizontal	334.2	334.5	334.8	mm	
	Vertical	210.0	210.3	210.6	mm	
Weight		-	880	-	g	
I/F connector mounting position		The mounting inclination of the connector makes the screen center within $\pm 0.5\text{mm}$ as the horizontal.				(2)

Note (1) Please refer to the attached drawings for more information of front and back outline dimensions

(2) Connector mounting position

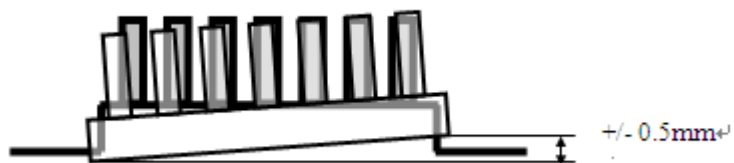



**2. ABSOLUTE MAXIMUM RATINGS**

**2.1 ABSOLUTE RATINGS OF ENVIRONMENT**

Item	Symbol	Value		Unit	Note
		Min.	Max.		
Operating Ambient Temperature	T <sub>OP</sub>	-30	+80	°C	(1), (2)
Storage Temperature	T <sub>ST</sub>	-30	+80	°C	(1)

Note (1): Temperature and relative humidity range is shown in the figure below.

- (a)90 %RH Max. (Ta < 40 °C).
- (b)Wet-bulb temperature should be 39 °C Max. (Ta < 40 °C)
- (c)No condensation

Note(2) :

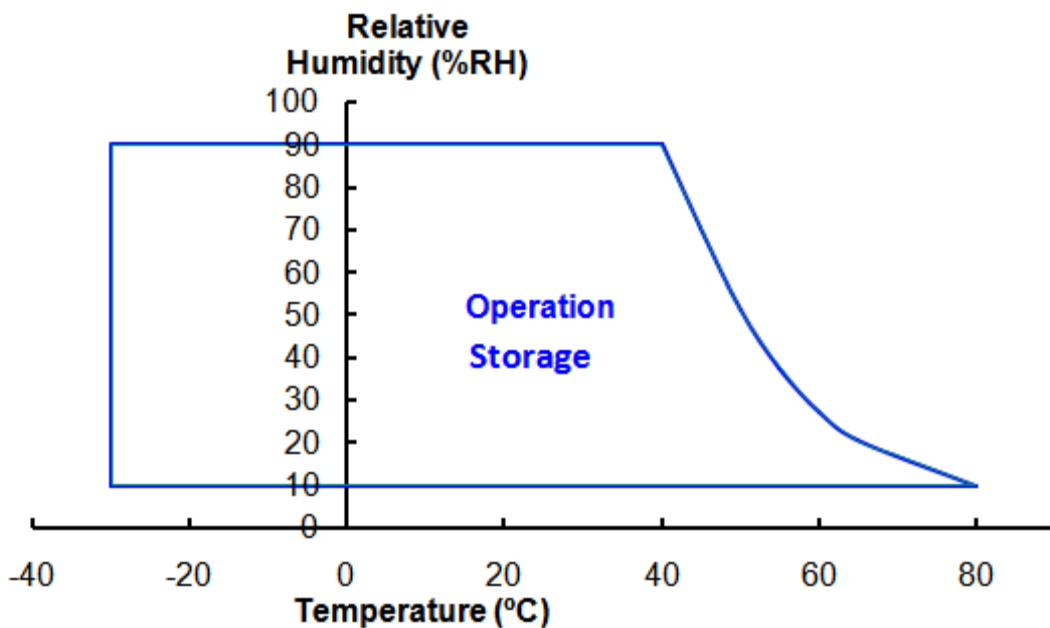

**2.2 ELECTRICAL ABSOLUTE RATINGS**

**2.2.1 TFT LCD MODULE**

Item	Symbol	Value		Unit	Note
		Min.	Max.		
Power Supply Voltage	V <sub>CC</sub>	-0.3	4.0	V	(1)
Logic Input Voltage	V <sub>IN</sub>	-0.3	V <sub>CC</sub> +0.3	V	(1)

**2.2.2 BACKLIGHT UNIT**

Item	Value			Unit	Note
	Min	Typ.	Max.		
LED Light Bar Input voltage	-	28	-	V <sub>DC</sub>	(1), (2)
LED Light Bar Input Current	-	320	-	mA <sub>DC</sub>	

Note (1)Permanent damage to the device may occur if maximum values are exceeded. Function operation should be restricted to the conditions described under Normal Operating Conditions.

Note (2) Specified values are for LED (Refer to Section 3.2 for further information).

3. ELECTRICAL CHARACTERISTICS

3.1 TFT LCD MODULE

Ta = 25 ± 2 °C

Parameter	Symbol	Value			Unit	Note	
		Min.	Typ.	Max.			
Power Supply Voltage	Vcc	3.0	3.3	3.6	V	at Vcc=3.3V	
Ripple Voltage	V <sub>RP</sub>	-	50		mV	-	
Rush Current	I <sub>RUSH</sub>	-	-	1.5	A	(2)	
Initial Stage Current	I <sub>IS</sub>	-	-	1.0	A	(2)	
Power Supply Current	White	I <sub>CC</sub>	-	400	500	mA	(3)a, at Vcc=3.3V
	Black		-	550	650	mA	(3)b, at Vcc=3.3V
LVDS Differential Input High Threshold	V <sub>TH</sub> (LVDS)	-	-	+100	mV	VCM=1.2V	
LVDS Differential Input Low Threshold	V <sub>TL</sub> (LVDS)	-100	-	-	mV	VCM=1.2V	
LVDS Common Mode Voltage	V <sub>CM</sub>	1.125	-	1.375	V		
LVDS Differential Input Voltage	V <sub>ID</sub>	100	-	600	mV		
Terminating Resistor	R <sub>T</sub>	-	100	-	Ohm		

Note (1) The assembly should be always operated within above ranges.

Note (2) Measurement Conditions:

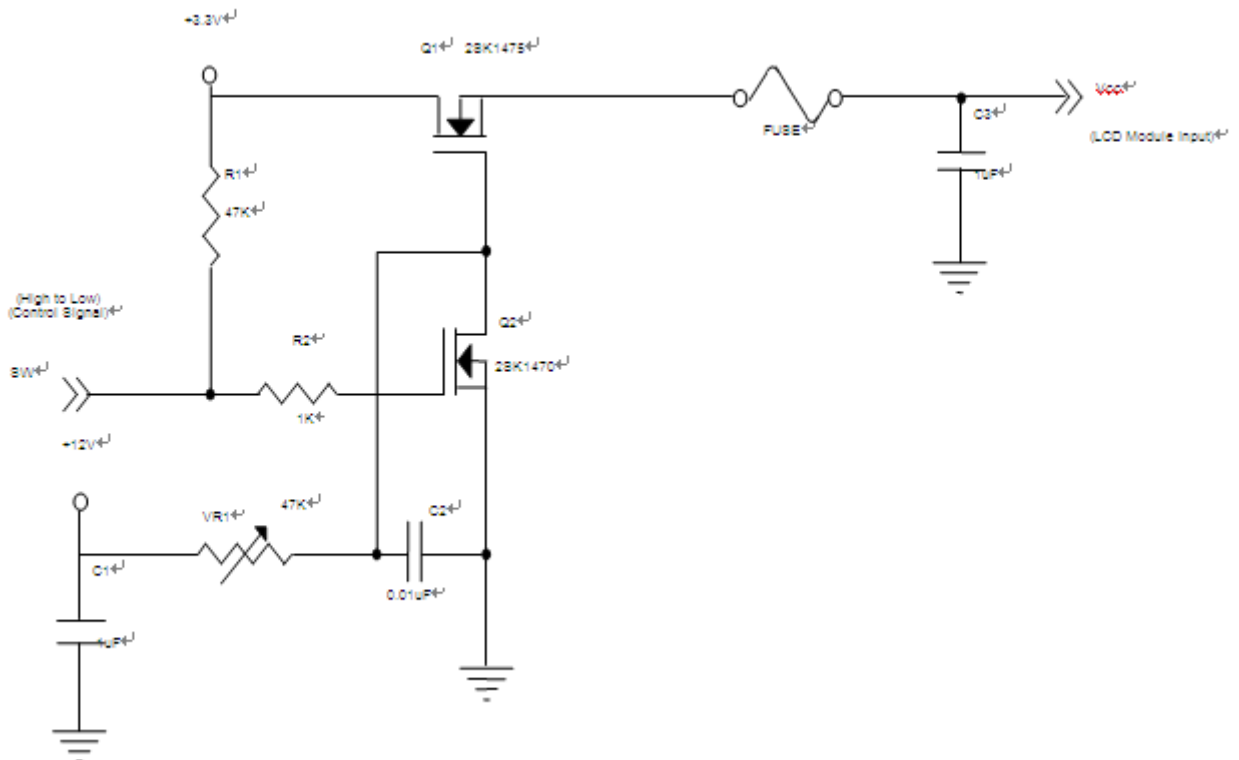

VCC rising time is 470us

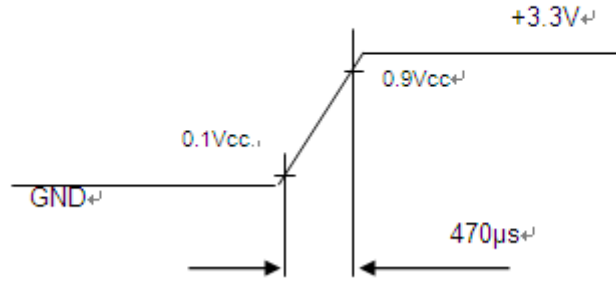

Note (3) The specified power supply current is under the conditions at V<sub>cc</sub> = 3.3 V, T<sub>a</sub> = 25 ± 2 °C, f<sub>v</sub> = 60 Hz, whereas a power dissipation check pattern below is displayed.

a. White Pattern

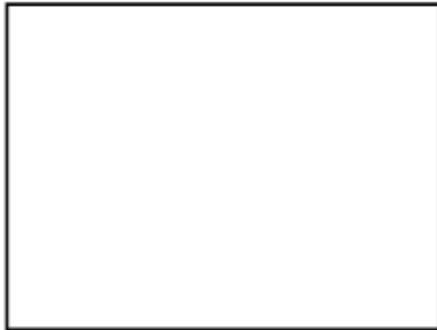

Active Area

b. Black Pattern



Active Area

c. Vertical Stripe Pattern

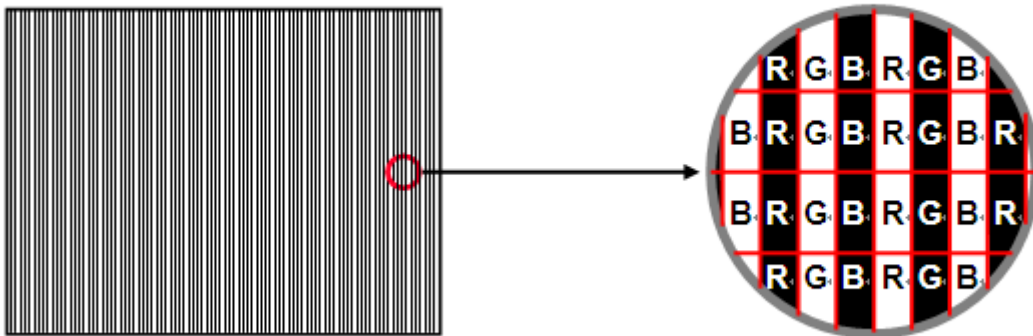

Active Area

**3.2 BACKLIGHT UNIT**

Ta = 25 ± 2 °C

Parameter	Symbol	Value			Unit	Note
		Min.	Typ.	Max.		
Converter Power Supply Voltage	V <sub>i</sub>	10.8	12.0	13.2	V	(Duty 100%)
Converter Power Supply Current	I <sub>i</sub>	420	520	620	mA	@ Vi = 12V (Duty 100%)
LED Power Consumption	P <sub>LED</sub>	5.0	6.2	7.4	W	@ Vi = 12V (Duty 100%),(3)
EN Control Level	Backlight on	2.0	3.3	5.0	V	
	Backlight off	0	---	0.8	V	
PWM Control Level	PWM High Level	2.0	3.3	5.0	V	
	PWM Low Level	0	---	0.15	V	
PWM Control Duty Ratio		2		100	%	@200Hz, (4)
PWM Control Frequency	f <sub>PWM</sub>	190	200	20K	Hz	(4)
LED Input Voltage	V <sub>f</sub>		2.9		V <sub>DC</sub>	If= 60 mA/EA
LED Current	I <sub>f</sub>		60		mA	Per EA
LED Life Time	L <sub>L</sub>	50,000			Hrs	(1)

Note (1) LED current is measured by utilizing a high frequency current meter as shown below:

Note (2) The lifetime of LED is estimated data and defined as the time when it continues to operate under the conditions at Ta = 25 ±2 °C and I<sub>LED</sub> = 60mADC(LED forward current) until the brightness becomes ≤ 50% of its original value. Operating LED under high temperature environment will reduce life time and lead to color shift

Note (3) P<sub>L</sub> = I<sub>o</sub> × V<sub>o</sub>

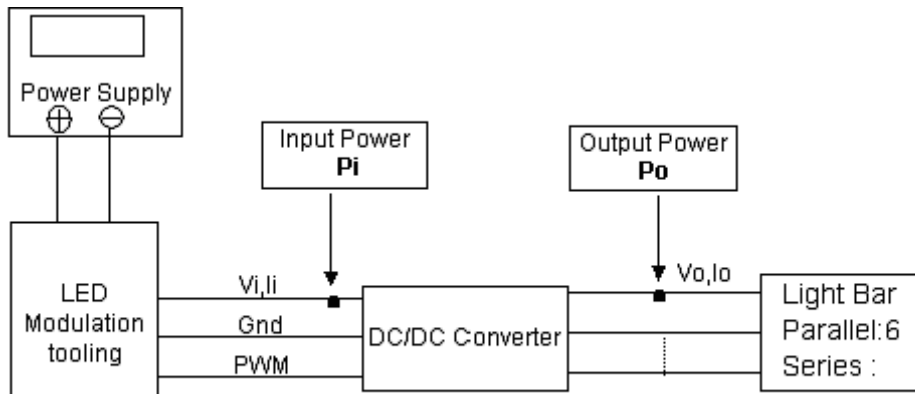

Note (4) :At 190 ~1KHz PWM control frequency, duty ratio range is restricted from 2% to 100%.

1K ~20KHz PWM control frequency · minimum duty on-time ≥ 20 us.

4. BLOCK DIAGRAM

4.1 TFT LCD MODULE

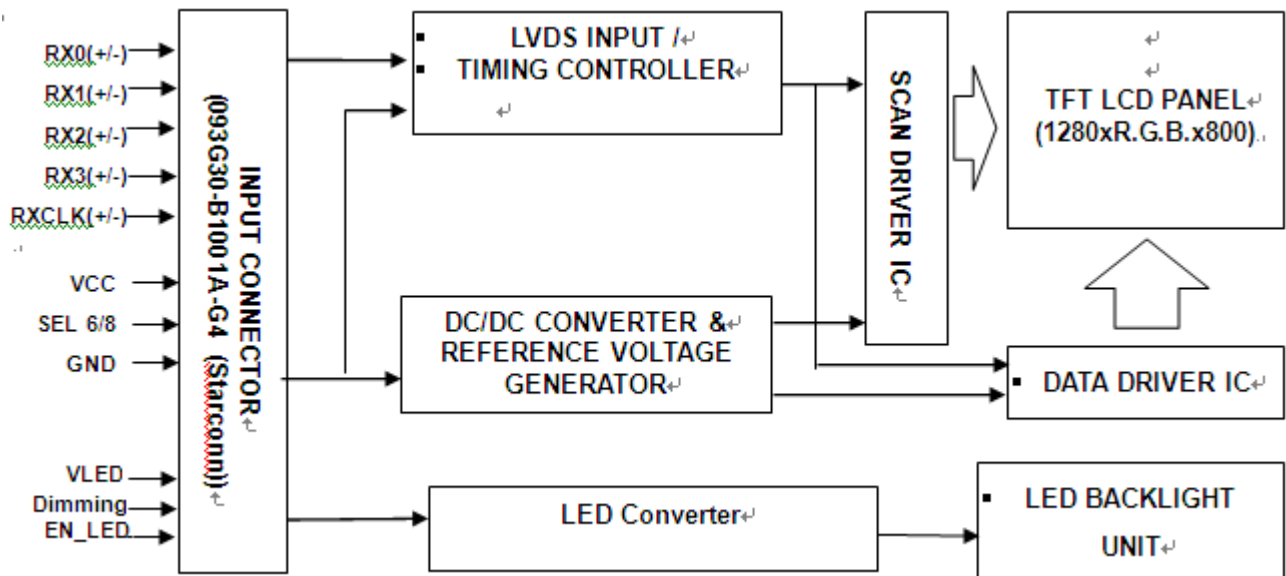

## 5. INPUT TERMINAL PIN ASSIGNMENT

### 5.1 TFT LCD MODULE

Pin	Name	Description	Remark
1	12V	LED Power supply	LED converter power
2	12V	LED Power supply	
3	12V	LED Power supply	
4	12V	LED Power supply	
5	ENLED	Enable Pin	
6	Dimming	Backlight Adjust	
7	GND	Ground	
8	GND	Ground	
9	VCC	Power supply +3.3V	System power
10	VCC	Power supply +3.3V	
11	GND	Ground	
12	GND	Ground	
13	RX0-	Differential Data Input, CH0 ( Negative )	
14	RX0+	Differential Data Input, CH0 ( Positive )	
15	GND	Ground	
16	RX1-	Differential Data Input, CH1 ( Negative )	
17	RX1+	Differential Data Input , CH1 ( Positive )	
18	GND	Ground	
19	RX2-	Differential Data Input , CH2 ( Negative )	
20	RX2+	Differential Data Input , CH2 ( Positive )	
21	GND	Ground	
22	RXCLK-	Differential Clock Input ( Negative )	
23	RXCLK+	Differential Clock Input ( Positive )	
24	GND	Ground	
25	RX3-	Differential Data Input, CH3 ( Negative )	
26	RX3+	Differential Data Input, CH3 ( Positive )	
27	GND	Ground	
28	SEL6/8	LVDS 6/8 bit select function control, Low or NC → 6 bit Input Mode High → 8 bit Input Mode	(2)
29	Reverse	Scanning direction control	(2)
		Low or NC → normal display (default) High → display with 180 degree rotation	
30	GND	Ground	

Note (1) Connector Part No.: STARCONN 093G30-B1001A-G4 or equivalent.

Note (2) "Low" stands for 0V. "High" stands for 3.3V. "NC" stands for "No Connected".

### 5.2 SCANNING DIRECTION

The following figures are seen from a front view and the arrow shows the direction of scan.

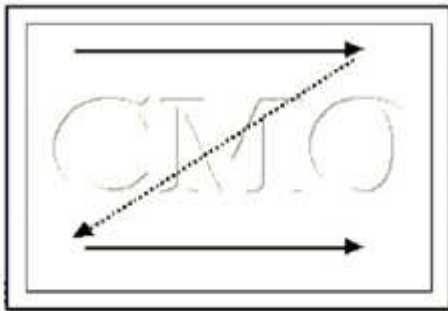

Reverse = GND/NC : normal display (default)

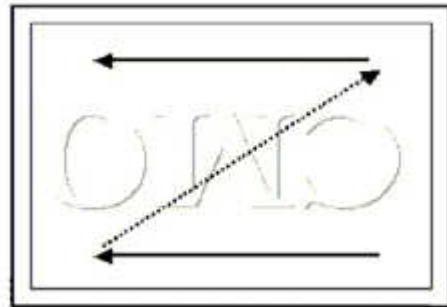

Reverse = High : display with 180 degree rotation

### 5.3 COLOR DATA INPUT ASSIGNMENT

The brightness of each primary color (red, green and blue) is based on the 6/8-bit gray scale data input for the color. The higher the binary input, the brighter the color. The table below provides the assignment of color versus data input.

**5.3.1 FOR 6-BITS**

Color		Data Signal																	
		Red						Green						Blue					
		R5	R4	R3	R2	R1	R0	G5	G4	G3	G2	G1	G0	B5	B4	B3	B2	B1	B0
Basic Colors	Black	0	0	0	0	0	0	0	0	0	0	0	0	0	0	0	0	0	0
	Red	1	1	1	1	1	1	0	0	0	0	0	0	0	0	0	0	0	0
	Green	0	0	0	0	0	0	1	1	1	1	1	1	0	0	0	0	0	0
	Blue	0	0	0	0	0	0	0	0	0	0	0	0	1	1	1	1	1	1
	Cyan	0	0	0	0	0	0	1	1	1	1	1	1	1	1	1	1	1	1
	Magenta	1	1	1	1	1	1	0	0	0	0	0	0	1	1	1	1	1	1
	Yellow	1	1	1	1	1	1	1	1	1	1	1	1	0	0	0	0	0	0
	White	1	1	1	1	1	1	1	1	1	1	1	1	1	1	1	1	1	1
Gray Scale Of Red	Red(0)/Dark	0	0	0	0	0	0	0	0	0	0	0	0	0	0	0	0	0	0
	Red(1)	0	0	0	0	0	1	0	0	0	0	0	0	0	0	0	0	0	0
	Red(2)	0	0	0	0	1	0	0	0	0	0	0	0	0	0	0	0	0	0
	:	:	:	:	:	:	:	0	0	0	0	0	0	0	0	0	0	0	0
	:	:	:	:	:	:	:	0	0	0	0	0	0	0	0	0	0	0	0
	:	:	:	:	:	:	:	0	0	0	0	0	0	0	0	0	0	0	0
	Red(61)	1	1	1	1	0	1	0	0	0	0	0	0	0	0	0	0	0	0
	Red(62)	1	1	1	1	1	0	0	0	0	0	0	0	0	0	0	0	0	0
Red(63)	1	1	1	1	1	1	0	0	0	0	0	0	0	0	0	0	0	0	
Gray Scale Of Green	Green(0)/Dark	0	0	0	0	0	0	0	0	0	0	0	0	0	0	0	0	0	0
	Green(1)	0	0	0	0	0	0	0	0	0	0	0	1	0	0	0	0	0	0
	Green(2)	0	0	0	0	0	0	0	0	0	0	1	0	0	0	0	0	0	0
	:	0	0	0	0	0	0	:	:	:	:	:	:	0	0	0	0	0	0
	:	0	0	0	0	0	0	:	:	:	:	:	:	0	0	0	0	0	0
	:	0	0	0	0	0	0	:	:	:	:	:	:	0	0	0	0	0	0
	Green(61)	0	0	0	0	0	0	1	1	1	1	0	1	0	0	0	0	0	0
	Green(62)	0	0	0	0	0	0	1	1	1	1	1	0	0	0	0	0	0	0
Green(63)	0	0	0	0	0	0	1	1	1	1	1	1	0	0	0	0	0	0	
Gray Scale Of Blue	Blue(0)/Dark	0	0	0	0	0	0	0	0	0	0	0	0	0	0	0	0	0	0
	Blue(1)	0	0	0	0	0	0	0	0	0	0	0	0	0	0	0	0	0	1
	Blue(2)	0	0	0	0	0	0	0	0	0	0	0	0	0	0	0	0	1	0
	:	0	0	0	0	0	0	0	0	0	0	0	0	:	:	:	:	:	:
	:	0	0	0	0	0	0	0	0	0	0	0	0	:	:	:	:	:	:
	:	0	0	0	0	0	0	0	0	0	0	0	0	:	:	:	:	:	:
	Blue(61)	0	0	0	0	0	0	0	0	0	0	0	0	1	1	1	1	0	1
	Blue(62)	0	0	0	0	0	0	0	0	0	0	0	0	1	1	1	1	1	0
Blue(63)	0	0	0	0	0	0	0	0	0	0	0	0	1	1	1	1	1	1	





**6. INTERFACE TIMING**

**6.1 INPUT SIGNAL TIMING SPECIFICATIONS**

The input signal timing specifications are shown as the following table and timing diagram.

Signal	Item	Symbol	Min.	Typ.	Max.	Unit	Note
DCLK	Frequency	1/Tc	67.45	71	74.55	MHz	-
DE	Vertical Total Time	TV	810	823	1000	TH	-
	Vertical Addressing Time	TVD	800	800	800	TH	-
	Horizontal Total Time	TH	1360	1440	1600	Tc	-
	Horizontal Addressing Time	THD	1280	1280	1280	Tc	-

Note : (1)Because this module is operated by DE only mode, Hsync and Vsync input signals should be set to low logic level or ground. Otherwise, this module would operate abnormally.

**INPUT SIGNAL TIMING DIAGRAM**

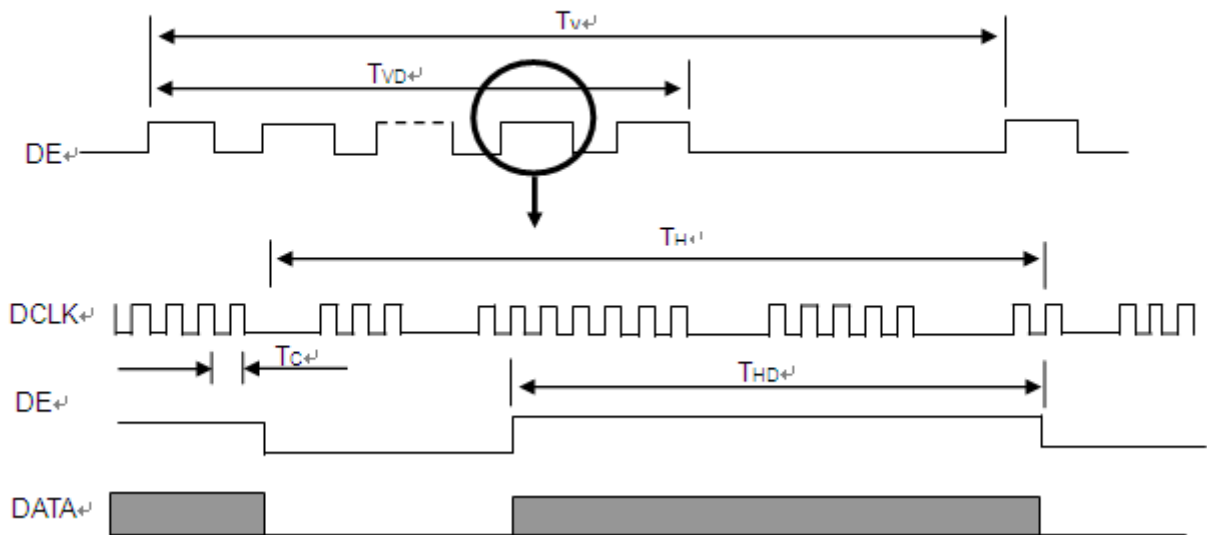

**6.2 POWER ON/OFF SEQUENCE**

To prevent a latch-up or DC operation of LCD assembly, the power on/off sequence should be as the diagram below.

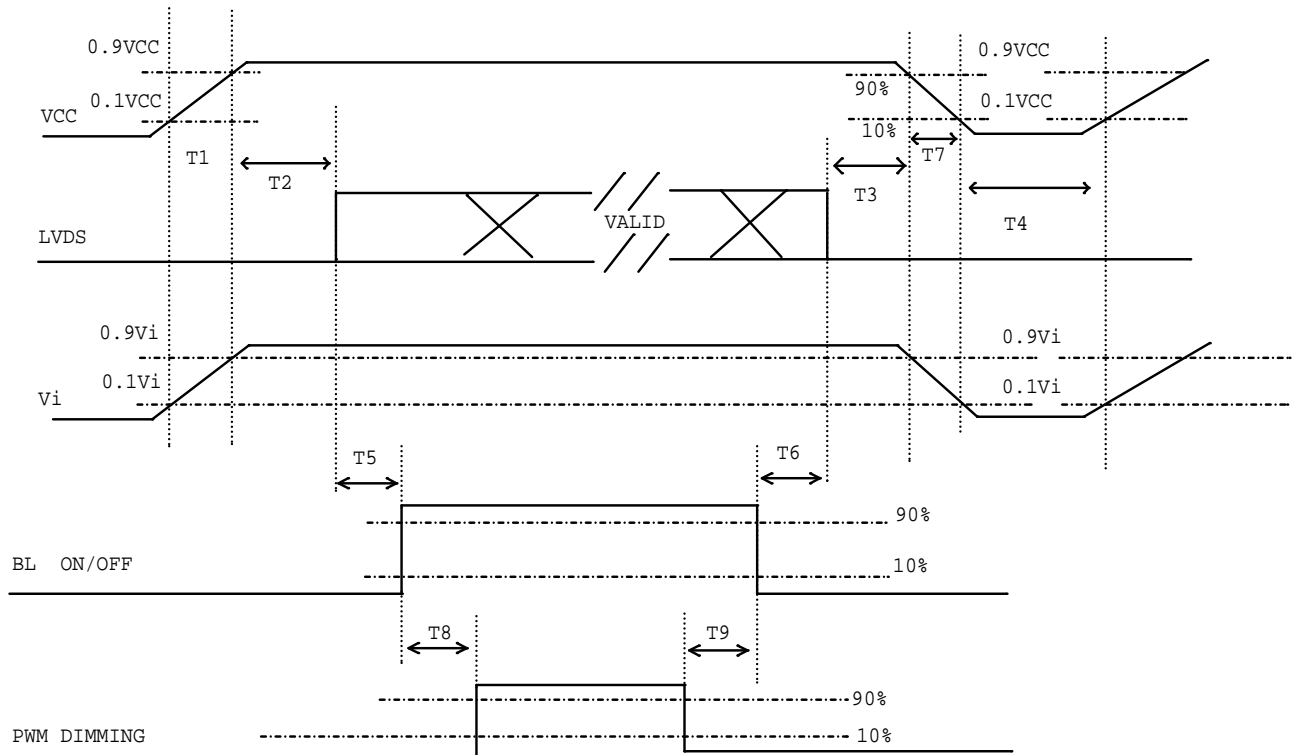

**Power ON/OFF sequence**

Note (1) Please avoid floating state of interface signal at invalid period.

Note (2) When the interface signal is invalid, be sure to pull down the power supply of LCD VCC to 0 V.

Note (3) The Backlight converter power must be turned on after the power supply for the logic and the interface signal is valid. The Backlight converter power must be turned off before the power supply for the logic and the interface signal is invalid.

Parameter	Value			Units
	Min	Typ	Max	
T1	0.5	-	10	ms
T2	0	-	50	ms
T3	0	-	50	ms
T4	500	-	-	ms
T5	200	-	-	ms
T6	20	-	-	ms
T7	5	-	300	ms
T8	10	-	-	ms
T9	10	-	-	ms

6.3 THE INPUT DATA FORMAT

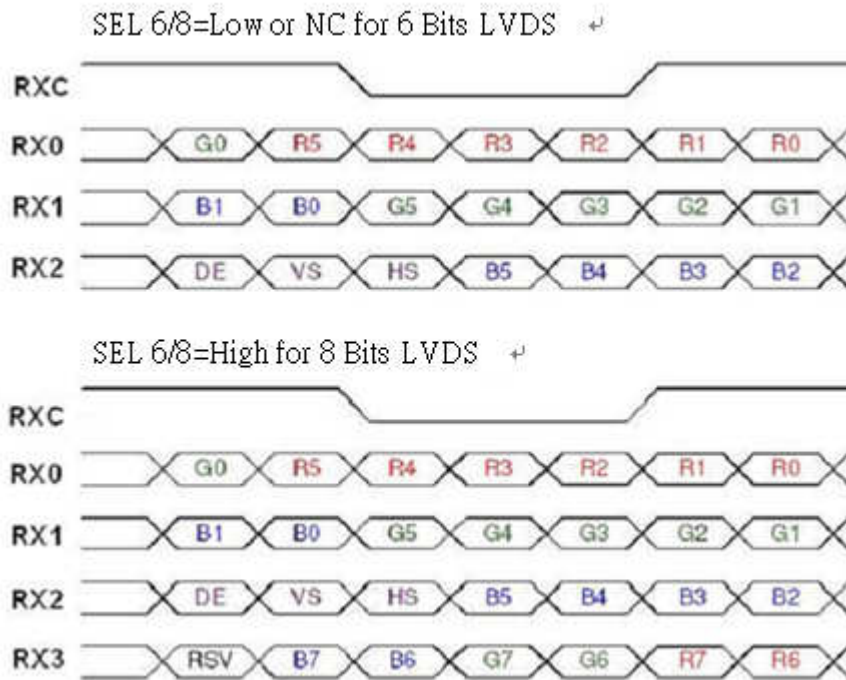

Note (1) R/G/B data 7: MSB, R/G/B data 0: LSB

Note (2) Please follow PSWG

Signal Name	Description	Remark
R7	Red Data 7 (MSB)	Red-pixel Data Each red pixel's brightness data consists of these 8 bits pixel data.
R6	Red Data 6	
R5	Red Data 5	
R4	Red Data 4	
R3	Red Data 3	
R2	Red Data 2	
R1	Red Data 1	
R0	Red Data 0 (LSB)	
G7	Green Data 7 (MSB)	Green-pixel Data Each green pixel's brightness data consists of these 8 bits pixel data.
G6	GreenData 6	
G5	GreenData 5	
G4	GreenData 4	
G3	GreenData 3	
G2	GreenData 2	
G1	GreenData 1	
G0	GreenData 0 (LSB)	
B7	Blue Data 7 (MSB)	Blue-pixel Data Each blue pixel's brightness data consists of these 8 bits pixel data.
B6	Blue Data 6	
B5	Blue Data 5	
B4	Blue Data 4	
B3	Blue Data 3	
B2	Blue Data 2	
B1	Blue Data 1	
B0	Blue Data 0 (LSB)	
RXCLKIN+ RXCLKIN-	LVDS Clock Input	
DE	Display Enable	
VS	Vertical Sync	
HS	Horizontal Sync	

## 7. OPTICAL CHARACTERISTICS

### 7.1 TEST CONDITIONS

Item	Value	Unit
Ambient Temperature (Ta)	25±2	°C
Ambient Humidity (Ha)	50±10	%RH
Supply Voltage	According to typical value in "ELECTRICAL CHARACTERISTICS"	
Input Signal		
LED Light Bar Input Current Per Input Pin		

### 7.2 OPTICAL SPECIFICATIONS

The relative measurement methods of optical characteristics are shown in 7.2 and all items are measured at the center point of screen except white variation. The following items should be measured under the test conditions described in 7.1 and stable environment shown in Note (5).

Item	Symbol	Condition	Min.	Typ.	Max.	Unit	Note
Contrast Ratio	CR	$\theta_x=0^\circ, \theta_y=0^\circ$ Viewing Normal Angle	500	700	-	-	(2), (5)
Response Time	$T_R$		-	5	10	ms	(3)
	$T_F$		-	11	16	ms	
Luminance of White	$L_c$		350	450	-	cd/m <sup>2</sup>	(4), (5)
White Variation	$\delta W$		-	1.25	1.4	-	(5), (6)
Color Chromaticity	Red		Rx	Typ. +0.05	0.601	Typ. +0.05	-
		Ry	0.340		-		
	Green	Gx	0.332		-		
		Gy	0.583		-		
	Blue	Bx	0.149		-		
		By	0.087		-		
	White	Wx	0.313		-		
		Wy	0.329		-		
Viewing Angle	Horizontal	$\theta_{x+}$	70	80	-	Deg.	(1), (5)
		$\theta_{x-}$	70	80	-		
	Vertical	$\theta_{y+}$	60	70	-		
		$\theta_{y-}$	60	70	-		

Note (1) Definition of Viewing Angle ( $\theta_x, \theta_y$ ):

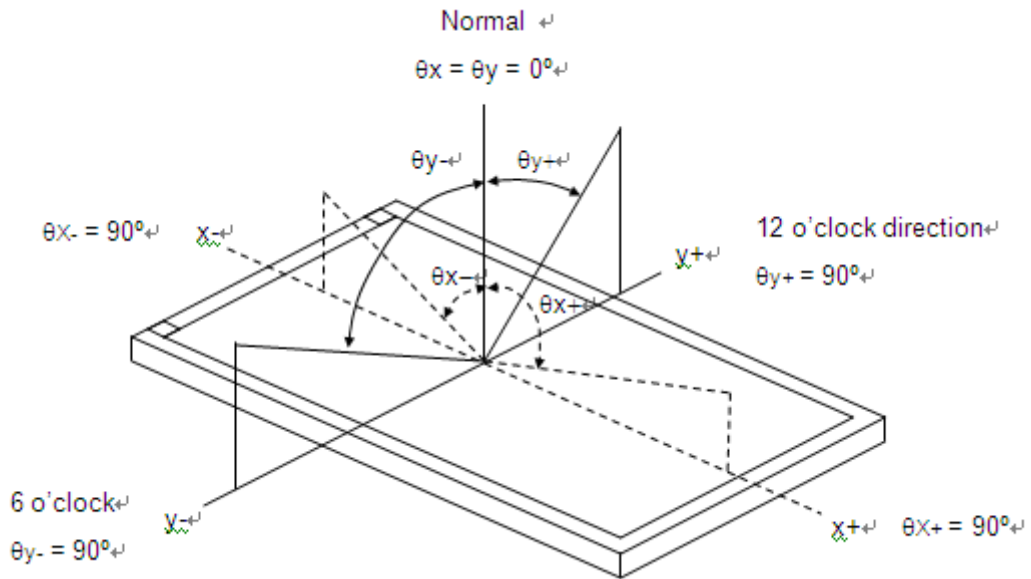

Note (2) Definition of Contrast Ratio (CR):

The contrast ratio can be calculated by the following expression.

$$\text{Contrast Ratio (CR)} = L_{63} / L_0$$

L63: Luminance of gray level 63

L 0: Luminance of gray level 0

$$\text{CR} = \text{CR} (5)$$

CR (X) is corresponding to the Contrast Ratio of the point X at Figure in Note (6).

Note (3) Definition of Response Time ( $T_R, T_F$ ) and measurement method:

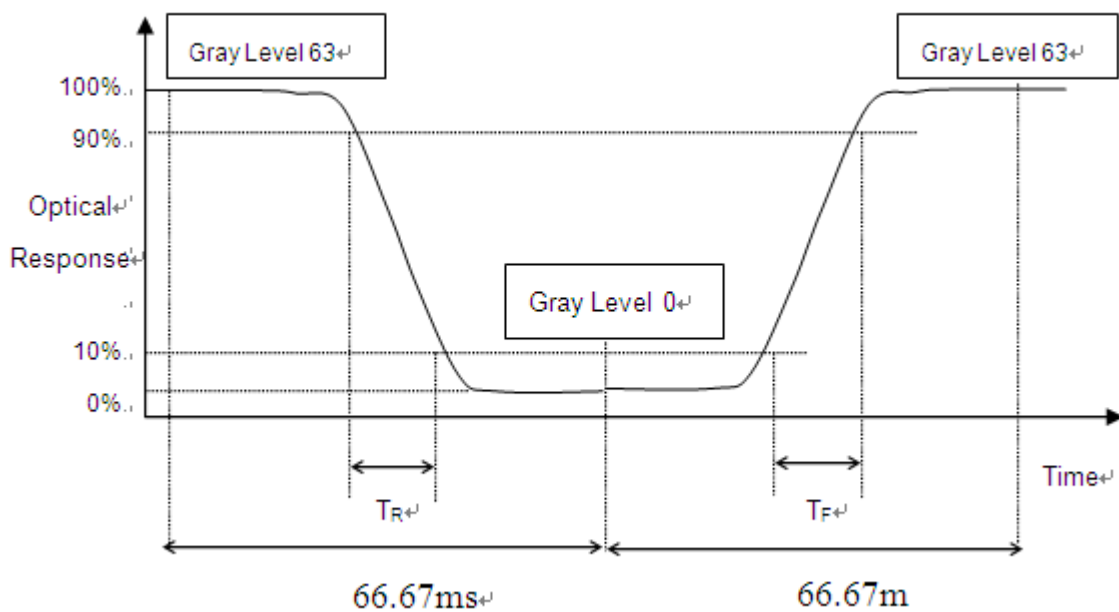

Note (4) Definition of Luminance of White ( $L_C$ ):

Measure the luminance of gray level 63 at center point

$$L_C = L(5)$$

$L(x)$  is corresponding to the luminance of the point X at Figure in Note (6).

Note (5) Measurement Setup:

The LCD module should be stabilized at given temperature for 20 minutes to avoid abrupt temperature change during measuring. In order to stabilize the luminance, the measurement should be executed after lighting Backlight for 20 minutes in a windless room.

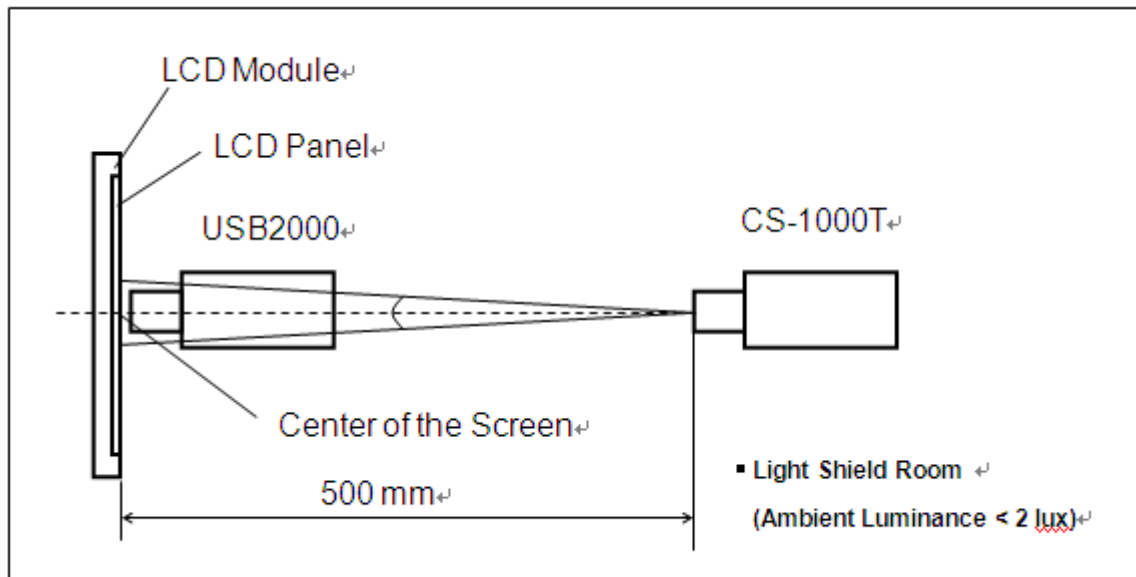

Note (6) Definition of White Variation ( $\delta W$ ):

Measure the luminance of gray level 63 at 5 points

$$\delta W = \frac{\text{Maximum } [L(1), L(2), L(3), L(4), L(5)]}{\text{Minimum } [L(1), L(2), L(3), L(4), L(5)]}$$

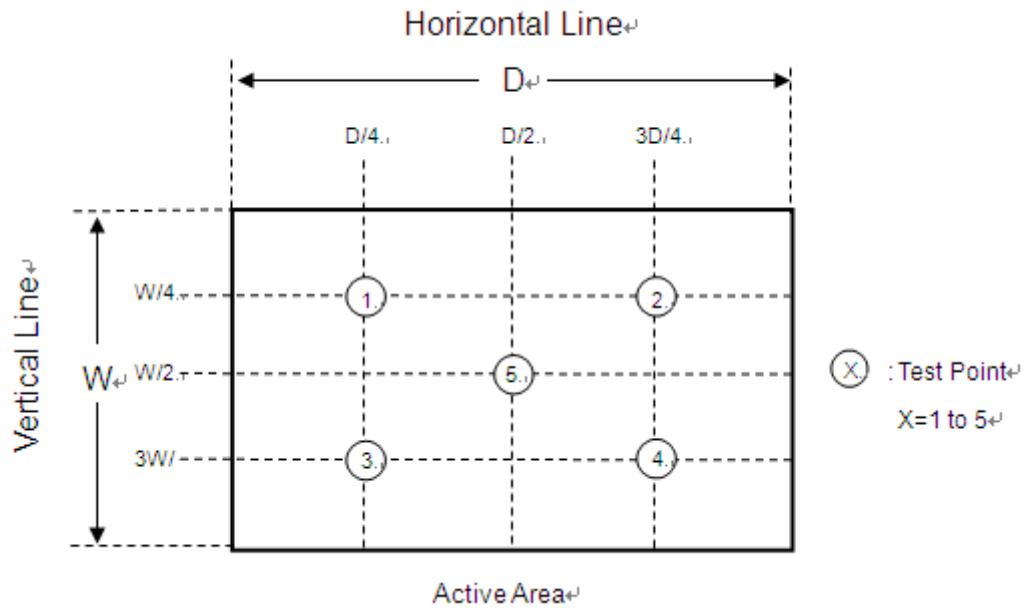



## 8. RELIABILITY TEST CRITERIA

Test Item	Test Condition	Note
High Temperature Storage Test	80°C, 240 hours	(1)(2)(4)
Low Temperature Storage Test	-30°C, 240hours	
Thermal Shock Storage Test	-30°C, 0.5hour←→80°C, 0.5hour; 1hour/cycle, 100cycles	
High Temperature Operation Test	80°C, 240 hours	
Low Temperature Operation Test	-30°C, 240 hours	
High Temperature & High Humidity Operation Test	60°C, 90%RH, 240hours	
Shock (Non-Operating)	50G, 11ms, half sine wave, 1time for each direction of $\pm X$ , $\pm Y$ , $\pm Z$	(3)(4)
Vibration (Non-Operating)	1.5G 10~300hz sine wave, 10min/cycle, 3cycles, each X, Y, Z direction	(3)(4)

Note (1) There should be no condensation on the surface of panel during test.

Note (2) Temperature of panel display surface area should be 80 °C Max.

Note (3) At testing Vibration and Shock, the fixture in holding the module has to be hard and rigid enough so that the module would not be twisted or bent by the fixture.

Note (4) In the standard conditions, there is no function failure issue occurred. All the cosmetic specification is judged before reliability test.

**9. PACKAGING**

**9.1 PACKING SPECIFICATIONS**

- (1) 13pcs LCD modules / 1 Box
- (2) Box dimensions: 465(L) X 362 (W) X 314 (H) mm
- (3) Weight: approximately 11 Kg (13 modules per box)

**9.2 PACKING METHOD**

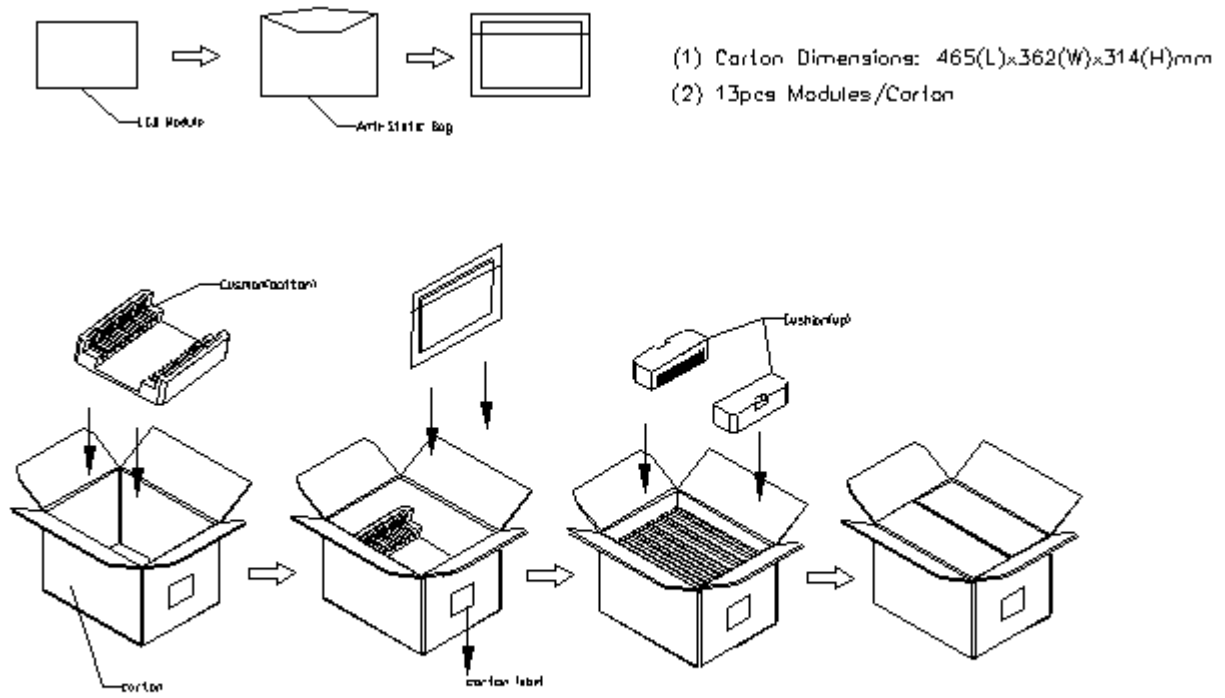

▪ **Figure 9-1 Packing method**

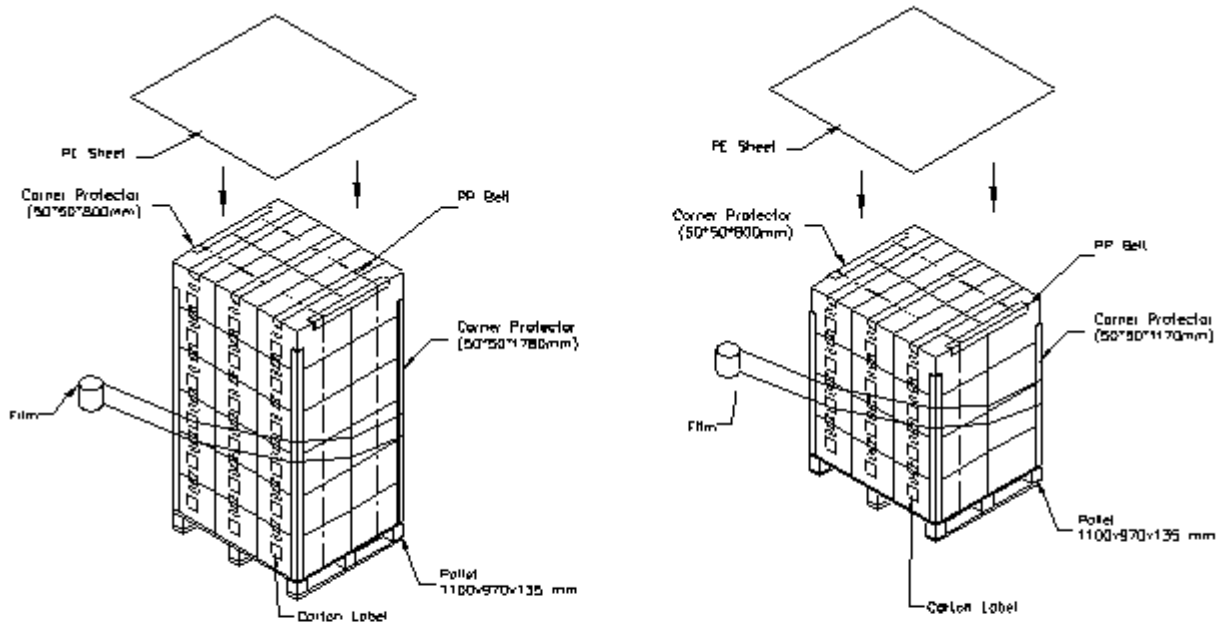

▪ Figure. 9-2 Packing method

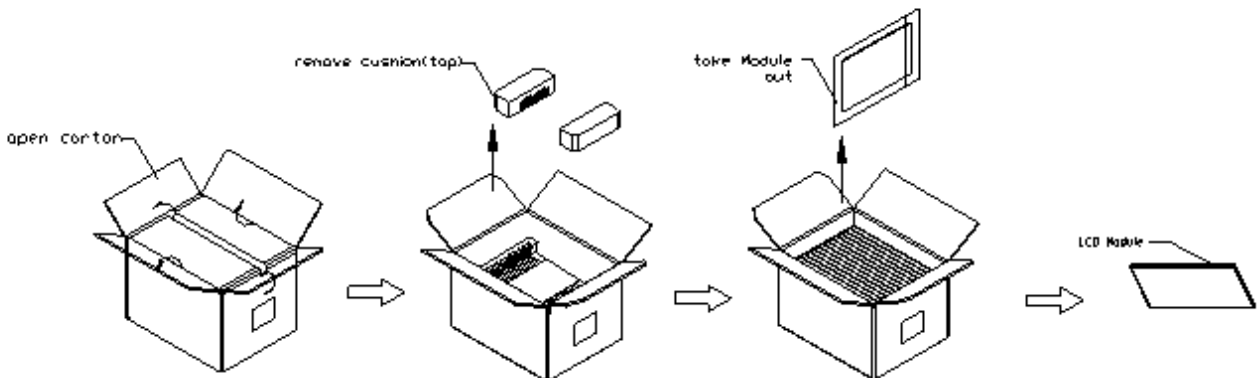

▪ Figure. 9-3 Un-Packing method

**10. DEFINITION OF LABELS**

**10.1 MODULE LABEL**

The barcode nameplate is pasted on each module as illustration, and its definitions are as following explanation.



- (a) Model Name: G154I1 –LE1
- (b) Revision: Rev. XX, for example: A1, ...C1, C2 ...etc.
- (c) Serial ID: X X X X X X Y M D X N N N N

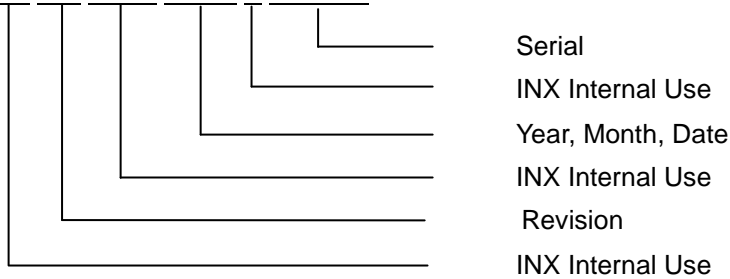

Serial ID includes the information as below:

- (a) Manufactured Date: Year: 0~9, for 2010~2019  
 Month: 1~9, A~C, for Jan. ~ Dec.  
 Day: 1~9, A~Y, for 1<sup>st</sup> to 31<sup>st</sup>, exclude I , O and U
- (b) Revision Code: cover all the change
- (c) Serial No.: Manufacturing sequence of product

10.2 CARTON LABEL

<b>INNOLUX</b>	
PO.NO. _____	
Part ID. _____	
Model Name <b>G15411-LE1 Rev.XX</b> _____	
Carton ID. _____	Quantities _____
XXXXXXXXXXXXXXXXXXXX	
<b>Made in Taiwan</b>	
<b>GP</b> <b>RoHS</b>	

- (a) P/N: Internal control
- (b) Model Name: G15411-LE1
- (c) Production year and month: shown at left down corner
- (d) Production location: Made In XXXX. XXXX stands for production location.

**11. PRECAUTIONS****11.1 ASSEMBLY AND HANDLING PRECAUTIONS**

- (1) Do not apply rough force such as bending or twisting to the module during assembly.
- (2) To assemble or install module into user's system can be only in clean working areas. The dust and oil may cause electrical short or worsen the polarizer.
- (3) It's not permitted to have pressure or impulse on the module because the LCD panel and Backlight will be damaged.
- (4) Always follow the correct power sequence when LCD module is connecting and operating. This can prevent damage to the CMOS LSI chips during latch-up.
- (5) Do not pull the I/F connector in or out while the module is operating.
- (6) Do not disassemble the module.
- (7) Use a soft dry cloth without chemicals for cleaning, because the surface of polarizer is very soft and easily scratched.
- (8) It is dangerous that moisture come into or contacted the LCD module, because moisture may damage LCD module when it is operating.
- (9) High temperature or humidity may reduce the performance of module. Please store LCD module within the specified storage conditions.
- (10) When ambient temperature is lower than 10°C may reduce the display quality. For example, the response time will become slowly.
- (11) Do not keep same pattern in a long period of time. It may cause image sticking on LCD.

**11.2 SAFETY PRECAUTIONS**

- (1) Do not disassemble the module or insert anything into the Backlight unit.
- (2) If the liquid crystal material leaks from the panel, it should be kept away from the eyes or mouth. In case of contact with hands, skin or clothes, it has to be washed away thoroughly with soap.
- (3) After the module's end of life, it is not harmful in case of normal operation and storage.

**12. MECHANICAL CHARACTERISTICS**

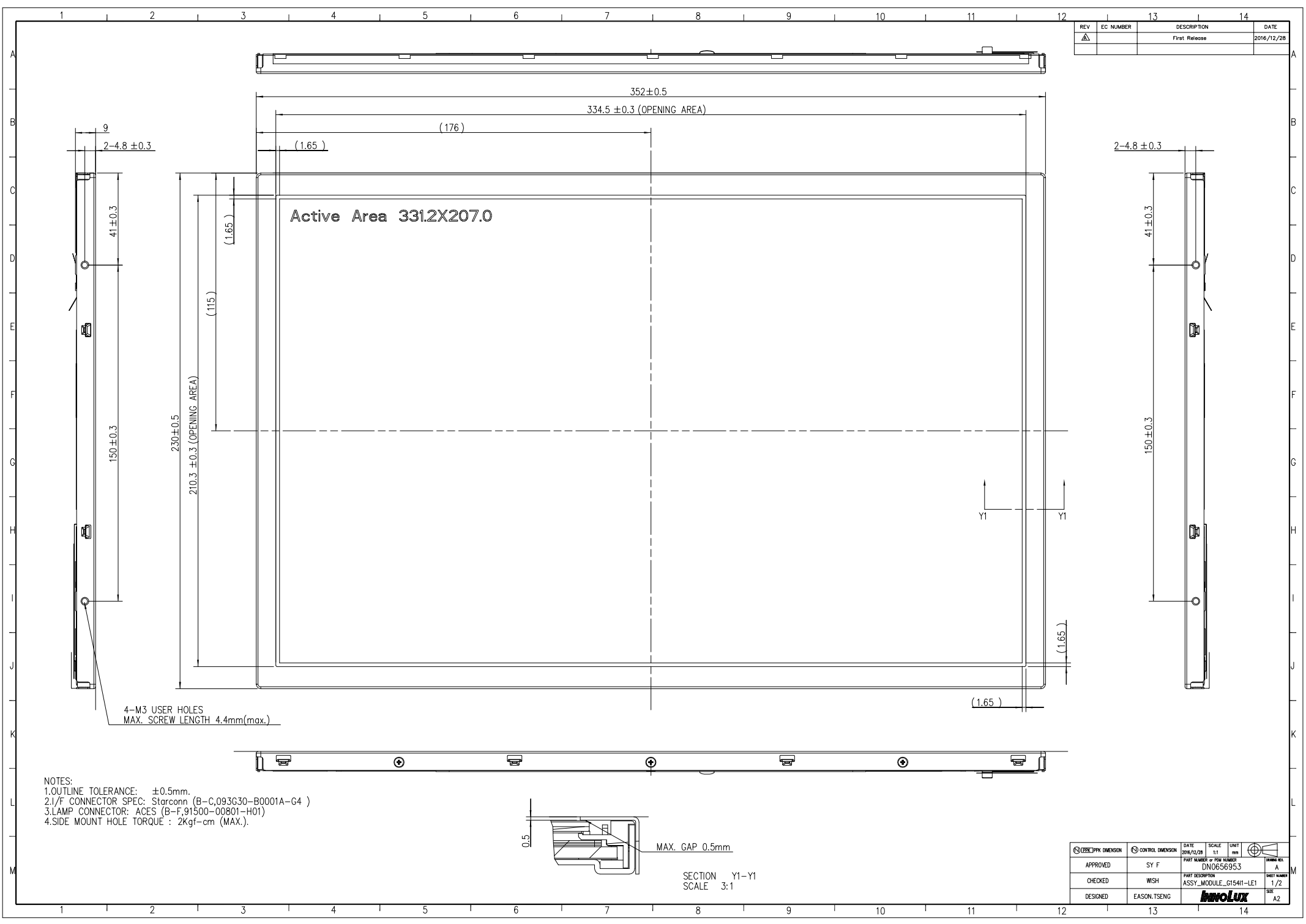

REV	EC NUMBER	DESCRIPTION	DATE
△		First Release	2016/12/28

Active Area 331.2X207.0

4-M3 USER HOLES  
MAX. SCREW LENGTH 4.4mm(max.)

- NOTES:  
 1. OUTLINE TOLERANCE: ±0.5mm.  
 2. I/F CONNECTOR SPEC: Starconn (B-C,093G30-B0001A-G4)  
 3. LAMP CONNECTOR: ACES (B-F,91500-00801-H01)  
 4. SIDE MOUNT HOLE TORQUE : 2kgf-cm (MAX.).

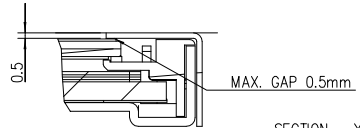

SECTION Y1-Y1  
SCALE 3:1

DISCIPK DIMENSION	CONTROL DIMENSION	DATE	SCALE	UNIT	FORM NO.
APPROVED	SY F	2016/12/28	E1	mm	A
CHECKED	WISH	PART NUMBER OR JOB NUMBER		DN0656953	SHEET NUMBER
DESIGNED	EASON.TSENG	PART DESCRIPTION		ASSY_MODULE_G15411-LE1	1/2

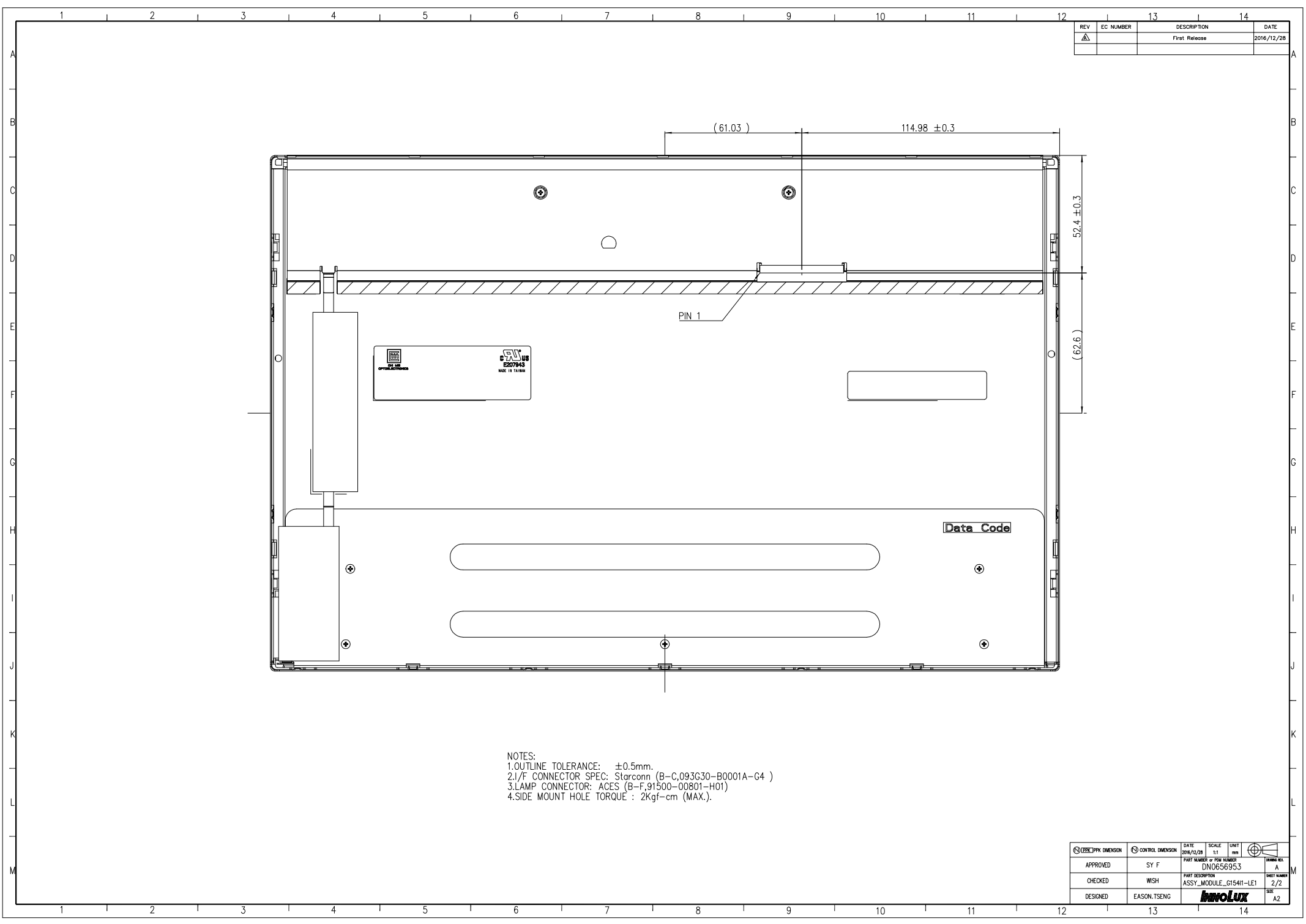

REV	EC NUMBER	DESCRIPTION	DATE
△		First Release	2016/12/28

NOTES:  
 1. OUTLINE TOLERANCE: ±0.5mm.  
 2. I/F CONNECTOR SPEC: Starconn (B-C,093G30-B0001A-G4 )  
 3. LAMP CONNECTOR: ACES (B-F,91500-00801-H01)  
 4. SIDE MOUNT HOLE TORQUE : 2Kgf-cm (MAX.).

DISCIPLIN DIMENSION	CONTROL DIMENSION	DATE	SCALE	UNIT	DRIVING IN
APPROVED	SY F	2016/12/28	1:1	mm	A
CHECKED	WISH	PART NUMBER OR JOB NUMBER		DN0656953	SHEET NUMBER
DESIGNED	EASON.TSENG	PART DESCRIPTION		ASSY_MODULE_G15411-LE1	2/2



Our company network supports you worldwide with offices in Germany, Austria, Switzerland, the UK and the USA. For more information please contact:

## Headquarters

### Germany



#### FORTEC Elektronik AG

Augsburger Str. 2b  
82110 Germering

Phone: +49 89 894450-0  
E-Mail: [info@forteca.de](mailto:info@forteca.de)  
Internet: [www.forteca.de](http://www.forteca.de)

## Fortec Group Members

### Austria



#### Distec GmbH Office Vienna

Nuschinggasse 12  
1230 Wien

Phone: +43 1 8673492-0  
E-Mail: [info@distec.de](mailto:info@distec.de)  
Internet: [www.distec.de](http://www.distec.de)

### Germany



#### Distec GmbH

Augsburger Str. 2b  
82110 Germering

Phone: +49 89 894363-0  
E-Mail: [info@distec.de](mailto:info@distec.de)  
Internet: [www.distec.de](http://www.distec.de)

### Switzerland



#### ALTRAC AG

Bahnhofstraße 3  
5436 Würenlos

Phone: +41 44 7446111  
E-Mail: [info@altrac.ch](mailto:info@altrac.ch)  
Internet: [www.altrac.ch](http://www.altrac.ch)

### United Kingdom



#### Display Technology Ltd.

Osprey House, 1 Osprey Court  
Hichingbrooke Business Park  
Huntingdon, Cambridgeshire, PE29 6FN

Phone: +44 1480 411600  
E-Mail: [info@displaytechnology.co.uk](mailto:info@displaytechnology.co.uk)  
Internet: [www.displaytechnology.co.uk](http://www.displaytechnology.co.uk)

### USA



#### Apollo Display Technologies, Corp.

87 Raynor Avenue,  
Unit 1 Ronkonkoma,  
NY 11779

Phone: +1 631 5804360  
E-Mail: [info@apolloDisplays.com](mailto:info@apolloDisplays.com)  
Internet: [www.apolloDisplays.com](http://www.apolloDisplays.com)