



OUR GLOBAL
COMPETENCE
CENTRES

 APOLLO DISPLAY
TECHNOLOGIES



 DISTEC



 DISPLAY
TECHNOLOGY



Datasheet

InnoLux

; %+\$>%@%

ÔPËËÍ J

Doc. Number :

- Tentative Specification
- Preliminary Specification
- Approval Specification

MODEL NO.: G170J1
SUFFIX: LE1

Customer:	
APPROVED BY	SIGNATURE
<u>Name / Title</u> _____	_____
Note	
<hr/> Please return 1 copy for your confirmation with your signature and comments.	

Approved By	Checked By	Prepared By
許君速 2018.10.01	林秋森 2018.10.01	王啟瑜 2018.10.01

CONTENTS

1. GENERAL DESCRIPTION	5
1.1 OVERVIEW	5
1.2 FEATURES.....	5
1.3 APPLICATION	5
1.4 GENERAL SPECIFICATIONS	5
1.5 MECHANICAL SPECIFICATIONS.....	5
2. ABSOLUTE MAXIMUM RATINGS	6
2.1 ABSOLUTE RATINGS OF ENVIRONMENT.....	6
2.2 ELECTRICAL ABSOLUTE RATINGS	7
2.2.1 TFT LCD MODULE	7
2.2.2 LED CONVERTER.....	7
3. ELECTRICAL CHARACTERISTICS	8
3.1 TFT LCD MODULE	8
3.2 LED CONVERTER	10
4. BLOCK DIAGRAM	12
4.1 TFT LCD MODULE.....	12
5. INTERFACE PIN ASSIGNMENT.....	13
5.1 TFT LCD MODULE.....	13
5.2 BACKLIGHT UNIT (Converter connector pin).....	14
5.3 COLOR DATA INPUT ASSIGNMENT	15
6. INTERFACE TIMING	16
6.1 INPUT SIGNAL TIMING SPECIFICATIONS	16
6.2 POWER ON/OFF SEQUENCE.....	18
6.3 The Input Data Format.....	19
7. OPTICAL CHARACTERISTICS	20
7.1 TEST CONDITIONS	20
7.2 OPTICAL SPECIFICATIONS.....	20
8. RELIABILITY TEST CRITERIA	23
9. packaging.....	24
9.1 PACKING SPECIFICATIONS	24
9.2 PACKING METHOD	24
9.3 UN-PACKING METHOD	25
10. DEFINITION OF LABELS.....	26
10.1 MODULE LABEL	26
10.2 OPTICAL LABEL	27

11. PRECAUTIONS	28
11.1 ASSEMBLY AND HANDLING PRECAUTIONS.....	28
11.2 SAFETY PRECAUTIONS	28
12. MECHANICAL CHARACTERIS	29

REVISION HISTORY

Version	Date	Page	Description
2.0	2012.03.22	All	Approval spec was first issued (Rev: C1)
2.1	2015.05.22	7	Modified Optical specification for Baseline structure
2.2	2015.06.08	3, 5, 6.1, 7	Modified Electrical Characteristics, Interface pin assignment, Input signal timing specification and Optical specification for EC2 structure
		10.2	Added Optical Label
	2015.08.24		Change from Rev: C1 to C2. PCBA components changed for EMI and noise reduction and LGP dimension changed.
2.3	2015.10.30	1.1	Updated 1.1 General Overview.
		1.4	Updated 1.4 Total power consumption (typ)
		2.1	Added 2.1 Note(1)(d)
		2.2.1	Modified max power supply voltage
		3.1	Removed Ripple voltage item Modified LVDS common voltage Removed Differential LVDS voltage and terminating resistor
		3.2	Updated LED Converter Power Consumption & PWM Control Duty Ratio
		5.2	Updated Backlight Unit(Converter connector pin order of client)
		6.1	Modified Input Signal Timing Specifications
		7.2	Updated Optical Specifications
		8	Updated Reliability Test Criteria
		12	Updated Mechanical drawings (Rear)
	2015.12.01		Change from Rev:C2 to C3 for implement the frame mura solution
2.4	2016.04.29	10.1	Remove Innolux logo from module label
2.5	2018.09.21	8	Updated reliability test criteria

1. GENERAL DESCRIPTION

1.1 OVERVIEW

G170J1- LE1 is a 17"IAV (Industrial/Amusement/Vehicle) TFT Liquid Crystal Display module with LED backlight unit and 30-pin-and-2ch LVDS interface. This product supports 1920 x 1200 WUXGA format and can display true 16.7M colors. The converter for LED backlight is built-in.

1.2 FEATURES

- Excellent brightness (600 nits)
- High color saturation sRGB
- WUXGA (1920 x 1200 pixels) resolution
- DE (Data Enable) only mode
- LVDS (Low Voltage Differential Signaling) interface
- Ultra wide viewing angle: 176(H)/ 176(V) (CR>10)
- Wide operation and storage temperature range

1.3 APPLICATION

- TFT LCD monitor for Industrial application

1.4 GENERAL SPECIFICATIONS

Item	Specification	Unit	Note
Active Area	365.76 (H) x 228.6 (V)	mm	(1)
Bezel Opening Area	369 (H) x 231.8 (V)	mm	
Driver Element	a-si TFT active matrix	-	-
Pixel Number	1920 x R.G.B. x 1200	pixel	-
Pixel Pitch	0.1905 (H) x 0.1905 (V)	mm	-
Pixel Arrangement	RGB vertical stripe	-	-
Display Colors	16.7 M	color	-
Display Operation Mode	Transmissive mode / Normally black	-	-
Surface Treatment	Anti-Glare, 3H	-	-
Total power consumption(typ)	29.25	W	typ

Note (1)Please refer to the attached drawings for more information of front and back outline dimensions.

1.5 MECHANICAL SPECIFICATIONS

Item	Min.	Typ.	Max.	Unit	Note	
Module Size	Horizontal (H)	386.2	386.8	387.4	mm	(1)
	Vertical (V)	250.2	250.8	251.4	mm	
	Depth (D)	18.25	18.6	18.95	mm	-
Weight	-	1675	1745	g	-	

Note (1)Please refer to the attached drawings for more information of front and back outline dimensions.

2. ABSOLUTE MAXIMUM RATINGS

2.1 ABSOLUTE RATINGS OF ENVIRONMENT

Item	Symbol	Value		Unit	Note
		Min.	Max.		
Operating Ambient Temperature	T _{OP}	-20	+80	°C	
Storage Temperature	T _{ST}	-40	+90	°C	

Note (1) Temperature and relative humidity range is shown in the figure below.

- (a) 90 %RH Max. ($T_a \leq 40$ °C).
- (b) Wet-bulb temperature should be 39 °C Max.
- (c) No condensation
- (d) The absolute maximum rating values of this product are not allowed to be exceeded at any times.
The module should not be used over the absolute maximum rating value. It will cause permanently unrecoverable function fail in such a condition.

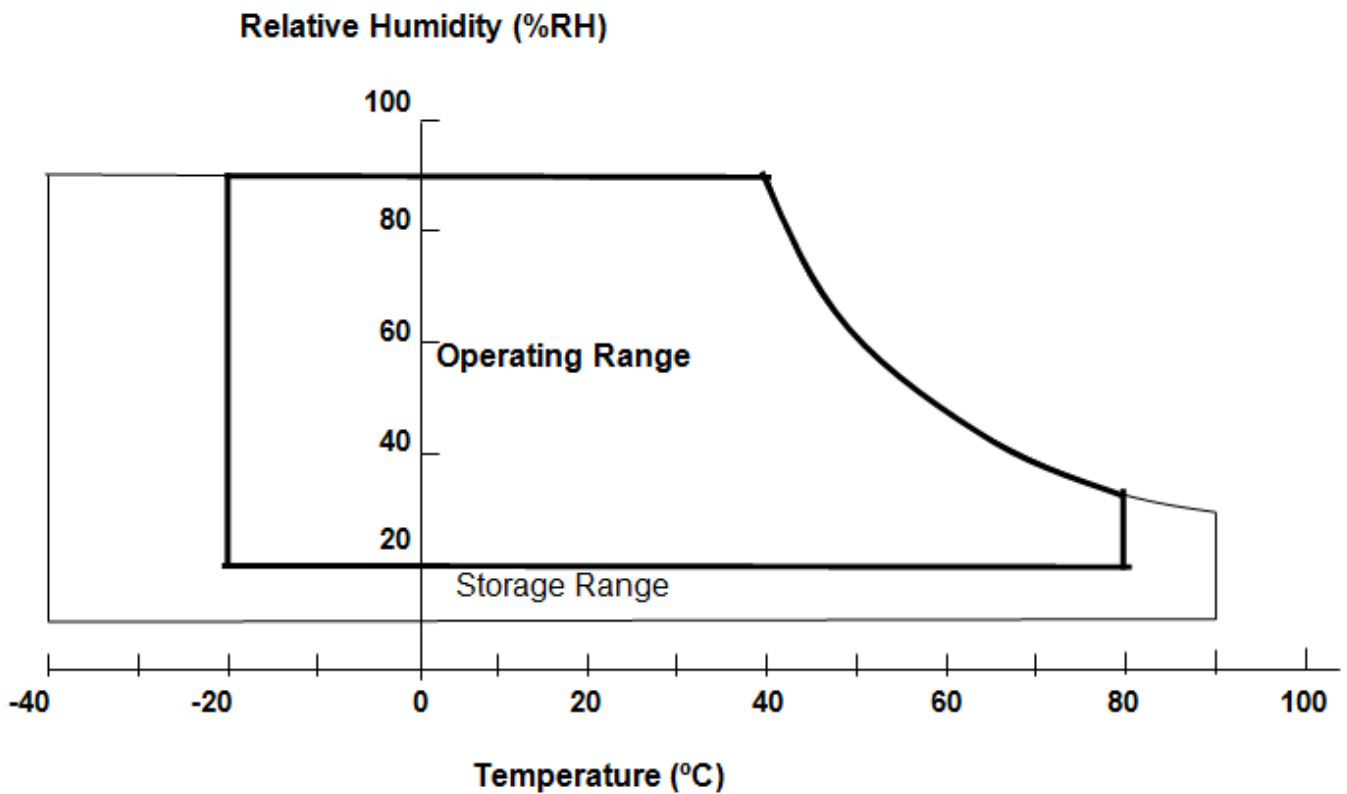

2.2 ELECTRICAL ABSOLUTE RATINGS

2.2.1 TFT LCD MODULE

Item	Symbol	Value		Unit	Note
		Min.	Max.		
Power Supply Voltage	VCC	-0.3	7	V	(1)

2.2.2 LED CONVERTER

Item	Symbol	Value		Unit	Note
		Min.	Max.		
Converter Voltage	V_i	-0.3	24	V	(1), (2)
Enable Voltage	EN	---	5.5	V	
Backlight Adjust	ADJ	---	5.5	V	

Note (1) Permanent damage to the device may occur if maximum values are exceeded. Function operation should be restricted to the conditions described under Normal Operating Conditions.

Note (2) Specified values are for LED light bar (Refer to 3.2 for further information).

3. ELECTRICAL CHARACTERISTICS

3.1 TFT LCD MODULE

Parameter	Symbol	Value			Unit	Note
		Min.	Typ.	Max.		
Power Supply Voltage	V_{CC}	4.5	5	5.5	V	(1)
Rush Current	I_{RUSH}	-	-	3.0	A	(2)
Power Supply Current	White	-	1050	1150	mA	(3)
	Black	-	550	650	mA	
	Vertical Stripe	-	880	1056	mA	
Power Consumption	P_L	-	5.25	5.75	W	
LVDS differential input voltage	V_{id}	100	-	600	mV	
LVDS common input voltage	V_{ic}	0.7	1.2	1.6	V	

Note (1) The assembly should be always operated within above ranges.

Note (2) Measurement Conditions:

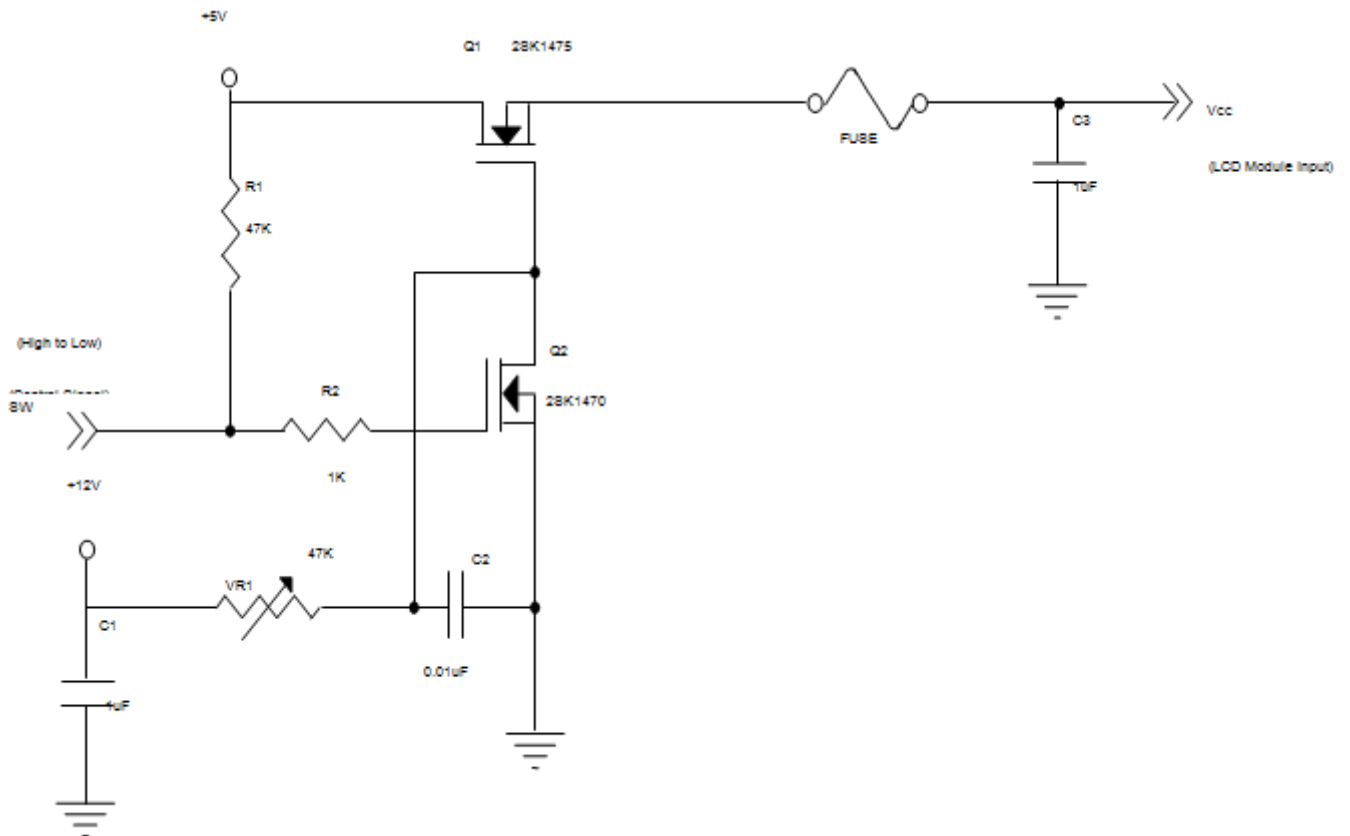

VCC rising time is 470us

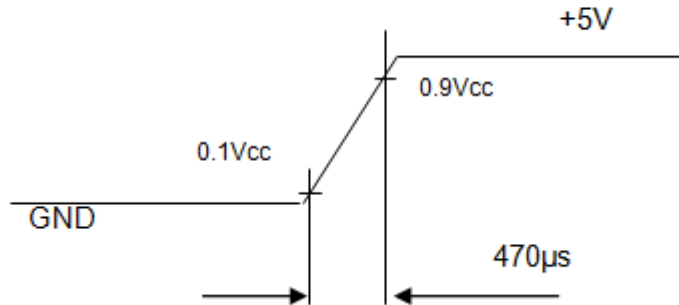

Note (3) The specified power supply current is under the conditions at $V_{cc} = 5\text{ V}$, $T_a = 25 \pm 2\text{ }^\circ\text{C}$, $f_v = 60\text{ Hz}$, whereas a power dissipation check pattern below is displayed.

a. White Pattern



Active Area

b. Black Pattern



Active Area

c. Vertical Stripe Pattern

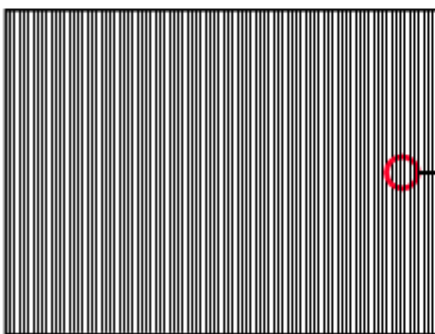

Active Area

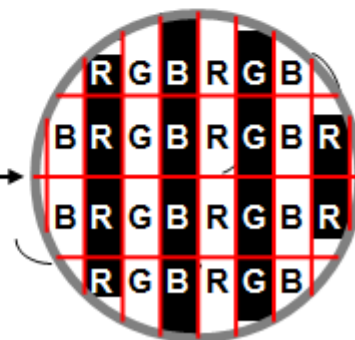

3.2 LED CONVERTER

Parameter	Symbol	Value			Unit	Note
		Min.	Typ.	Max.		
Converter Power Supply Voltage	V_i	9	12.0	16	V	(Duty 100%)
Converter Power Supply Current	I_i	1.0	2.0	3.0	A	@ $V_i = 12V$ (Duty 100%)
LED Converter Power Consumption	P_i	16	24	27	W	@ $V_i = 12V$ (Duty 100%)
EN Control Level	Backlight on	2.0	---	5.0	V	
	Backlight off	0	---	0.8	V	
PWM Control Level	PWM High Level	2.0	---	5.0	V	
	PWM Low Level	0	---	0.15	V	
PWM Control Duty Ratio		1		100	%	
PWM Control Frequency	f_{PWM}	190	200	210	Hz	
LED Life Time	L_L	30,000			Hrs	(2)

Note (1) LED current is measured by utilizing a high frequency current meter as shown below:

Note (2) The lifetime of LED is defined as the time when it continues to operate under the conditions at $T_a = 25 \pm 2 \text{ }^\circ\text{C}$ and $I_{LED} = 40\text{mA}_{DC}$ (LED forward current) until the **brightness becomes $\leq 50\%$** of its original value.

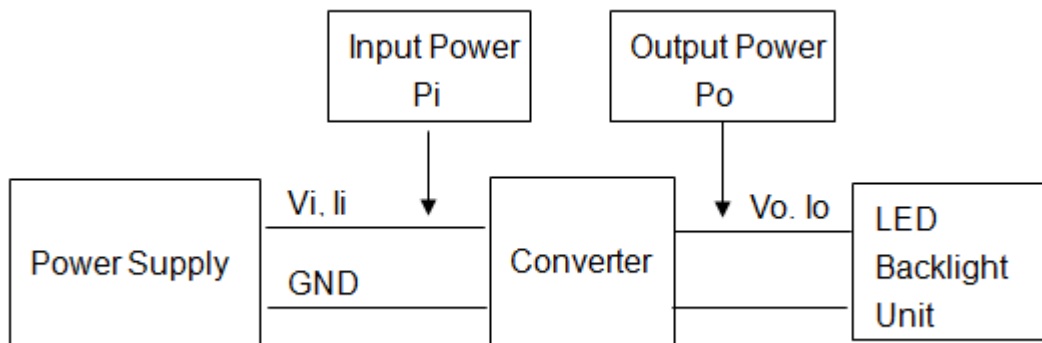

LED BL Block Diagram

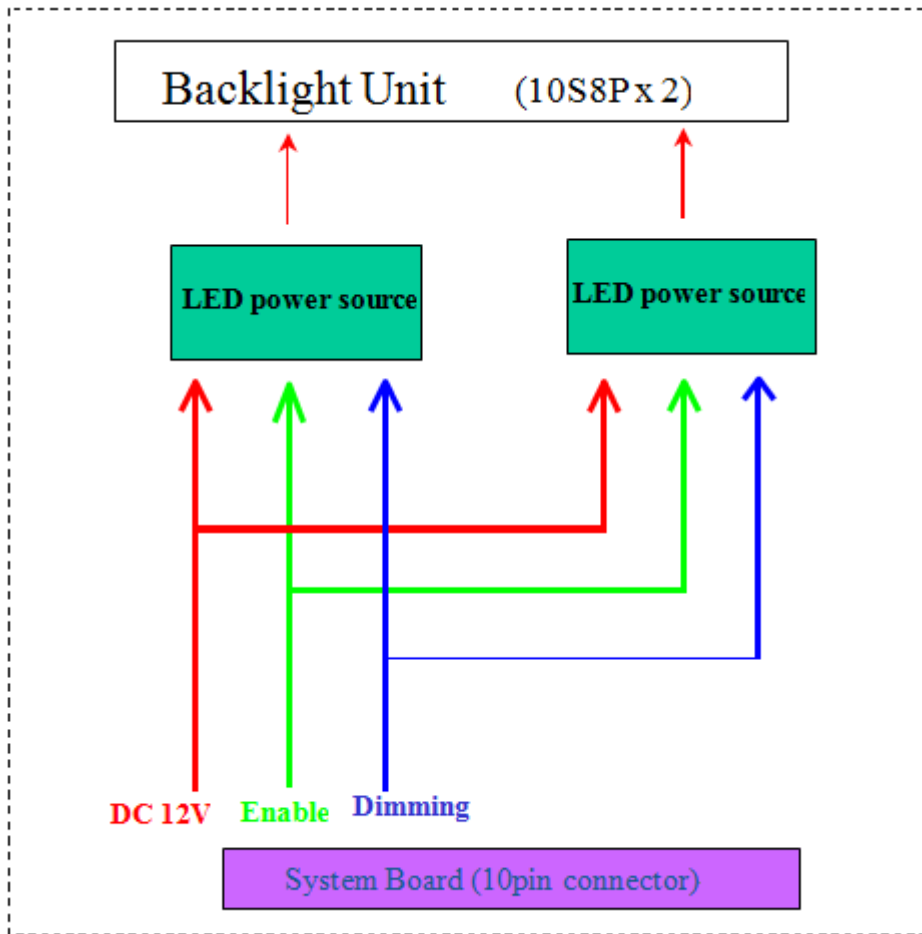

4. BLOCK DIAGRAM

4.1 TFT LCD MODULE

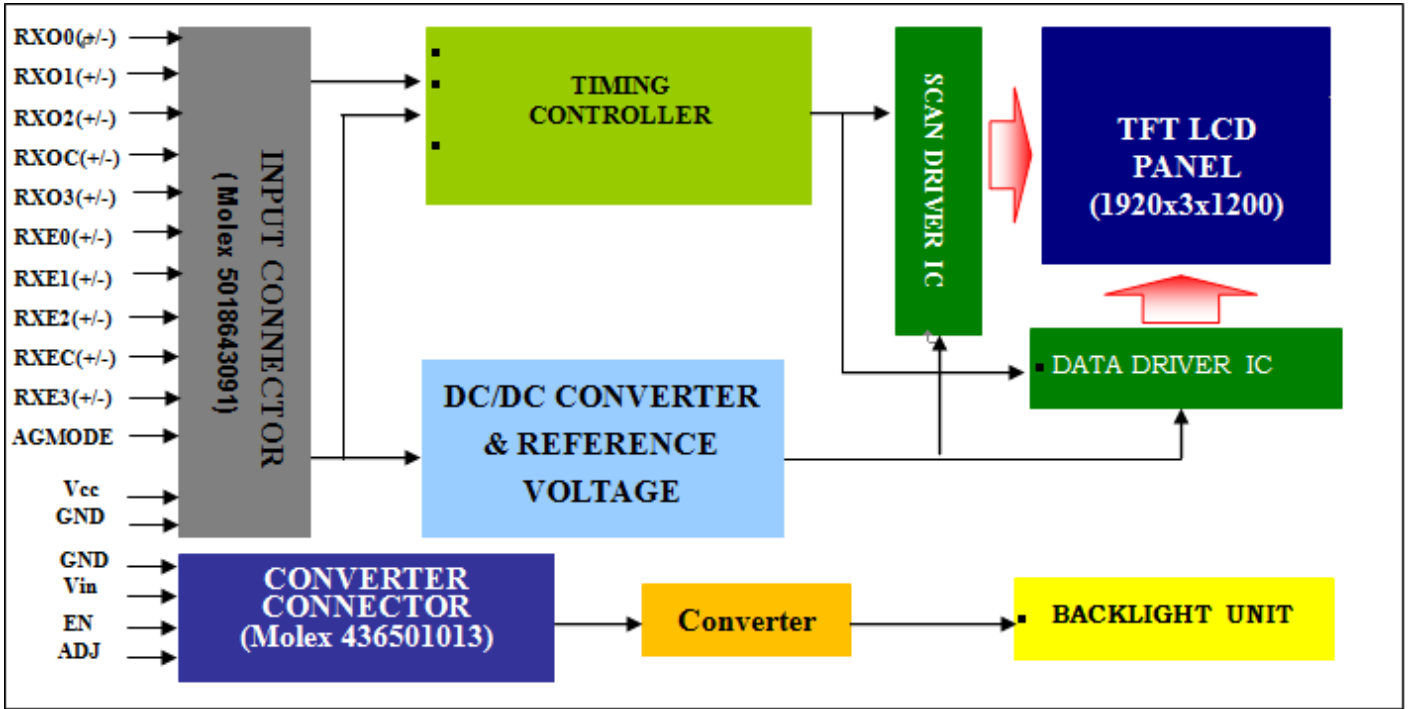

5. INTERFACE PIN ASSIGNMENT

5.1 TFT LCD MODULE

Pin No.	Symbol	Description	Note
1	RX00-	-LVDS differential data input, Chan 0-Odd	-
2	RX00+	+LVDS differential data input, Chan 0-Odd	-
3	RX01-	-LVDS differential data input, Chan 1-Odd	-
4	RX01+	+LVDS differential data input, Chan 1-Odd	-
5	RX02-	-LVDS differential data input, Chan 2-Odd	-
6	RX02+	+LVDS differential data input, Chan 2-Odd	-
7	VSS	Ground	
8	RXOC-	-LVDS differential Clock input (Odd)	
9	RXOC+	+LVDS differential Clock input (Odd)	
10	RX03-	-LVDS differential data input, Chan 3-Odd	
11	RX03+	+LVDS differential data input, Chan 3-Odd	
12	RXE0-	-LVDS differential data input, Chan 0-Even	-
13	RXE0+	+LVDS differential data input, Chan 0-Even	-
14	VSS	Ground	-
15	RXE1-	-LVDS differential data input, Chan 1-Even	-
16	RXE1+	+LVDS differential data input, Chan 1-Even	-
17	VSS	Ground	-
18	RXE2-	-LVDS differential data input, Chan 2-Even	-
19	RXE2+	+LVDS differential data input, Chan 2-Even	-
20	RXEC-	-LVDS differential Clock input (Even)	-
21	RXEC+	+LVDS differential Clock input (Even)	-
22	RXE3-	-LVDS differential data input, Chan 3-Even	-
23	RXE3+	+LVDS differential data input, Chan 3-Even	-
24	VSS	Ground	-
25	VSS	Ground	-
26	NC	No Connection	-
27	AGMODE	Aging mode selection (Default connection GND) High (3.3V), Aging mode. Low (0V), Normal display.	-
28	Vcc	+5.0V power supply	-
29	Vcc	+5.0V power supply	-
30	Vcc	+5.0V power supply	-

Note (1) Connector Part No.: MOLEX (5018643091)

5.2 BACKLIGHT UNIT (Converter connector pin)

Opposite side for Client (connector type: MOLEX 43640)

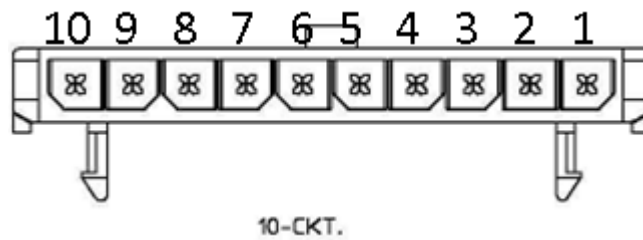

Pin	Symbol	Description	Remark
10	V_i	Converter input voltage	12V
9	V_i	Converter input voltage	12V
8	V_i	Converter input voltage	12V
7	V_{GND}	Converter ground	Ground
6	V_{GND}	Converter ground	Ground
5	V_{GND}	Converter ground	Ground
4	EN	Enable pin	3.3V
3	NA	NA	NA
2	ADJ	PWM adjust	PWM Dimming
1	NA	NA	NA

For LED Converter side (connector type: MOLEX 436501013)

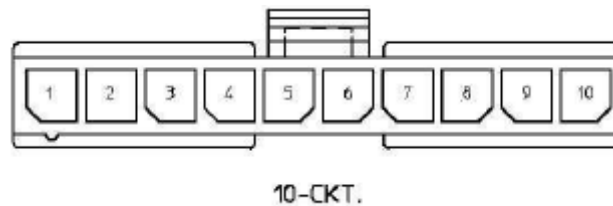

Pin	Symbol	Description	Remark
1	V_i	Converter input voltage	12V
2	V_i	Converter input voltage	12V
3	V_i	Converter input voltage	12V
4	V_{GND}	Converter ground	Ground
5	V_{GND}	Converter ground	Ground
6	V_{GND}	Converter ground	Ground
7	EN	Enable pin	3.3V
8	NA	NA	NA
9	ADJ	PWM adjust	PWM Dimming
10	NA	NA	NA

5.3 COLOR DATA INPUT ASSIGNMENT

The brightness of each primary color (red, green and blue) is based on the 8-bit gray scale data input for the color. The higher the binary input, the brighter the color. The table below provides the assignment of color versus data input.

Color		Data Signal																						
		Red								Green								Blue						
		R7	R6	R5	R4	R3	R2	R1	R0	G7	G6	G5	G4	G3	G2	G1	G0	B7	B6	B5	B4	B3	B2	B1
Basic Colors	Black	0	0	0	0	0	0	0	0	0	0	0	0	0	0	0	0	0	0	0	0	0	0	0
	Red	1	1	1	1	1	1	1	1	0	0	0	0	0	0	0	0	0	0	0	0	0	0	0
	Green	0	0	0	0	0	0	0	0	1	1	1	1	1	1	1	0	0	0	0	0	0	0	0
	Blue	0	0	0	0	0	0	0	0	0	0	0	0	0	0	0	1	1	1	1	1	1	1	1
	Cyan	0	0	0	0	0	0	0	0	1	1	1	1	1	1	1	1	1	1	1	1	1	1	1
	Magenta	1	1	1	1	1	1	1	1	0	0	0	0	0	0	0	1	1	1	1	1	1	1	1
	Yellow	1	1	1	1	1	1	1	1	1	1	1	1	1	1	1	0	0	0	0	0	0	0	0
	White	1	1	1	1	1	1	1	1	1	1	1	1	1	1	1	1	1	1	1	1	1	1	1
Gray Scale Of Red	Red(0) / Dark	0	0	0	0	0	0	0	0	0	0	0	0	0	0	0	0	0	0	0	0	0	0	
	Red(1)	0	0	0	0	0	0	1	0	0	0	0	0	0	0	0	0	0	0	0	0	0	0	
	Red(2)	0	0	0	0	0	1	0	0	0	0	0	0	0	0	0	0	0	0	0	0	0	0	
	⋮	⋮	⋮	⋮	⋮	⋮	⋮	⋮	⋮	⋮	⋮	⋮	⋮	⋮	⋮	⋮	⋮	⋮	⋮	⋮	⋮	⋮	⋮	
	⋮	⋮	⋮	⋮	⋮	⋮	⋮	⋮	⋮	⋮	⋮	⋮	⋮	⋮	⋮	⋮	⋮	⋮	⋮	⋮	⋮	⋮	⋮	
	Red(253)	1	1	1	1	1	1	0	1	0	0	0	0	0	0	0	0	0	0	0	0	0	0	
	Red(254)	1	1	1	1	1	1	1	0	0	0	0	0	0	0	0	0	0	0	0	0	0	0	
	Red(255)	1	1	1	1	1	1	1	1	0	0	0	0	0	0	0	0	0	0	0	0	0	0	
Gray Scale Of Green	Green(0) / Dark	0	0	0	0	0	0	0	0	0	0	0	0	0	0	0	0	0	0	0	0	0	0	
	Green(1)	0	0	0	0	0	0	0	0	0	0	0	0	0	1	0	0	0	0	0	0	0	0	
	Green(2)	0	0	0	0	0	0	0	0	0	0	0	0	1	0	0	0	0	0	0	0	0	0	
	⋮	⋮	⋮	⋮	⋮	⋮	⋮	⋮	⋮	⋮	⋮	⋮	⋮	⋮	⋮	⋮	⋮	⋮	⋮	⋮	⋮	⋮	⋮	
	⋮	⋮	⋮	⋮	⋮	⋮	⋮	⋮	⋮	⋮	⋮	⋮	⋮	⋮	⋮	⋮	⋮	⋮	⋮	⋮	⋮	⋮	⋮	
	Green(253)	0	0	0	0	0	0	0	1	1	1	1	1	1	0	1	0	0	0	0	0	0	0	
	Green(254)	0	0	0	0	0	0	0	1	1	1	1	1	1	1	0	0	0	0	0	0	0	0	
	Green(255)	0	0	0	0	0	0	0	1	1	1	1	1	1	1	1	0	0	0	0	0	0	0	
Gray Scale Of Blue	Blue(0) / Dark	0	0	0	0	0	0	0	0	0	0	0	0	0	0	0	0	0	0	0	0	0	0	
	Blue(1)	0	0	0	0	0	0	0	0	0	0	0	0	0	0	0	0	0	0	0	0	0	1	
	Blue(2)	0	0	0	0	0	0	0	0	0	0	0	0	0	0	0	0	0	0	0	0	1	0	
	⋮	⋮	⋮	⋮	⋮	⋮	⋮	⋮	⋮	⋮	⋮	⋮	⋮	⋮	⋮	⋮	⋮	⋮	⋮	⋮	⋮	⋮	⋮	
	⋮	⋮	⋮	⋮	⋮	⋮	⋮	⋮	⋮	⋮	⋮	⋮	⋮	⋮	⋮	⋮	⋮	⋮	⋮	⋮	⋮	⋮	⋮	
	Blue(253)	0	0	0	0	0	0	0	0	0	0	0	0	0	0	1	1	1	1	1	1	1	0	
	Blue(254)	0	0	0	0	0	0	0	0	0	0	0	0	0	0	1	1	1	1	1	1	1	0	
	Blue(255)	0	0	0	0	0	0	0	0	0	0	0	0	0	0	1	1	1	1	1	1	1	1	

Note (1) 0: Low Level Voltage, 1: High Level Voltage

6. INTERFACE TIMING

6.1 INPUT SIGNAL TIMING SPECIFICATIONS

The input signal timing specifications are shown as the following table and timing diagram.

Signal	Item	Symbol	Min.	Typ.	Max.	Unit	Note
LVDS Clock	Frequency	F _c	66.11	77.06	79.63	MHz	-
	Period	T _c	-	12.97	-	ns	-
	Input Clock to data skew	TLVCCS	-0.02*T _c	-	0.02*T _c	ns	(2)
	Spread spectrum modulation range	F _{clkin_mod}	-	-	400	MHz	(3)
	Spread spectrum modulation frequency	F _{SSM}	-	-	200	KHz	
Vertical Display Term	Frame Rate	Fr	55	60	65	Hz	T _v =T _{vd} +T _{vb}
	Total	T _v	1202	1235	1245	Th	-
	Active Display	T _{vd}	1200	1200	1200	Th	-
	Blank	T _{vb}	T _v -T _{vd}	35	T _v -T _{vd}	Th	-
Horizontal Display Term	Total	T _h	1000	1040	1060	T _c	T _h =T _{hd} +T _{hb}
	Active Display	T _{hd}	960	960	960	T _c	-
	Blank	T _{hb}	T _h -T _{hd}	80	T _h -T _{hd}	T _c	-

Note (1) Since this assembly is operated in DE only mode, Hsync and Vsync input signals should be set to low logic level. Otherwise, this assembly would operate abnormally.

INPUT SIGNAL TIMING DIAGRAM

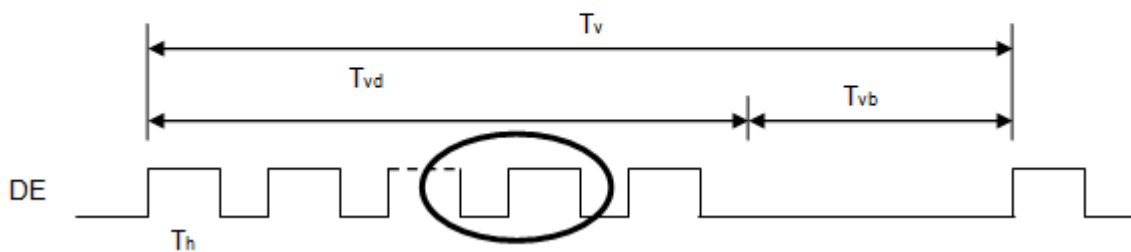

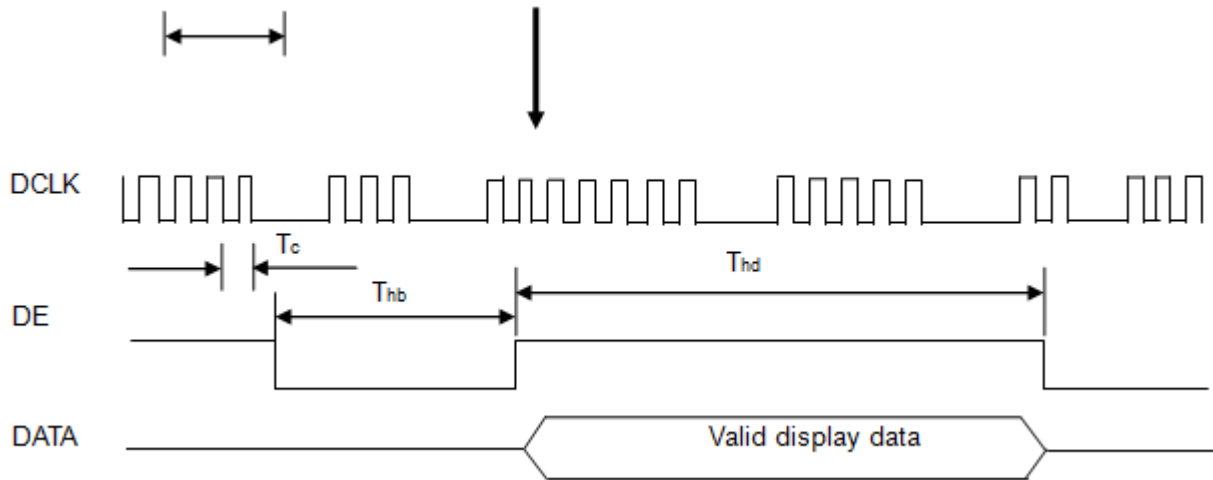

Note (2) Input Clock to data skew is defined as below figures .

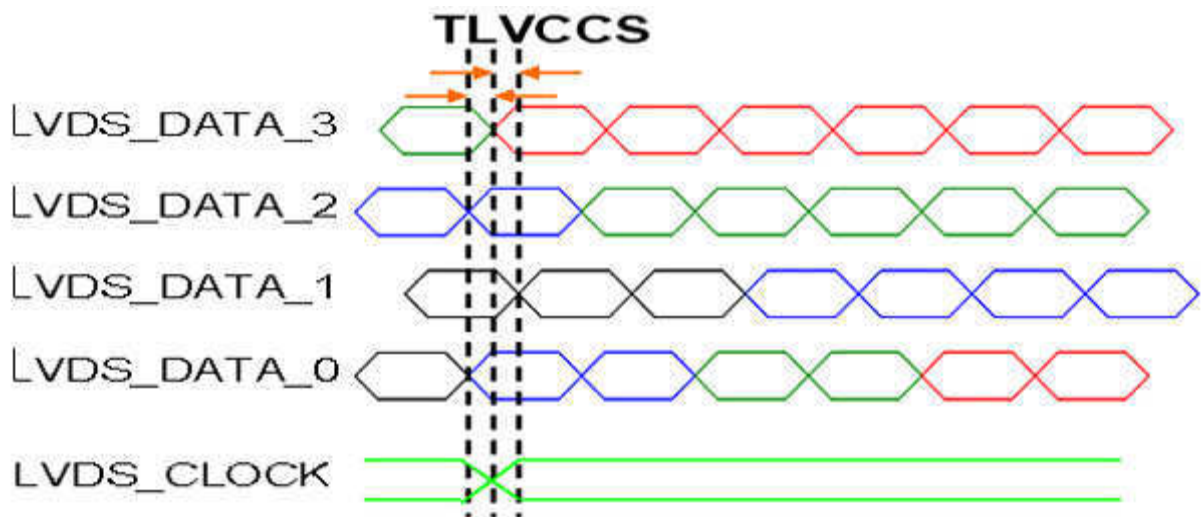

Note (3) The SSCG (Spread spectrum clock generator) is defined as below figures.

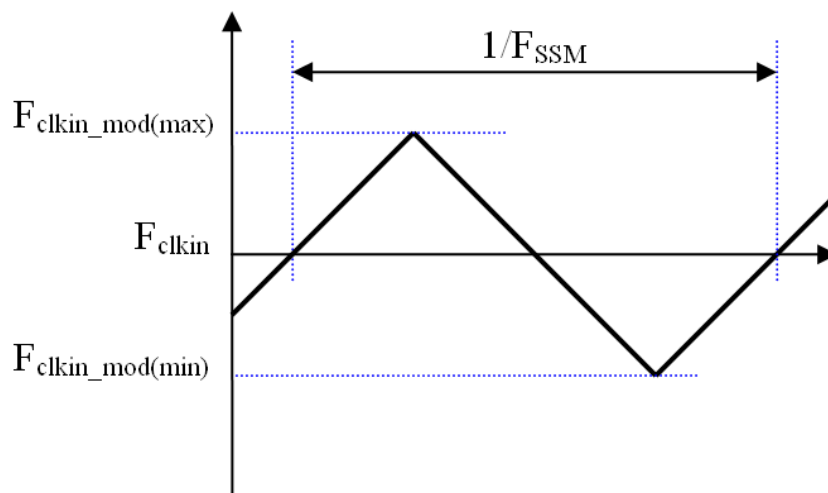

6.2 POWER ON/OFF SEQUENCE

To prevent a latch-up or DC operation of LCD assembly, the power on/off sequence should be as the diagram below.

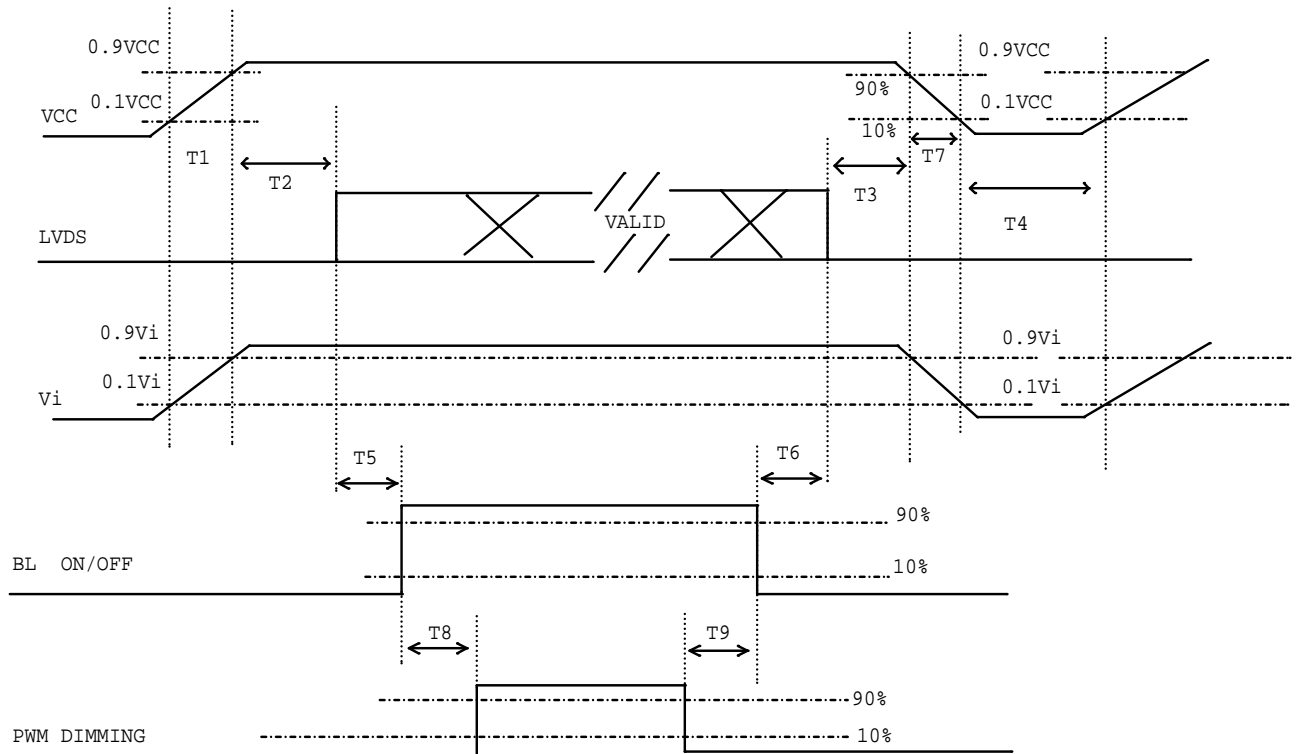

Power ON/OFF sequence

Note (1) Please avoid floating state of interface signal at invalid period.

Note (2) When the interface signal is invalid, be sure to pull down the power supply of LCD VCC to 0 V.

Note (3) The Backlight converter power must be turned on after the power supply for the logic and the interface signal is valid. The Backlight converter power must be turned off before the power supply for the logic and the interface signal is invalid.

Parameter	Value			Units
	Min	Typ	Max	
T1	0.5	-	10	ms
T2	0	-	50	ms
T3	0	-	50	ms
T4	500	-	-	ms
T5	200	-	-	ms
T6	200	-	-	ms
T7	5	-	100	ms
T8	10	-	-	ms
T9	10	-	-	Ms

6.3 The Input Data Format

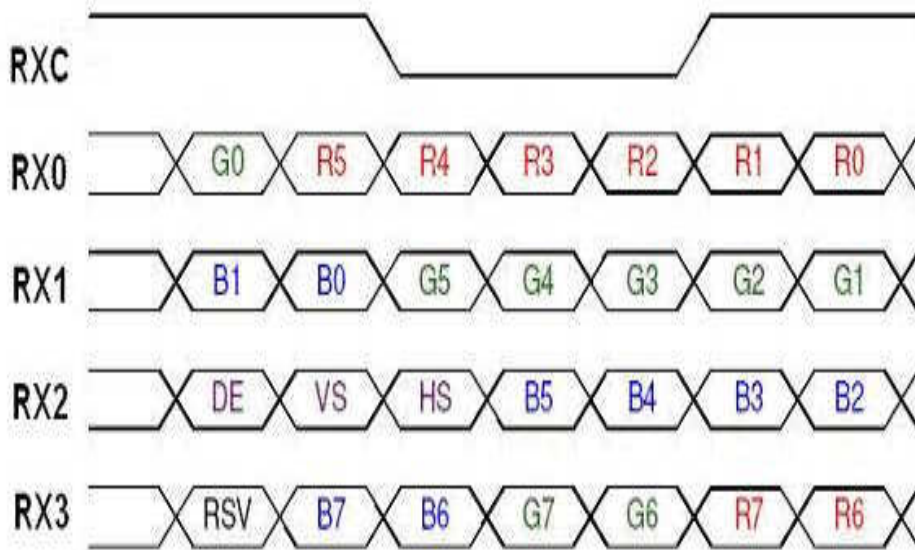

Note (1) R/G/B data 7: MSB, R/G/B data 0: LSB

Note (2) Please follow PSWG

Signal Name	Description	Remark
R7	Red Data 7 (MSB)	Red-pixel Data Each red pixel's brightness data consists of these 8 bits pixel data.
R6	Red Data 6	
R5	Red Data 5	
R4	Red Data 4	
R3	Red Data 3	
R2	Red Data 2	
R1	Red Data 1	
R0	Red Data 0 (LSB)	
G7	Green Data 7 (MSB)	Green-pixel Data Each green pixel's brightness data consists of these 8 bits pixel data.
G6	GreenData 6	
G5	GreenData 5	
G4	GreenData 4	
G3	GreenData 3	
G2	GreenData 2	
G1	GreenData 1	
G0	GreenData 0 (LSB)	
B7	Blue Data 7 (MSB)	Blue-pixel Data Each blue pixel's brightness data consists of these 8 bits pixel data.
B6	Blue Data 6	
B5	Blue Data 5	
B4	Blue Data 4	
B3	Blue Data 3	
B2	Blue Data 2	
B1	Blue Data 1	
B0	Blue Data 0 (LSB)	
RXCLKIN+ RXCLKIN-	LVDS Clock Input	
DE	Display Enable	
VS	Vertical Sync	
HS	Horizontal Sync	

Note (3) Output signals from any system shall be low or Hi-Z state when VCC is off

7. OPTICAL CHARACTERISTICS

7.1 TEST CONDITIONS

Item	Symbol	Value	Unit
Ambient Temperature	Ta	25±2	oC
Ambient Humidity	Ha	50±10	%RH
Supply Voltage	VCC	5	V
Input Signal	According to typical value in "3. ELECTRICAL CHARACTERISTICS"		
Converter Current	I _L	40±4mA	mA

7.2 OPTICAL SPECIFICATIONS

The relative measurement methods of optical characteristics are shown in 7.2. The following items should be measured under the test conditions described in 7.1 and stable environment shown in Note (6).

Item	Symbol	Condition	Min.	Typ.	Max.	Unit	Note	
Contrast Ratio	CR	$\theta_x=0^\circ, \theta_y=0^\circ$	1500	2000		-	(2)	
Response Time	TR		-	20	25	ms	(3)	
				9	15			
Center Luminance of White	LC		500	600	-	cd/m	(4)	
White Variation	δW		-		1.25	-	(6)	
Chromaticity	Red	Rx	Typ. -0.025	0.628	Typ. +0.025	-	(5)	
		Ry		0.311		-		
	Green	Gx		0.292		-		
		Gy		0.659		-		
	Blue	Bx		0.143		-		
		By		0.063		-		
	White	Wx		0.299		-		
		Wy		0.315		-		
Viewing Angle	Horizontal	θ_{x+}	CR≥10	80	88	-	Deg.	(1)
		θ_{x-}		80	88	-		
	Vertical	θ_{y+}		80	88	-		
		θ_{y-}		80	88	-		
Gamma	γ	9 Step Log gamma	2.25	2.35	2.45		Gamma	

The chromaticity of WRGB and luminance of white were calibrated with customer.

The calibration factors are listed below.

Calibration Factors	Lv (by multiplication)	Cx (by addition)	Cy (by addition)
W	0.942	0.000	0.000
R	-	0.007	-0.007
G	-	-0.010	0.015
B	-	-0.004	-0.003

Note (1) Definition of Viewing Angle (θ_x, θ_y):

Viewing angles are measured by BM5A

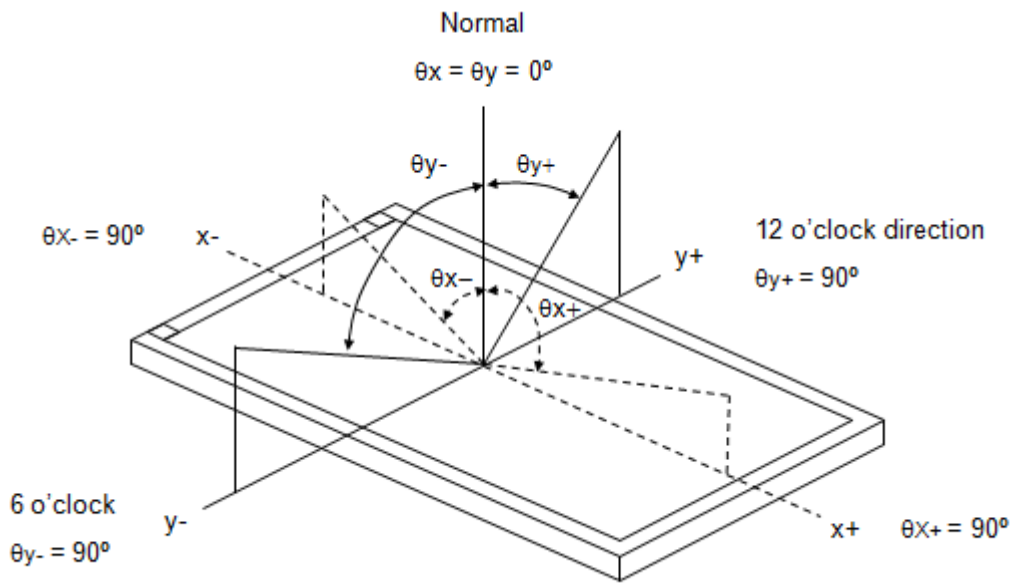

Note (2) Definition of Contrast Ratio (CR):

The contrast ratio can be calculated by the following expression.

$$\text{Contrast Ratio (CR)} = L_{255} / L_0$$

L255: Luminance of gray level 255

L 0: Luminance of gray level 0

CR = CR (5), where CR (X) is corresponding to the Contrast Ratio of the point X at the figure in Note (7).

Note (3) Definition of Response Time (T_R , T_F):

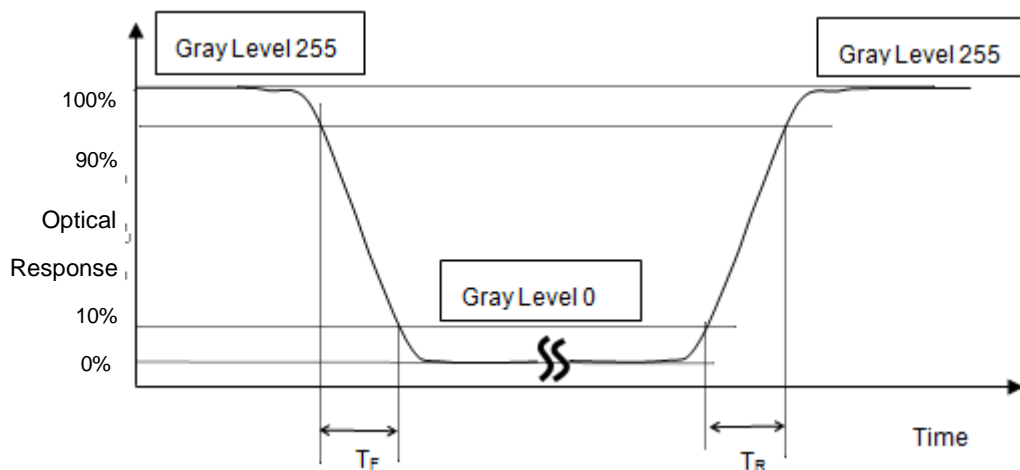

Note (4) Definition of Luminance of White (L_C):

Measure the luminance of gray level 255 at center point and 9 points

$L_C = L (5)$, where L (X) is corresponding to the luminance of the point X at the figure in Note (7).

Note (5) Measurement Setup:

The LCD assembly should be stabilized at given temperature for 30 minutes to avoid abrupt temperature change during measuring. In order to stabilize the luminance, the measurement should be executed after lighting Backlight for 30 minutes in a windless room.

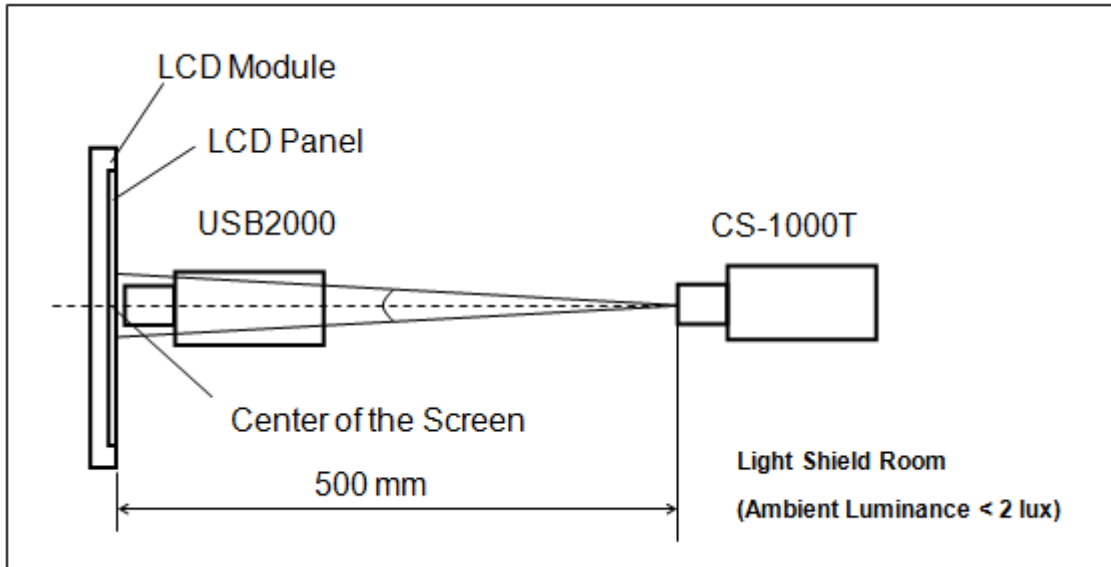

Note (6) Definition of White Variation (δW):

Measure the luminance of gray level 255 at 9 points

$$\delta W = \text{Maximum [L (1), L (2), L (3), L (4), L (5), L (6), L (7), L (8), L (9)]} / \text{Minimum [L (1), L (2), L (3), L (4), L (5), L (6), L (7), L (8), L (9)]}$$

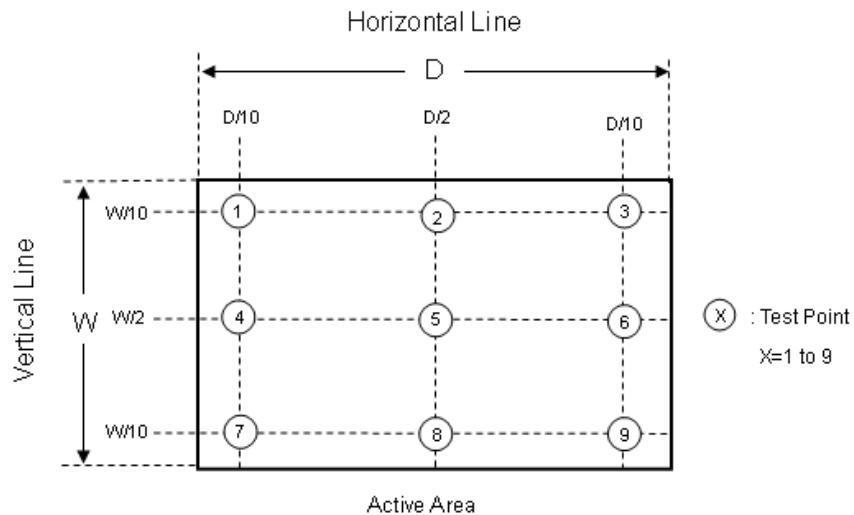

8. RELIABILITY TEST CRITERIA

Test Item	Test Condition	Note
High Temperature Storage Test	90°C, 500 hours	(1)
Low Temperature Storage Test	-40°C, 500 hours	(2)
Thermal Shock Storage Test (Non-Operating)	[(-40°C,30min)→(85°C,30min)]/cycle, 160hrs	(4)
High Temperature Operation Test	80°C, 600 hours	(1)
Low Temperature Operation Test	-20°C, 120 hours	(2)
High Temperature & High Humidity Operation Test	60°C, 90%RH, 500 hours	(4)
Shock (Non-Operating)	50G, 11ms, half sine wave, 3 times for each direction ± X, ± Y, ± Z.	(3)(4)
Vibration (Non-Operating)	Frequency: 10 ~55~10Hz;Sweep Mode: Log Sweep Sweep time: 1Oct/min;Acceleration: 1.5G;Test time:2 hr for each direction of X, Y, Z.	(3)(4)
ESD-Contact Mode Discharge	150pf, 330Ω, ±8KV	
ESD-Air Mode Discharge (old LGP, new PCBA)	150pf, 330Ω, ±15KV	

Note (1) There should be no condensation on the surface of panel during test.

Note (2) Temperature of panel display surface area should be 80 °C Max.

Note (3) At testing Vibration and Shock, the fixture in holding the module has to be hard and rigid enough so that the module would not be twisted or bent by the fixture.

Note (4) In the standard conditions, there is no function failure issue occurred. All the cosmetic specification is judged before the reliability test.

9. packaging

9.1 PACKING SPECIFICATIONS

- (1) 8pcs LCD modules / 1 Box
- (2) Box dimensions: 615 (L) X 515 (W) X 320 (H) mm
- (3) Weight: approximately 21.1Kg (8 modules per box)

9.2 PACKING METHOD

(1) Carton Packing should have no failure in the following reliability test items.

Test Item	Test Conditions	Note
Vibration	ISTA STANDARD Random, Frequency Range: 2 – 200 Hz Top & Bottom: 30 minutes (+Z), 10 min (-Z), Right & Left: 10 minutes (X) Back & Forth 10 minutes (Y)	Non Operation
Dropping Test	1 Angle, 3 Edge, 6 Face, 46 cm	Non Operation

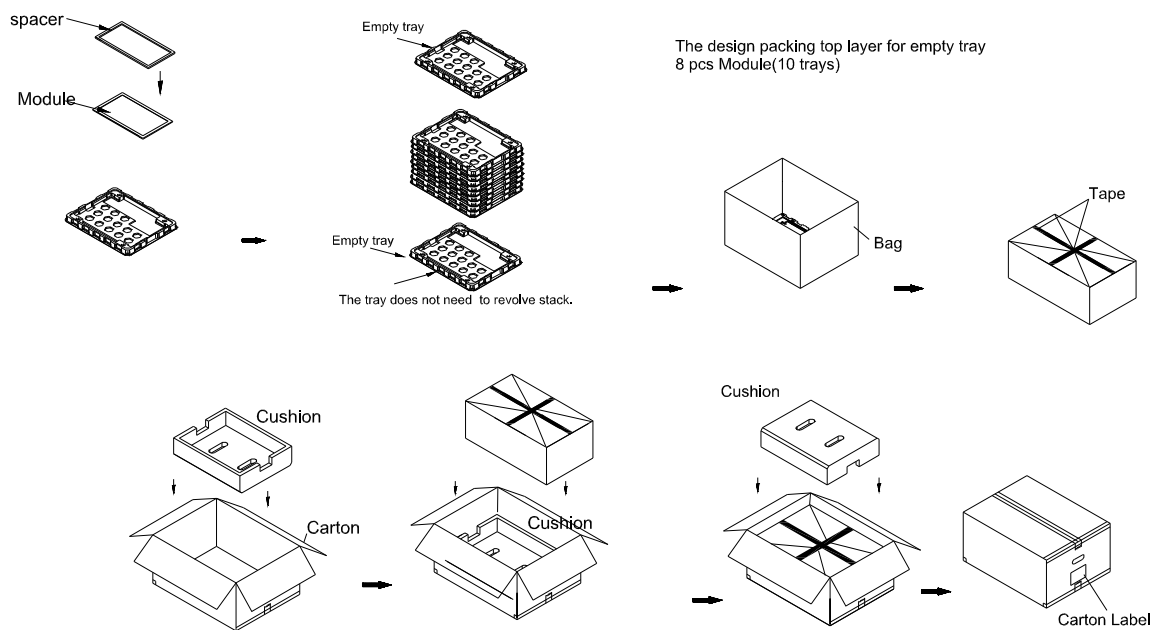

- (1) Carton dimensions : 615(L)x515(W)x320(H)mm
- (2) 8 modules/Carton

Figure. 9-1 Packing method

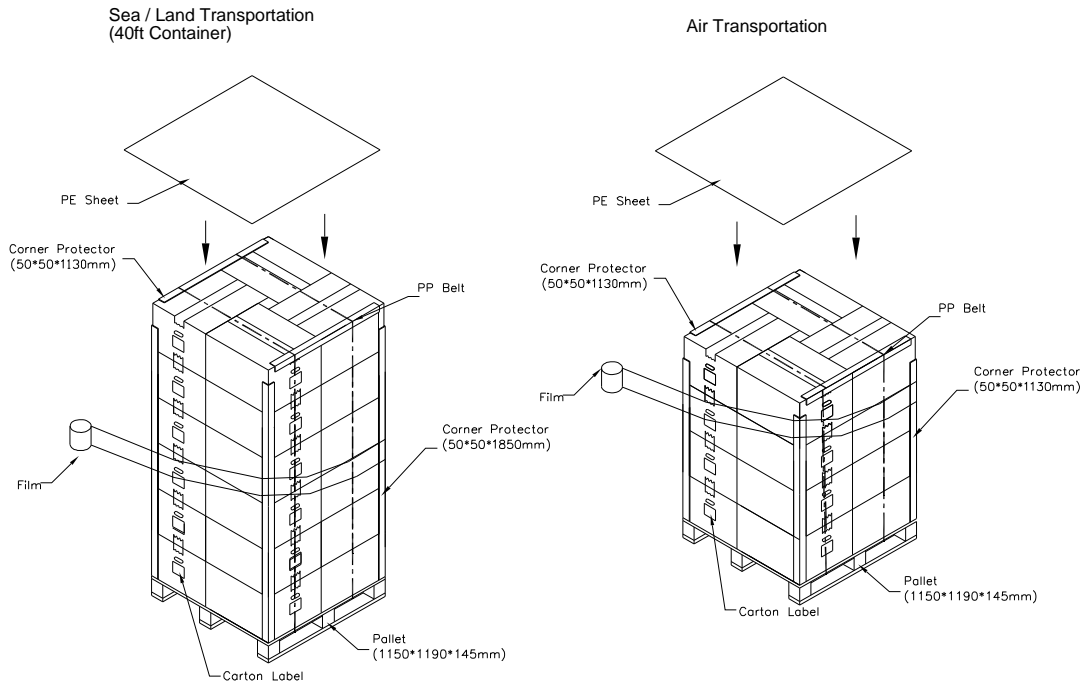

Figure. 9-2 Packing method

9.3 UN-PACKING METHOD

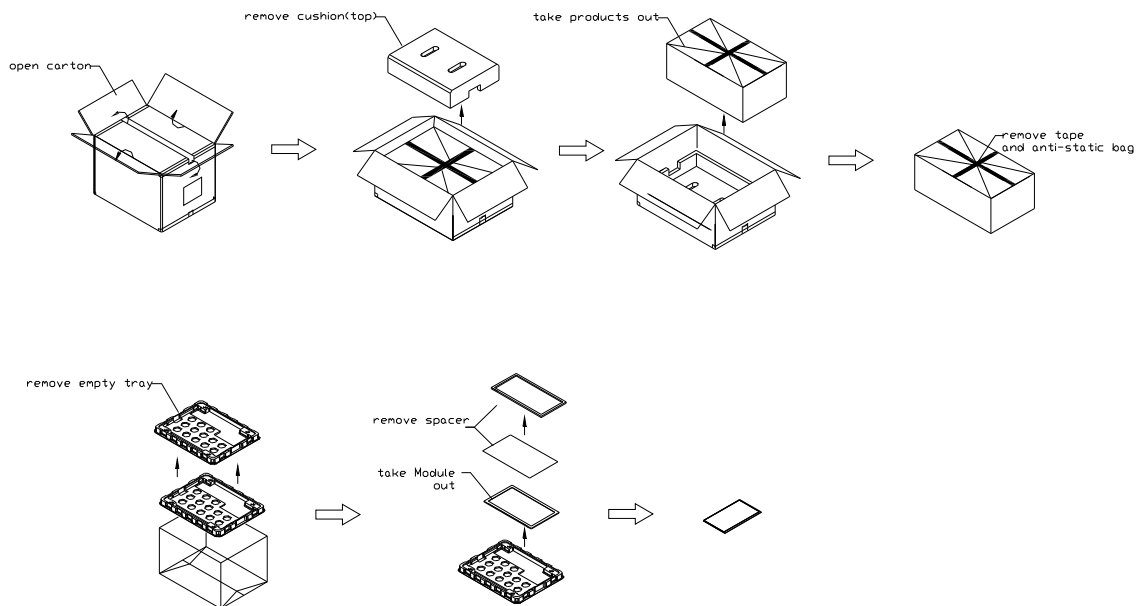
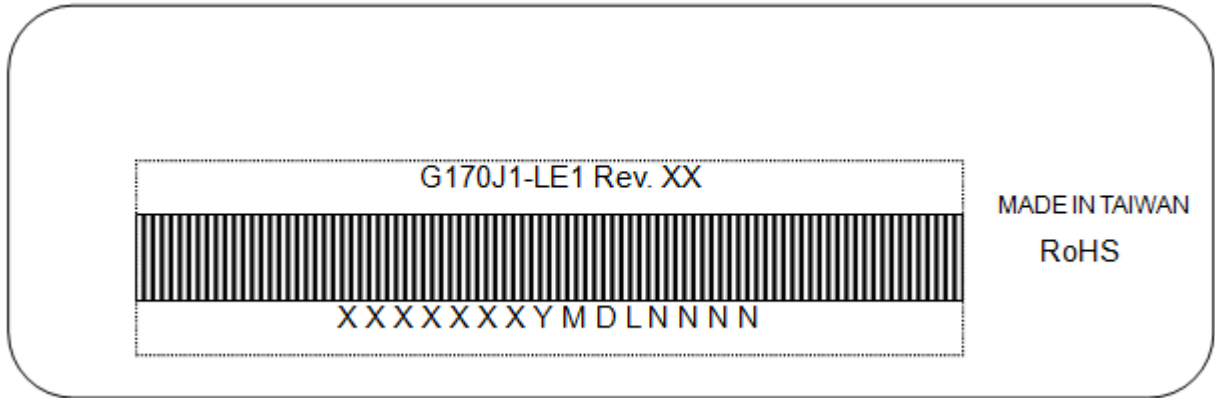

Figure. 9-3 UN-Packing method

10. DEFINITION OF LABELS

10.1 MODULE LABEL

The barcode nameplate is pasted on each module as illustration, and its definitions are as following explanation.



- (a) Model Name: G170J1-LE1
- (b) Revision: Rev. XX, for example: A0, A1... B1, B2... or C1, C2...etc.
- (c) Serial ID: XXXXXXXXYMDLNNNN

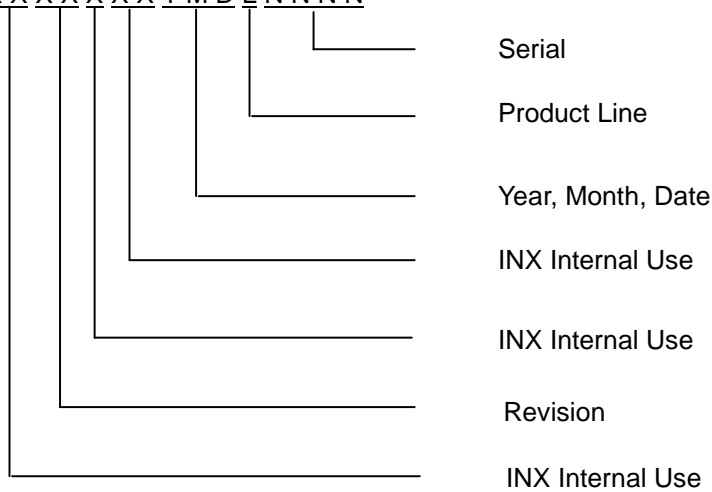

Serial ID includes the information as below:

- (a) Manufactured Date: Year: 0~9, for 2010~2019
 Month: 1~9, A~C, for Jan. ~ Dec.
 Day: 1~9, A~Y, for 1st to 31st, exclude I ,O, and U.
- (b) Revision Code: Cover all the change
- (c) Serial No.: Manufacturing sequence of product
- (d) Product Line: 1 -> Line1, 2 -> Line 2, ...etc.

10.2 OPTICAL LABEL

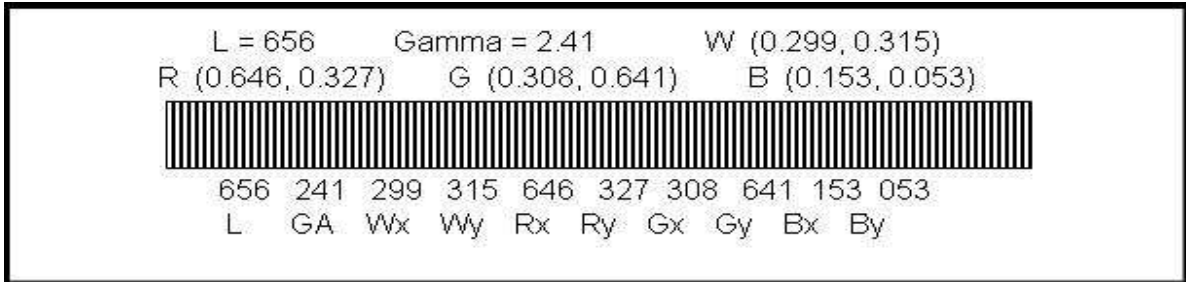

Data Format L, Gamma, W, R, G, B

Example : L=656nits, Gamma=2.41, W (0.299,0.315), R (0.646,0.327), G (0.308,0.641), B (0.153,0.053)

11. PRECAUTIONS

11.1 ASSEMBLY AND HANDLING PRECAUTIONS

- (1) Do not apply rough force such as bending or twisting to the module during assembly.
- (2) It is recommended to assemble or to install a module into the user's system in clean working areas. The dust and oil may cause electrical short or worsen the polarizer.
- (3) Do not apply pressure or impulse to the module to prevent the damage of LCD panel and Backlight.
- (4) Always follow the correct power-on sequence when the LCD module is turned on. This can prevent the damage and latch-up of the CMOS LSI chips.
- (5) Do not plug in or pull out the I/F connector while the module is in operation.
- (6) Do not disassemble the module.
- (7) Use a soft dry cloth without chemicals for cleaning, because the surface of polarizer is very soft and easily scratched.
- (8) Moisture can easily penetrate into LCD module and may cause the damage during operation.
- (9) High temperature or humidity may deteriorate the performance of LCD module. Please store LCD modules in the specified storage conditions.
- (10) When ambient temperature is lower than 10°C, the display quality might be reduced. For example, the response time will become slow, and the starting voltage of backlight will be higher than that of room temperature.
- (11) Do not keep same pattern in a long period of time. It may cause image sticking on LCD.

11.2 SAFETY PRECAUTIONS

- (1) If the liquid crystal material leaks from the panel, it should be kept away from the eyes or mouth. In case of contact with hands, skin or clothes, it has to be washed away thoroughly with soap.
- (2) After the module's end of life, it is not harmful in case of normal operation and storage.

12. MECHANICAL CHARACTERIS

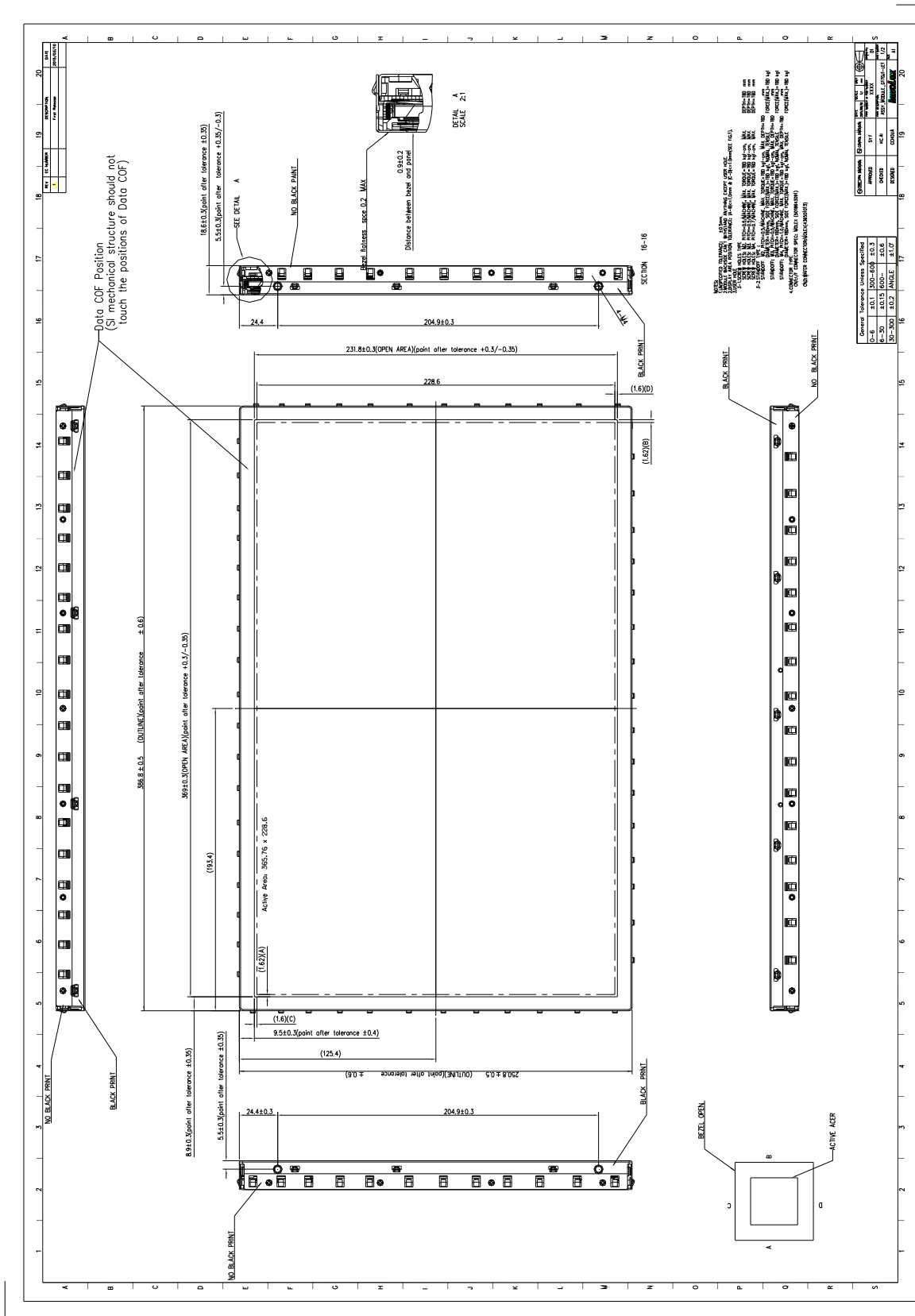

Our company network supports you worldwide with offices in Germany, Austria, Switzerland, the UK and the USA. For more information please contact:

Headquarters

Germany



FORTEC Elektronik AG

Augsburger Str. 2b
82110 Germering

Phone: +49 89 894450-0
E-Mail: info@forteca.de
Internet: www.forteca.de

Fortec Group Members

Austria



Distec GmbH Office Vienna

Nuschinggasse 12
1230 Wien

Phone: +43 1 8673492-0
E-Mail: info@distec.de
Internet: www.distec.de

Germany



Distec GmbH

Augsburger Str. 2b
82110 Germering

Phone: +49 89 894363-0
E-Mail: info@distec.de
Internet: www.distec.de

Switzerland



ALTRAC AG

Bahnhofstraße 3
5436 Würenlos

Phone: +41 44 7446111
E-Mail: info@altrac.ch
Internet: www.altrac.ch

United Kingdom



Display Technology Ltd.

Osprey House, 1 Osprey Court
Hichingbrooke Business Park
Huntingdon, Cambridgeshire, PE29 6FN

Phone: +44 1480 411600
E-Mail: info@displaytechnology.co.uk
Internet: www.displaytechnology.co.uk

USA



Apollo Display Technologies, Corp.

87 Raynor Avenue,
Unit 1 Ronkonkoma,
NY 11779

Phone: +1 631 5804360
E-Mail: info@apolloDisplays.com
Internet: www.apolloDisplays.com