



OUR GLOBAL  
COMPETENCE  
CENTRES

 APOLLO DISPLAY  
TECHNOLOGIES



 DISTEC



 DISPLAY  
TECHNOLOGY



# Datasheet

## Ortustech

7CA+\$<+A&I @

UÜÖÇFI

## Specifications for

# **Blanview TFT-LCD Monitor** **( 7.0" WVGA 800 x RGB x 480 Landscape)**

Version 3.0

(Please be sure to check the specifications latest version. )

**MODEL COM70H7M24ULC**

Customer's Approval
Signature:
Name:
Section:
Title:
Date:

# ORTUSTECH

TOPPAN PRINTING CO.,LTD.  
Electronics Division  
Ortus Subdivision

Approved by

\_\_\_\_\_ *Y. Nakajima*

Checked by

\_\_\_\_\_ *S. Kuwayama*

Prepared by

\_\_\_\_\_ *M. Jojo*

## Version History

Ver.	Date	Page	Description
0.0	Dec. 21, 2017	-	- Tentative issue
0.1 △ <sub>A</sub> ×1	Feb. 20, 2018	13	correction 7.2.1 LVDS DC Characteristics
0.2 △ <sub>B</sub> ×8	Jun.6, 2018	11 12 18 19 20 21 23 30	correction 5. Absolute Maximum Rating correction 7.1 DC Characteristics( BackLight ) correction 8. LED Circuit correction 9.1 Optical Characteristics correction 9.2 Temperature Characteristics correction 10.1 Defective Display and Screen Quality correction 11. Reliability Test correction APPENDIX 1. Measurement Condition (Backlight ON)
0.3 △ <sub>C</sub> ×8	Dec.18, 2018	7 19 20 20 23 25 30 32	add Weight correction Measuring instruments: CS2000→CS1000, transcription of response time add White Chromaticity Range correction Measuring instruments: CS2000→CS1000, transcription of response time and contrast ratio add Lightfastness add Packing Specifications correction Measuring instruments: CS2000→CS1000 correction Measuring instruments: CS2000→CS1000 Diameter of measuring point: 1mmφ→8mmφ
0.4 △ <sub>D</sub> ×9	Feb.6, 2019	7 11 15 19 21 23	add Surface hardness of the polarizer add Forward current add Operating Current correction The location of the arrow of 'Previous cycle' and 'Next cycle' add MIN value of the time of backlight on add The center brightness MIN value at IL=20mA add Signal condition add Indicative data of a dark dot add Surface discharge test (Non operation)
1.0 △ <sub>E</sub> ×11	Jun.19,2019	All page 4 5 19 20 23 30 30 32	correction It is a company name change from ORTUS TECHNOLOGY CO.,LTD to TOPPAN PRINTING CO.,LTD. add Compatible for RoHS(2.0) directive. correction Signal input method correction Measuring instruments: CS1000→CS2000, contrast (backlight ON) add condition correction Measuring instruments: CS1000→CS2000 add unit add number of failures / number of examinations correction Measuring instruments: CS1000→CS2000 correction Measuring instruments: CS1000→CS2000, distance between TFT monitor and luminance meter correction Test method
2.0 △ <sub>A</sub> ×1	Mar.31,2020	8	add Marking line
3.0 △ <sub>G</sub> ×4	Mar.31,2021	19 23 30 32	change Measuring instruments change Test condition (Vibration test ) correction Temperature / humidity profile diagram change Measuring instruments change Measuring instruments

## Contents

1. Application	.....	4
2. Outline Specifications		
2.1 Features of the Product	.....	5
2.2 Display Method	.....	5
3. Dimensions and Outward Form		
3.1 Dimensions	.....	7
3.2 Outward Form	.....	8
3.3 Serial Label (S-LABEL)	.....	9
4. Pin Assignment	.....	10
5. Absolute Maximum Rating	.....	11
6. Recommended Operating Conditions	.....	11
7. Electrical Characteristics		
7.1 DC Characteristics	.....	11
7.2 LVDS interface		
7.2.1 LVDS DC Characteristics	.....	13
7.2.2 LVDS AC Characteristics	.....	14
7.2.3 LVDS Data Format	.....	15
7.3 Input Timing	.....	16
7.4 Power-ON/OFF Sequence	.....	17
8. LED Circuit	.....	18
9. Characteristics		
9.1 Optical Characteristics	.....	19
9.2 Temperature Characteristics	.....	20
10. Criteria of Judgment		
10.1 Defective Display and Screen Quality	.....	21
10.2 Screen and Other Appearance	.....	22
11. Reliability Test	.....	23
12. Packing Specifications	.....	25
13. Handling Instruction		
13.1 Cautions for Handling LCD panels	.....	26
13.2 Precautions for Handling	.....	27
13.3 Precautions for Operation	.....	27
13.4 Storage Condition for Shipping Cartons	.....	28
13.5 Precautions for Peeling off the Protective film	.....	29
13.6 Warranty	.....	29
APPENDIX	.....	30

## 1. Application

This Specification is applicable to 178 mm (7.0 inch) Blanview TFT-LCD monitor for non-military use.

- ◎ TOPPAN PRINTING makes no warranty or assume no liability that use of this Product and/or any information including drawings in this Specification by Purchaser is not infringing any patent or other intellectual property rights owned by third parties, and TOPPAN PRINTING shall not grant to Purchaser any right to use any patent or other intellectual property rights owned by third parties. Since this Specification contains TOPPAN PRINTING's confidential information and copy right, Purchaser shall use them with high degree of care to prevent any unauthorized use, disclosure, duplication, publication or dissemination of TOPPAN PRINTING's confidential information and copy right.
- ◎ If Purchaser intends to use this Products for an application which requires higher level of reliability and/or safety in functionality and/or accuracy such as transport equipment (aircraft, train, automobile, etc.), disaster-prevention/security equipment or various safety equipment, Purchaser shall consult TOPPAN PRINTING on such use in advance.
- ◎ This Product shall not be used for application which requires extremely higher level of reliability and/or safety such as aerospace equipment, telecommunication equipment for trunk lines, control equipment for nuclear facilities or life-support medical equipment.
- ◎ It must be noted as an mechanical design manner, especial attention in housing design to prevent arcuation/flexure or caused by stress to the LCD module shall be considered.
- ◎ TOPPAN PRINTING assumes no liability for any damage resulting from misuse, abuse, and/or miss-operation of the Product deviating from the operating conditions and precautions described in the Specification.
- ◎ It shall be mutually conferred if nonconforming defect which result from unspecified cause in this specification arises.
- ◎ If any issue arises as to information provided in this Specification or any other information, TOPPAN PRINTING and Purchaser shall discuss them in good faith and seek solution.
- ◎ TOPPAN PRINTING assumes no liability for defects such as electrostatic discharge failure occurred during peeling off the protective film or Purchaser's assembly process.
- ◎ This Product is compatible for RoHS(2.0) directive.

Object substance	Maximum content [ppm]
Cadmium and its compound	100
Hexavalent Chromium Compound	1000
Lead & Lead compound	1000
Mercury & Mercury compound	1000
Polybrominated biphenyl series (PBB series)	1000
Polybrominated biphenyl ether series (PBDE series)	1000
Bis(2-ethylhexyl)phthalate series (DEHP series)	1000
Butyl benzyl phthalate series (BBP series)	1000
Dibutyl phthalate series (DBP series)	1000
Diisobutyl phthalate series (DIBP series)	1000



<Features of Blanview>

- Backlight power consumption required to assure visibility. (equivalent to 3.5"QVGA )

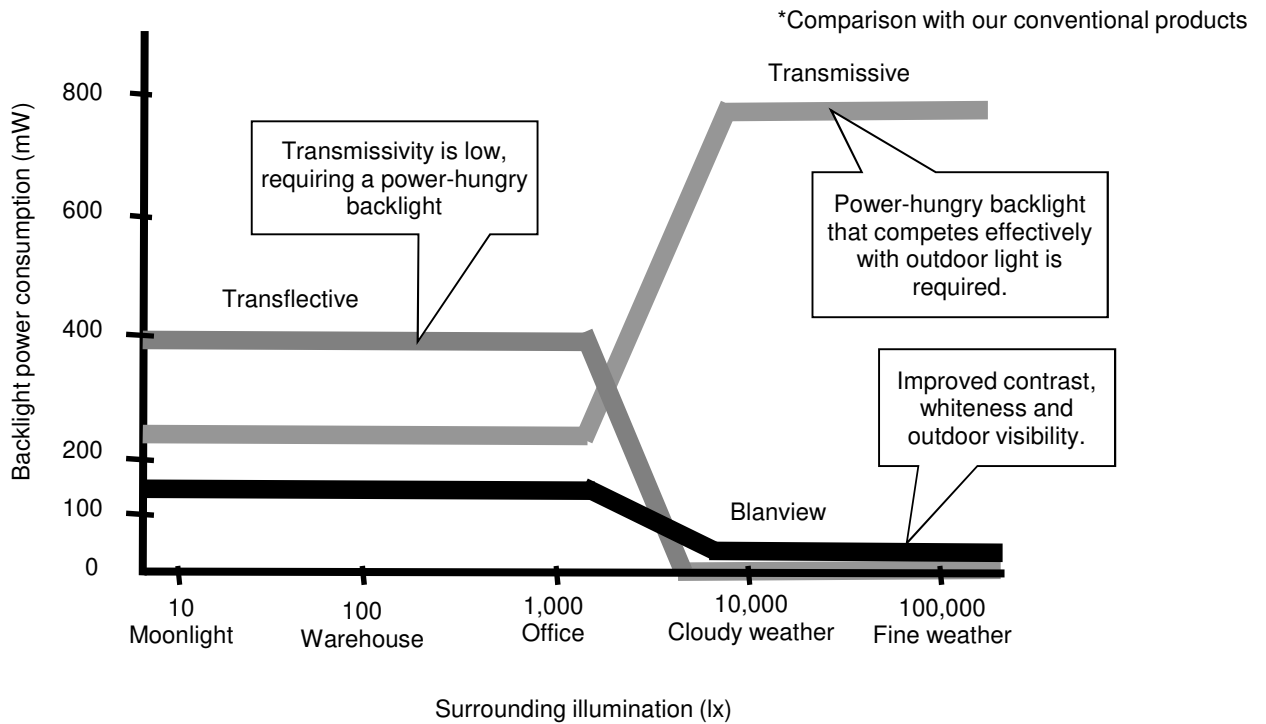

- Contrast characteristics under 100,000lx. (same condition as direct sunlight.)

With better contrast (higher contrast ratio), Blanview TFT-LCD has the best outdoor readability in three different types of TFT-LCD.

Below chart shows contrast value against panel surface brightness. (Horizontal: Panel surface brightness/ Vertical: Contrast value) LCD panel has enough outdoor readability above our Standard line. (TOPPAN PRINTING criteria)

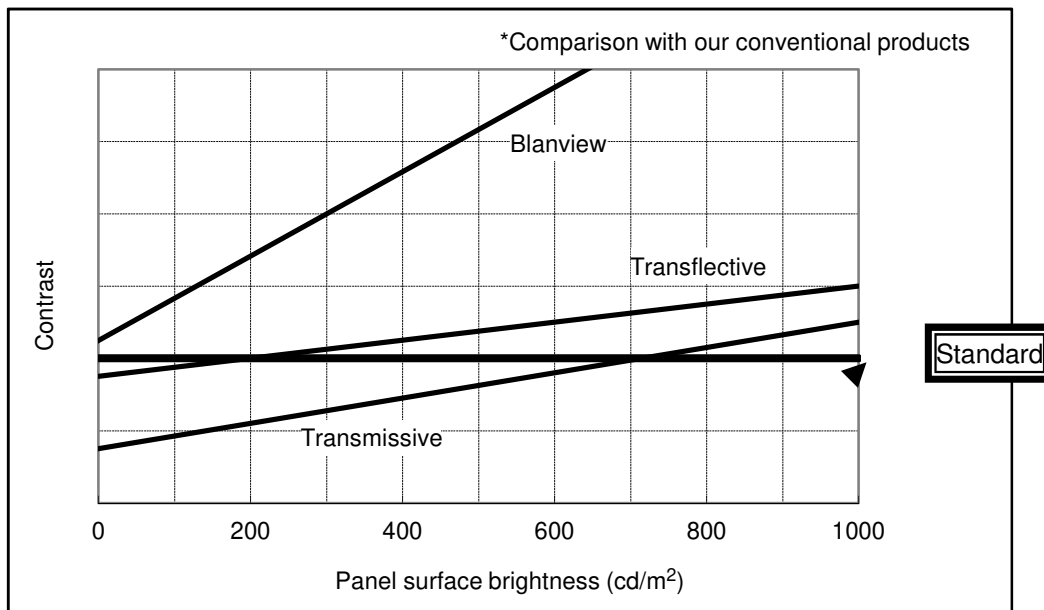



## 3. Dimensions and Outward Form

## 3.1 Dimensions

Items	Specifications	Unit	Remarks
Outline dimensions	169.80[H] × 109.70[V] × 6.08 [D]	mm	Exclude FPC cable and parts on FPC.
Active area	152.40[H] × 91.44[V]	mm	178mm diagonal
Number of dots	2400[H] × 480[V]	dot	
Dot pitch	63.5[H] × 190.5[V]	um	
Surface hardness of the polarizer	3	H	Load:4.9N
Weight	170	g	Include FPC cable

3.2 Outward Form

EC No.	REV. No.	REVISE	DATE (Y.M.D)	APPROVED	CHECKED	PREPARED
	△ X 1	ケガキ線追加	20:03:25	尾木	加藤	前田

(8/32)  
17TLM036  
Issue: Mar. 31, 2021

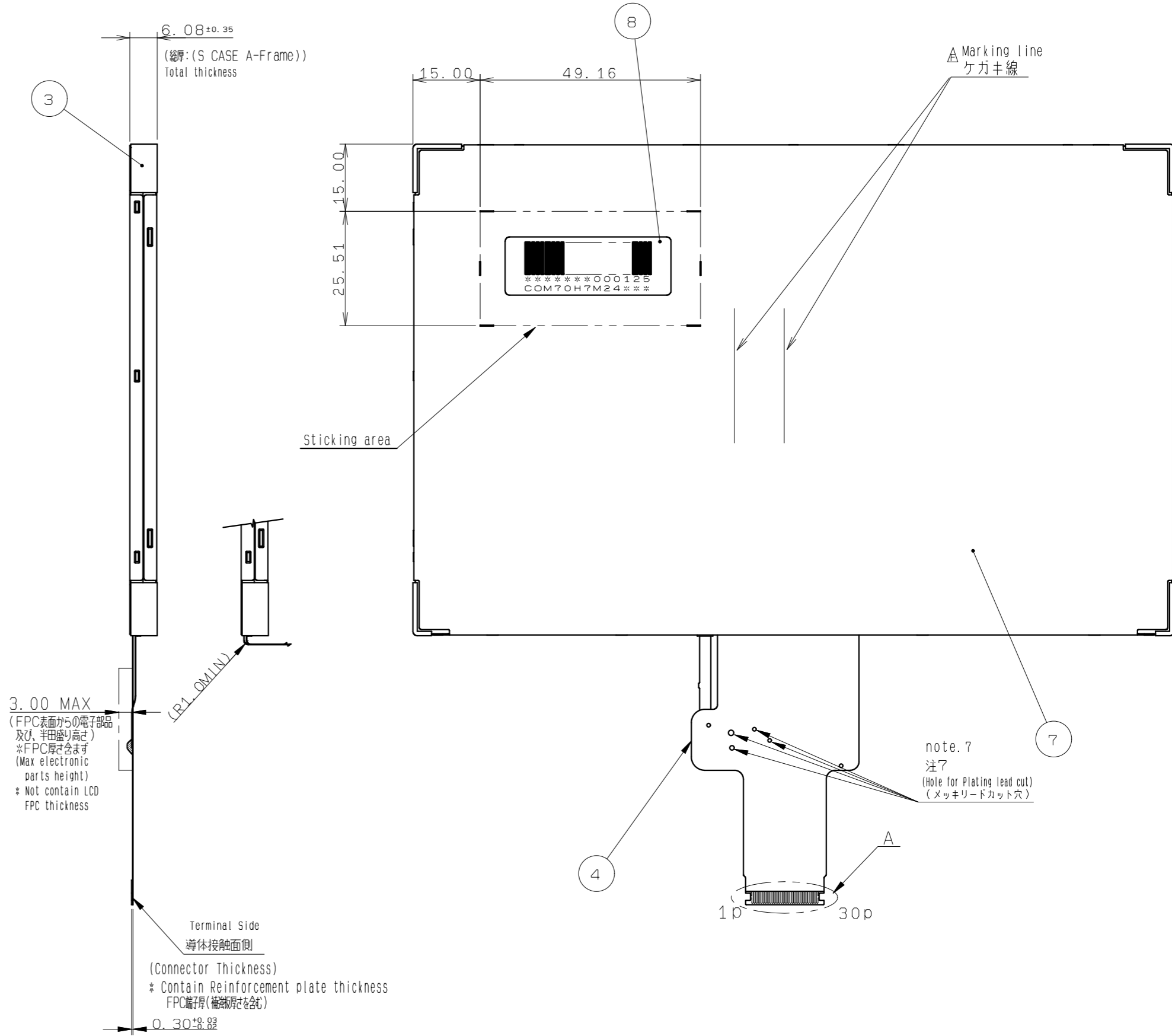
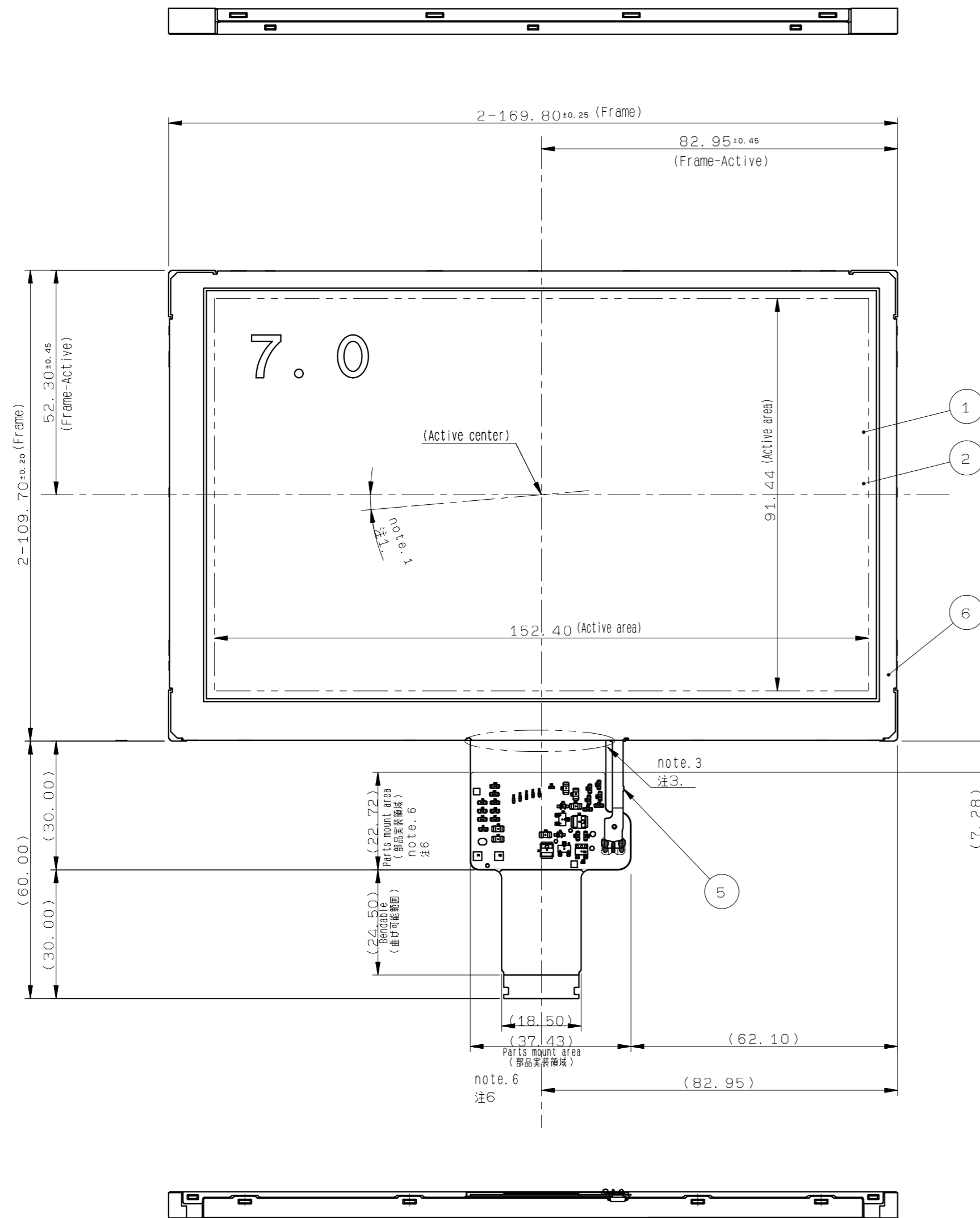

3.00 MAX  
(FPC表面からの電子部品及び、半田盛り高さ)  
\*FPC厚さ含まず  
(Max electronic parts height)  
\* Not contain LCD FPC thickness

note. 7  
注7  
(Hole for Plating lead cut)  
(メッキリードカット穴)

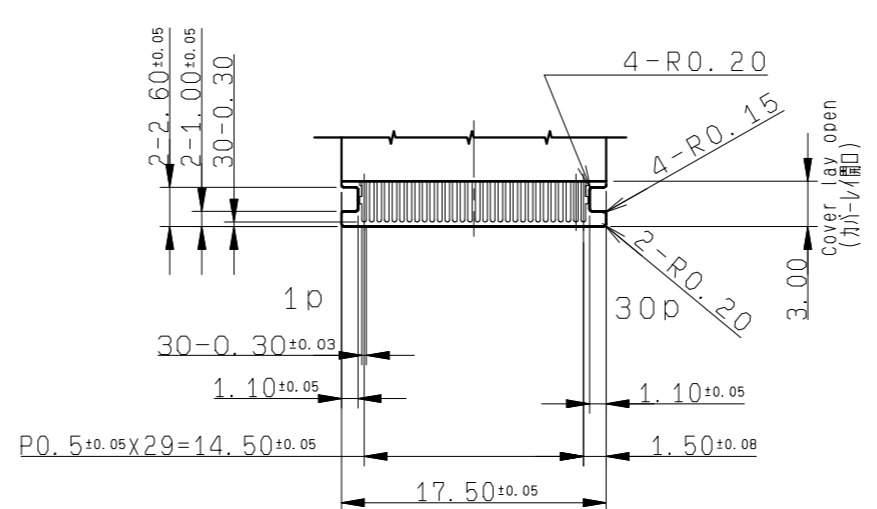

DETAIL A note. 4  
(S=2/1) 注4

Angular deviation of LCD cell from the TFT-LCD monitor's reference axis shall be less than  $\pm 150'$ .  
注1. TFT-LCD PANELの角度スレは、モニター基準軸に対し $\pm 150'$ 以下とする。  
Protective film is affixed on front surface of the screen.  
Protective film is not protrude from the outline of the monitor.  
2. 保護膜が表面側に貼られる。  
保護膜はモニター外形からはみ出さないものとする。  
Don't stress to FPC bonding area & the solder area.  
3. FPCの圧着部及び半田接続部には負荷の掛からないようご注意ください。  
Recommended FPC connectors  
: IR150/IMS A-9699S-30A-GFN1(Lower contact)  
4. FPCの推奨コネクタの規格を下記に示す。  
IRISO:9699 series (IMS A-9699S-30A-GFN1(下接点))

Burrs direction of S CASE is outward. (Burrs size is less than 0.03mm.)  
5. S CASEのバリ方向は外側になります。(MAX0.03mm)  
Don't touch any conductive material to conductive area.  
6. 導体開口部は導体部品との接触を避けてください。  
Don't touch any conductive material to plating cut area.  
7. メッキリードカット位置は導体部品との接触を避けてください。

S LABEL	8	Barcode(CODE39)	For Monitor	(37x13x0.075t)
S CASE C	7		SUS (t=0.30)	
S CASE A	6		SUS (t=0.15)	
FPC B	5			Use of LED
FPC A	4		AU/Ni plating AU/Niソルダ	Use of LCD
Frame	3		PC	
Polarizer	2			
TFT-LCD PANEL	1		Glass thickness=0.50±0.50t	
PART NAME	ITEM	PART CODE	MODEL NUMBER	REMARK
APPROVED 尾木	GENERAL TOLERANCE $\pm 0.5$	SCALE 1/1	UNIT mm	<b>TOPPAN</b> TOPPAN PRINTING CO., LTD. DO NOT DUPLICATE, CONFIDENTIAL AND PROPRIETARY
CHECKED 木下	ISSUE (Y.M.D) 19:04:19	MODEL CCM70H7M24U**		
CHECKED	NAME			
DESIGN 前田創				
DRAW 前田創				
OUTLINE-D7M24				DRAWING No. RJD530212D201 REV. SHEET DIV. / / ASS'Y

### 3.3 Serial Label (S-LABEL)

#### 1) Indication

A section : Bar code

B section : Combination of a character

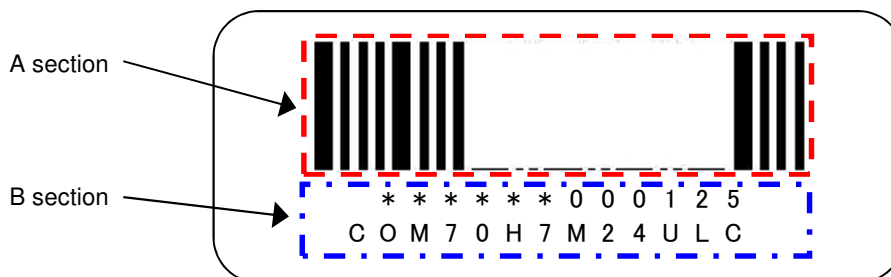

#### Details of B section

Upper column: It indicates the least significant digit of manufacture year (1 digit), manufacture month with below alphabet (1letter), model code (4characters), serial number (6digits).

*	*	****	*****
-	-	---	-----
a	b	c	d

	Contents of display							
a	The least significant digit of manufacture year							
b	Manufacture month	Jan-A	Mar-C	May-E	Jul-G	Sep-I	Nov-K	
		Feb-B	Apr-D	Jun-F	Aug-H	Oct-J	Dec-L	
c	Model code	70VC (Made in Japan)					70WC (Made in Malaysia)	
d	Serial number							

\* Example of indication of Serial label (S-label)

•Made in Japan

9 J 7 0 V C 0 0 0 1 2 5

means "manufactured in October 2019, 7" V type, C specifications, serial number 000125"

•Made in Malaysia

9 J 7 0 W C 0 0 0 1 2 5

means "manufactured in October 2019, 7" W type, C specifications, serial number 000125"

Lower column: Model (13characters)

#### 2) Location of Serial Label (S-label)

Refer to 3.2 "Outward Form".

#### 3) Others

Bar code readability is excluded from quality assurance coverage.

## 4. Pin Assignment

No.	Symbol	Function	I/O
1	BLH	LED drive power source. (Anode side)	P
2	BLL2	LED drive power source . (Cathode side 2)	P
3	BLL1	LED drive power source . (Cathode side 1)	P
4	GND	Ground	P
5	VDD	Power supply input.	P
6	VDD	Power supply input.	P
7	TEST1	TEST input (Connect to VDD)	I
8	TEST2	TEST input (Connect to GND)	I
9	TEST3	TEST input (Connect to GND)	I
10	NC	No connection	-
11	UL/DR	Up & Left / Down & Right switching terminal ( Low : DR , High or NC : UL )	I
12	IM	6 / 8 bit (based on VESA ) switching terminal ( Low : 6bit , High or NC : 8bit )	I
13	STBYB	Standby signal (Low:Standby operation,High:Normal operation)	I
14	GND	Ground	P
15	R0-	LVDS DATA0(-)	I
16	R0+	LVDS DATA0(+)	I
17	GND	Ground	P
18	R1-	LVDS DATA1(-)	I
19	R1+	LVDS DATA1(+)	I
20	GND	Ground	P
21	CLK-	LVDS CLK(-)	I
22	CLK+	LVDS CLK(+)	I
23	GND	Ground	P
24	R2-	LVDS DATA2(-)	I
25	R2+	LVDS DATA2(+)	I
26	GND	Ground	P
27	R3-	LVDS DATA3(-)	I
28	R3+	LVDS DATA3(+)	I
29	GND	Ground	P
30	NC	No connection	-

- Recommended connector : IRISO ELECTRONICS 9699 series [IMSA-9699S-30A-GFN1]
- Please be sure to check a consistency between pin assignment in "3.2 Outward Form" and your connector pin assignment when designing your circuit.  
Inconsistency in input signal assignment may cause a malfunction.
- Since FPC cable has gold plated terminals, gilt finish contact shoe connector is recommended.

## 5. Absolute Maximum Rating

GND=0V

Item	Symbol	Condition	Rating		Unit	Applicable terminal
			MIN	MAX		
Supply voltage	VDD		-0.3	3.9	V	VDD
Input voltage for logic	VI		-0.3	VDD+0.3	V	UL/DR, IM, STBYB
Forward current	IL1,IL2		--	75	mA	BLH-BLL1/BLL2
Storage temperature range	Tstg		-40	95	°C	

## 6. Recommended Operating Conditions

GND=0V

Item	Symbol	Condition	Rating			Unit	Applicable terminal
			MIN	TYP	MAX		
Supply voltage	VDD		3.0	3.3	3.6	V	VDD
Input voltage for logic	VI		0	--	VDD	V	UL/DR, IM, STBYB
Operational temperature range	Top	Note1	-30	+25	+85	°C	Panel surface temperature

Note1: This monitor is operable in this temperature range. With regard to optical characteristics, refer to Item 9."CHARACTERISTICS".

## 7. Electrical Characteristics

## 7.1 DC Characteristics

(Unless otherwise noted, Ta=25 °C, VDD=3.3V, GND=0V)

Item	Symbol	Condition	Rating			Unit	Applicable terminal
			MIN	TYP	MAX		
High Level Input Voltage	VIH		0.7VDD	—	VDD	V	UL/DR,IM,STBYB
Low Level Input Voltage	VIL		0	—	0.3VDD	V	
Pull up/down resistor	RI		200	350	850	kΩ	Pull up : IM, STBYB
			100	175	425	kΩ	Pull up : UL/DR
Operating Current	IDD	Color Bar fclk = 27.2 MHz	—	38	76	mA	VDD

( BackLight )

Item	Symbol	Condition	Rating			Unit	Applicable terminal
			MIN	TYP	MAX		
Forward current	IL1	Ta=25 °C , Note1	--	20	60	mA	BLH - BLL1
	IL2		--	20	60	mA	BLH - BLL2
Forward voltage *Reference value	VF1	Ta=25 °C	--	21.9	25.0	V	BLH - BLL1
	VF2	IL1=IL2=20mA	--	21.9	25.0	V	BLH - BLL2
Estimated Life of LED	LL	Ta=25 °C Note2 IL1=IL2=20mA	--	100,000	--	hrs	

Note1: - Please control so that each current does not vary (IL1 = IL2).

Note2: - The lifetime of the LED is defined as a period till the brightness of the LED decreases to the half of its initial value.

- This figure is given as a reference purpose only, and not as a guarantee.

- This figure is estimated for an LED operating alone.

As the performance of an LED may differ when assembled as a monitor together with a TFT panel due to different environmental temperature.

- Estimated lifetime could vary on a different temperature and usually higher temperature could reduce the life significantly.

## 7.2 LVDS interface

### 7.2.1 LVDS DC Characteristics

(Unless otherwise noted,  $T_a=25\text{ }^\circ\text{C}$ ,  $V_{DD}=3.3\text{V}$ ,  $GND=0\text{V}$ )

Item	Symbol	Condition	Rating			Unit	Applicable terminal
			MIN	TYP	MAX		
Differential input high threshold voltage	Rxvth	Rxvcm=1.2V	-	-	0.1	V	CLK+, CLK- R0+, R0-, R1+, R1- R2+, R2-, R3+, R3-
Differential input low threshold voltage	Rxvtl		-0.1	-	-	V	
Differential input common Mode voltage	Rxvcm		1.0	1.2	$1.8- V_{ID} /2$	V	
Differential input voltage	$ V_{ID} $		0.2	-	0.6	V	
Differential input leakage current	$RV_{leak}$		-10	-	+10	$\mu\text{A}$	

#### Single end signals

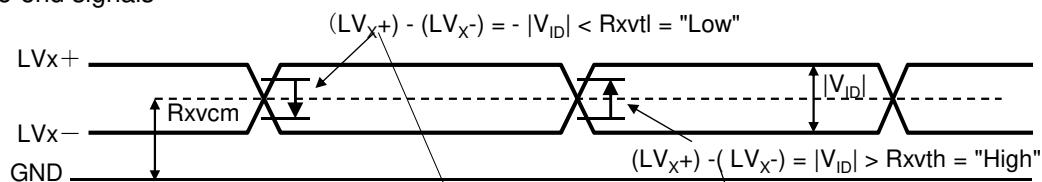

#### Differential signals

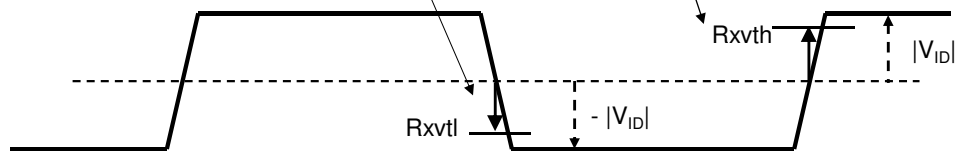

## 7.2.2 LVDS AC Characteristics

(Unless otherwise noted,  $T_a=25\text{ }^\circ\text{C}$ ,  $V_{DD}=3.3\text{V}$ ,  $GND=0\text{V}$ )

Item	Symbol	Rating			Unit	
		MIN	TYP	MAX		
CLK Frequency	f clk	25.2	27.2	30.5	MHz	
Clock period	Tc	32.8	36.8	39.7	ns	
1 data bit time	UI	-	1/7	-	Tc	
CLK High level Width	T chw	2.9	4	4.1	UI	
CLK Low level Width	T clw	2.9	3	4.1	UI	
Position 1	Tpos_1	-0.2	0	0.2	UI	
Position 0	Tpos_0	0.8	1	1.2	UI	
Position 6	Tpos_6	1.8	2	2.2	UI	
Position 5	Tpos_5	2.8	3	3.2	UI	
Position 4	Tpos_4	3.8	4	4.2	UI	
Position 3	Tpos_3	4.8	5	5.2	UI	
Position 2	Tpos_2	5.8	6	6.2	UI	
Reciever Strobe Position 7	TEYEW	0.6	-	-	UI	
Reciever Strobe Position 8	TEX	-	-	0.2	UI	

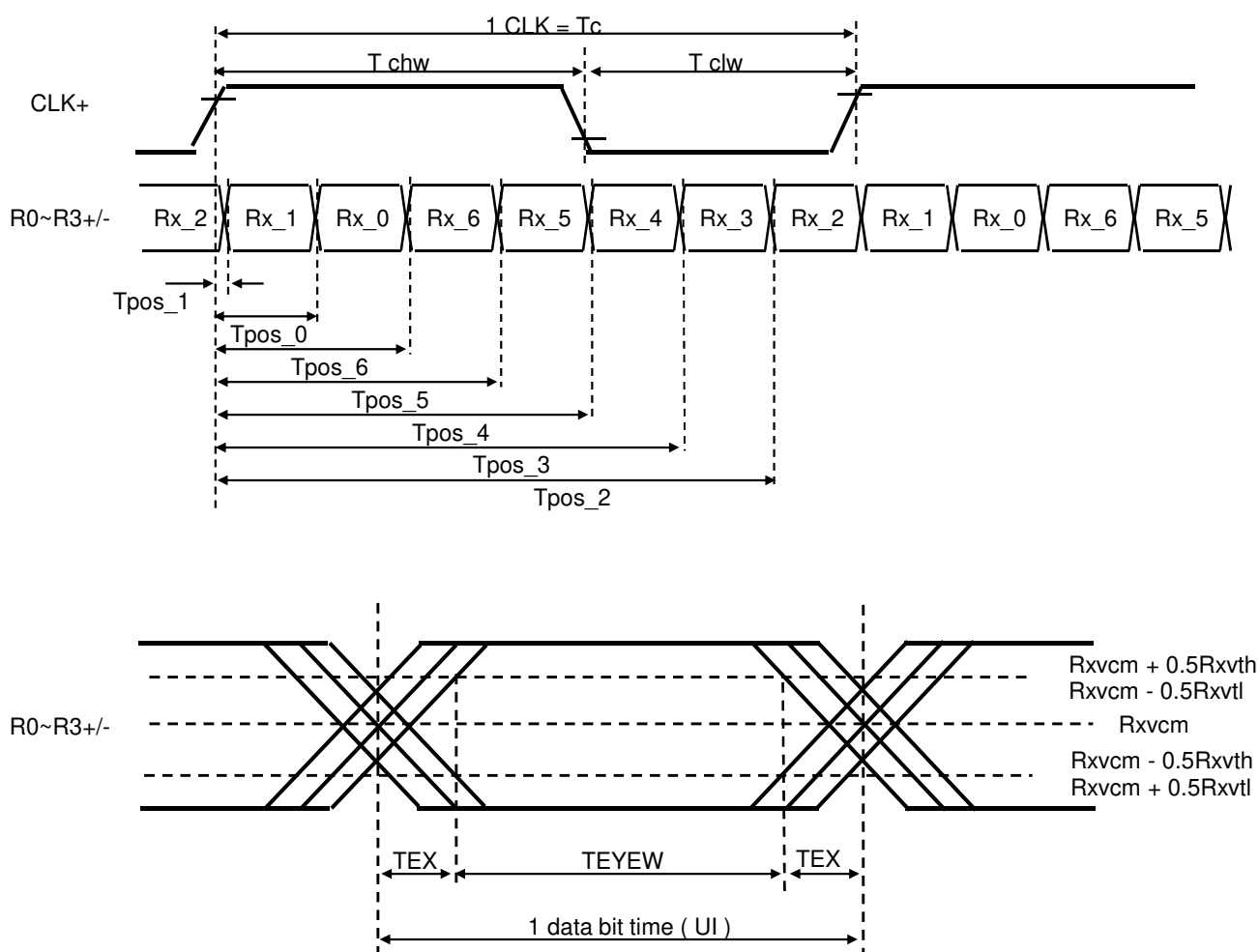





### 7.3 Input timing

Item	Symbol	Rating			Unit	Signal ( * )
		MIN	TYP	MAX		
CLK frequency	fCLK	25.2	27.2	30.5	MHz	CLK
VD frequency	fVD	-	60	-	Hz	VD
1 vertical field	tv	490	528	552	H	
VD pulse width	tvp	1	2	66	H	
VD back porch	tvb	5	10	67	H	VD,HD,ENAB
VD front porch	tvf	5	38	67	H	R[7:0],G[7:0],B[7:0]
Vertical valid data	tvdp		480		H	
HD frequency	fHD	-	28.8	-	kHz	HD
1 horizontal field	th	856	860	920	CLK	
HD pulse width	thp	1	2	100	CLK	
HD back porch	thb	5	16	101	CLK	CLK,HD,ENAB
HD front porch	thf	19	44	115	CLK	R[7:0],G[7:0],B[7:0]
ENAB pulse width	tenp		800		CLK	
Horizontal valid data	thdp		800		CLK	

( \* ) Input terminals are (R0+/- , R1+/- , R2+/- , R3+/- , CLK+/-).

#### <Vertical timing>

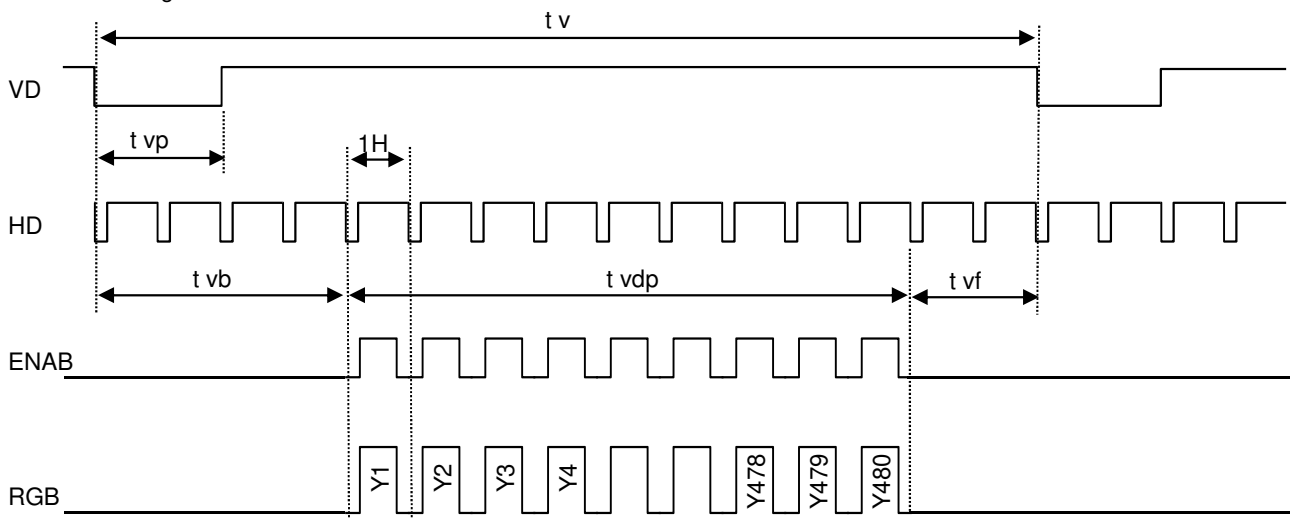

#### <Horizontal timing>

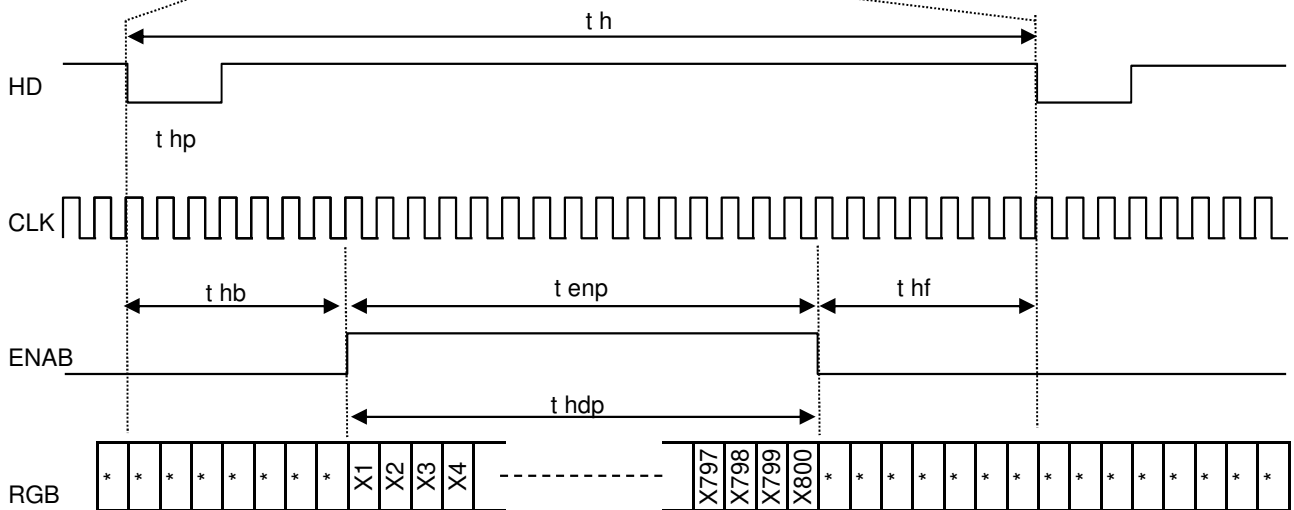

7.4 Power ON/OFF sequence

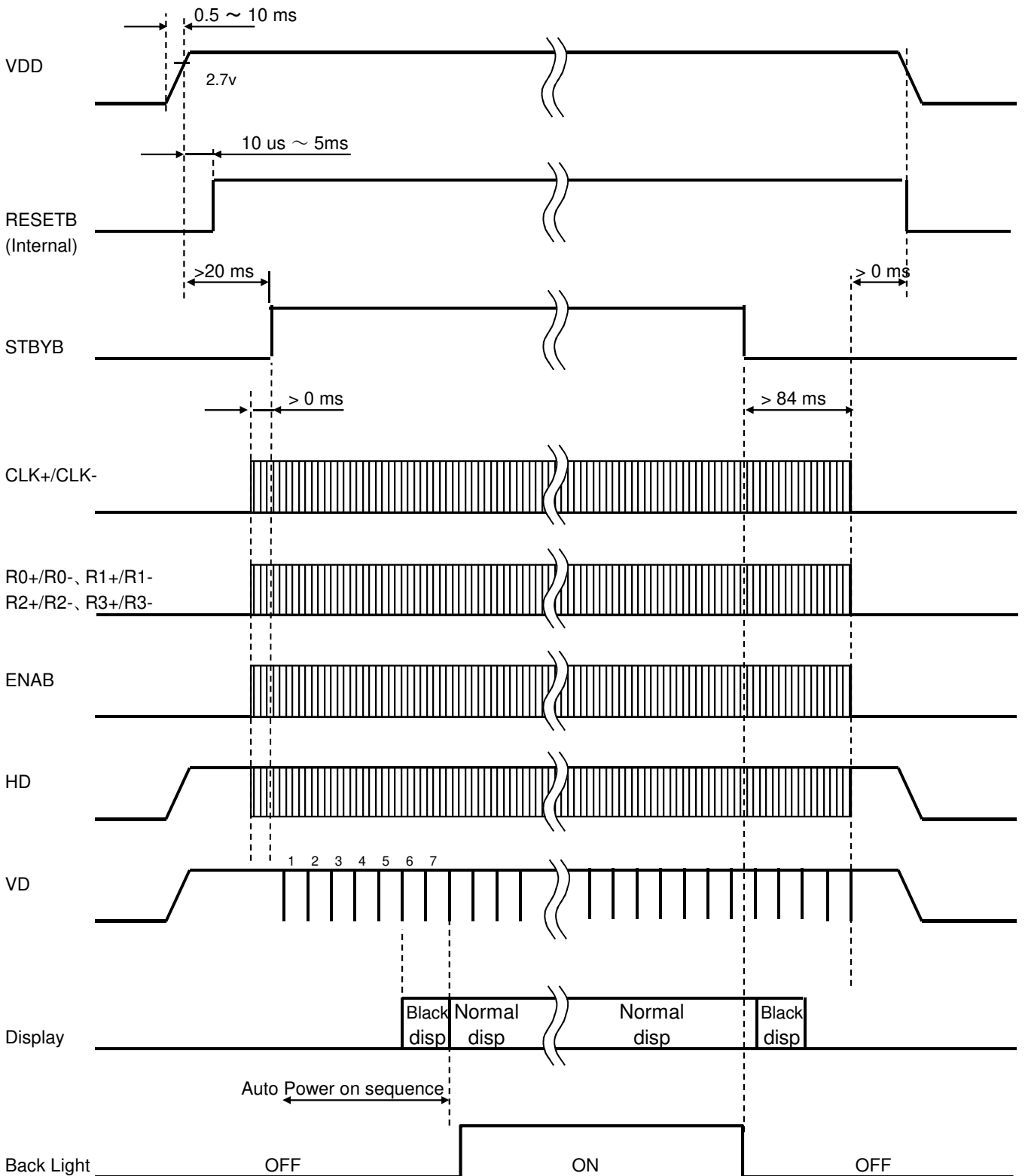

Note: ENAB, HD and VD are included in the R2 + / R2- terminals.

8. LED Circuit

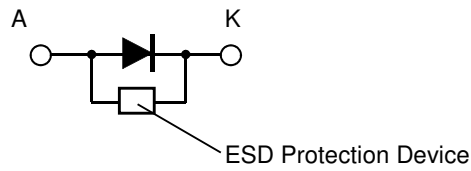
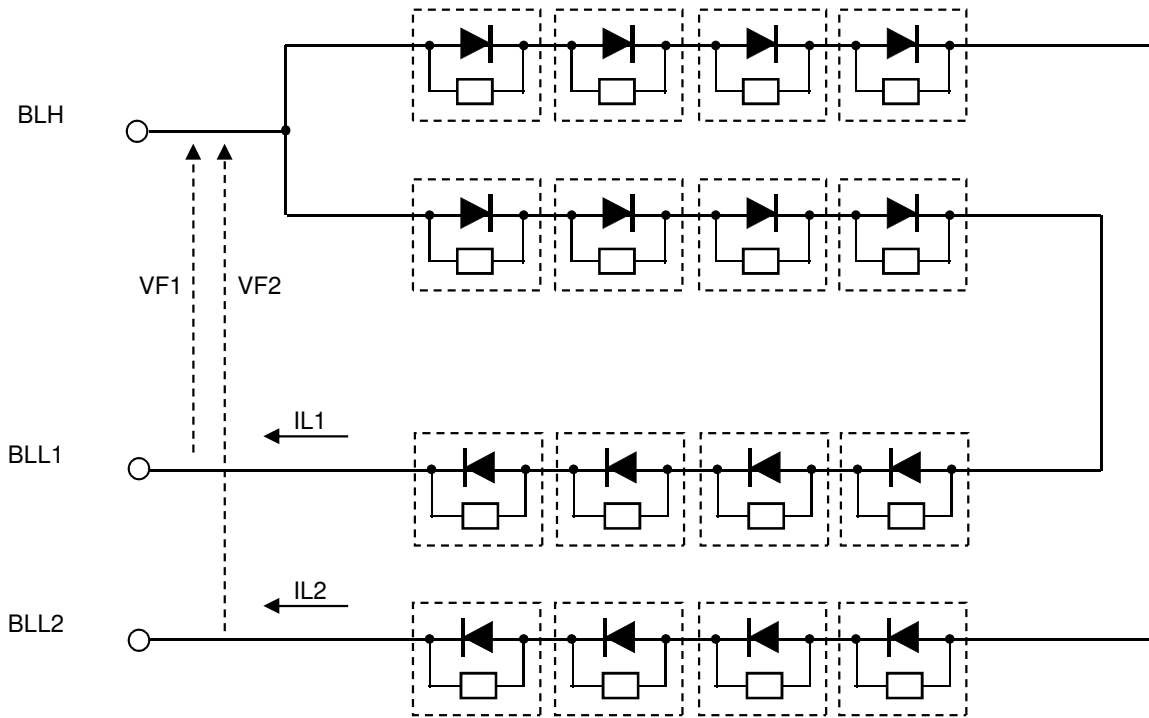

\* It is recommended to control currents of BLL1 / BLL2 to equal current values ( $IL1 = IL2$ ).

## 9. Characteristics

## 9.1 Optical Characteristics

&lt; Measurement Condition &gt;

Measuring instruments: CS2000 (KONICA MINOLTA), LCD7200 (OTSUKA ELECTRONICS), EZcontrastXL88 (ELDIM)

Driving condition: VDD=3.3V,GND=0V

Optimized VCOMDC

Backlight: IL1=IL2=20mA

Measured temperature: Ta=25° C

Item		Symbol	Condition	MIN	TYP	MAX	Unit	Note No.	Remark
Response time	Rise time + Fall time	TON	[Data]= 00h→FFh	-	50	100	ms	1	
		TOFF	[Data]= FFh→00h						
Contrast ratio	Backlight ON	CR	[Data]= FFh / 00h	350	700	-		2	
	Backlight OFF			-	3	-			
Viewing angle	Left	θL	[Data]= FFh / 00h CR ≥ 10	80	-	-	deg	3	
	Right	θR		80	-	-	deg		
	Up	φU		80	-	-	deg		
	Down	φD		80	-	-	deg		
White Chromaticity	x	[Data]=FFh	White chromaticity range					4	
	y								
Burn-in				No noticeable burn-in image shall be observed after 2 hours of window pattern display.				5	
Center brightness		[Data]=FFh		-	790	-	cd/m <sup>2</sup>	6	IL1=IL2=40mA
				240	400	-			IL1=IL2=20mA
Brightness distribution		[Data]=FFh		70	-	-	%	7	

\* Note number 1 to 7: Refer to the APPENDIX of "Reference Method for Measuring Optical Characteristics".

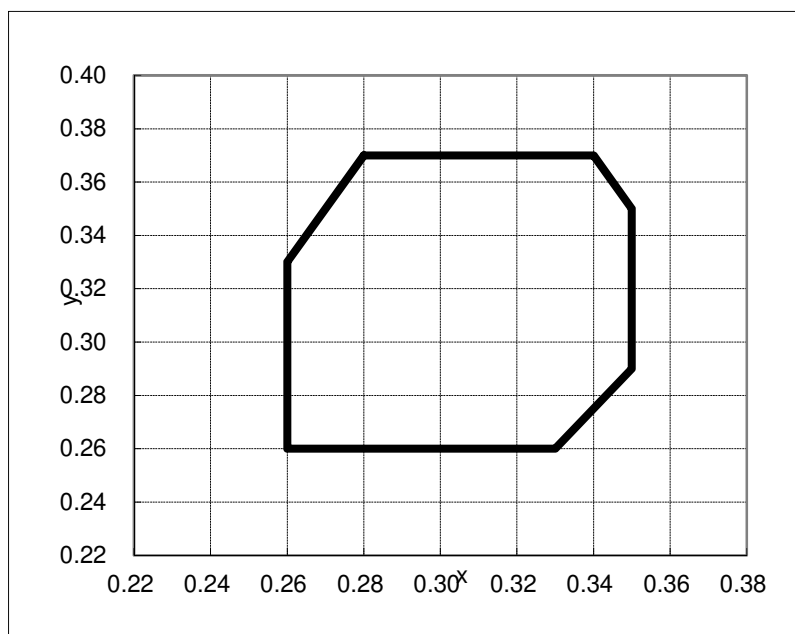

【White Chromaticity Range】

x	y
0.28	0.37
0.26	0.33
0.26	0.26
0.33	0.26
0.35	0.29
0.35	0.35
0.34	0.37

White Chromaticity Range

## 9.2 Temperature Characteristics

< Measurement Condition >

Measuring instruments: CS2000 (KONICA MINOLTA), LCD7200 (OTSUKA ELECTRONICS)

Driving condition: VDD=3.3V, GND=0V

Optimized VCOMDC

Backlight: IL1=IL2=20mA

Item	Symbol	Specification			Remark	
		MIN	TYP	MAX		
Contrast ratio	CR	200	-	-	Ta=-30°C Backlight ON	
		200	-	-	Ta=85°C Backlight ON	
Response time	Rise time + Fall time	TON + TOFF	-	980ms	1500ms	Ta=-30°C
			-	40ms	80ms	Ta=85°C
Display Quality		No noticeable display defect or ununiformity should be observed.				

## 10. Criteria of Judgment

## 10.1 Defective Display and Screen Quality

Test Condition: Observed TFT-LCD monitor from front during operation  
with the following conditions

Driving Signal Raster Pattern (RGB, white, black)

Signal condition [Data]:00h, 94h, FFh (3steps)

Observation distance 30 cm

Illuminance 200 to 350 lx

Backlight IL1=IL2=20mA

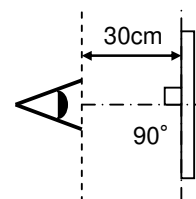

Defect item	Defect content		Criteria	
Display Quality	Line defect	Black, white or color line, 3 or more neighboring defective dots	Not exists	
	Dot defect	Uneven brightness on dot-by-dot base due to defective TFT or CF, or dust is counted as dot defect (brighter dot, darker dot)	Refer to table 1	
		High bright dot: Visible through 2% ND filter at [Data]=00h	Acceptable	
		Low bright dot: Visible through 5% ND filter at [Data]=00h Dark dot: Appear dark through white display at [Data]=94h Invisible through 5% ND filter at [Data]=00h		
Screen Quality	Dirt	Uneven brightness (white stain, black stain etc)	Invisible through 5% ND filter at Black screen. Invisible through 1% ND filter at other screen.	
	Foreign particle	Point-like	$0.25\text{mm} < \varphi$	N=0
			$0.20\text{mm} < \varphi \leq 0.25\text{mm}$	$N \leq 2$
			$\varphi \leq 0.20\text{mm}$	Acceptable
	Liner	$3.0\text{mm} < \text{length and } 0.08\text{mm} < \text{width}$	N=0	
		$\text{length} \leq 3.0\text{mm}$ or $\text{width} \leq 0.08\text{mm}$	Acceptable	
Others		Use boundary sample for judgment when necessary		

$\varphi$ (mm): Average diameter = (major axis + minor axis)/2  
Permissible number: N

Table 1

Area	High bright dot	Low bright dot	Dark dot	Total	Criteria
A	0	2	2	3	Permissible distance between same color bright dots (includes neighboring dots): 3 mm or more Permissible distance between same color high bright dots (includes neighboring dots): 5 mm or more
B	2	4	4	6	
Total	2	4	4	7	

&lt;Landscape model&gt;

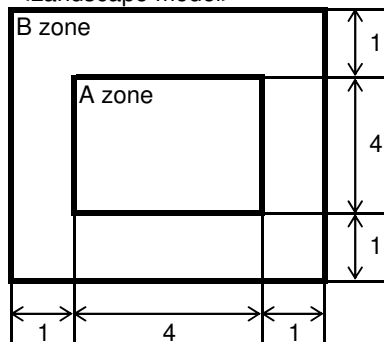

Division of A and B areas

B area: Active area

Dimensional ratio between A and B areas: 1: 4: 1

(Refer to the left figure)

Division of A and B areas







## 11. Reliability Test

Test item		Test condition		number of failures / number of examinations
Durability test	High temperature storage	Ta = 95°C	500hrs	0 / 3
	Low temperature storage	Ta = -40°C	500hrs	0 / 3
	High temperature & high humidity storage	Ta = 60°C, RH = 90%, non condensing	500hrs	0 / 3
	High temperature operation	Tp = 85°C	500hrs	0 / 3
	Low temperature operation	Tp = -30°C	500hrs	0 / 3
	High temperature & high humidity operation	Tp = 40°C, RH = 90%, non condensing	500hrs	0 / 3
	Thermal shock storage	-40°C ↔ 85°C (30min / 30min)	100cycles	0 / 3
	Lightfastness	Xenon Blackpanel 63±3°C non-shower 450W/m <sup>2</sup> (300~700nm) non-operating Integral dose 800MJ/m <sup>2</sup>		0 / 3
Mechanical environmental test	Electrostatic discharge test (Non operation)	Confirms to EIAJ ED-4701/300, C=200pF,R=0Ω,V=±200V Each 3 times of discharge on and power supply and other terminals.		0 / 3
	Surface discharge test (Non operation)	C=250pF, R=100Ω, V=±12kV Each 5 times of discharge in both polarities on the center of screen with the case grounded.		0 / 3
	FPC tension test	Pull the FPC with the force of 3N for 10 sec. in the direction - 90-degree to its original direction.		0 / 3
	FPC bend test	Pull the FPC with the force of 3N for 10 sec. in the direction -180-degree to its original direction. Reciprocate it 3 times.		0 / 3
	Vibration test (Non operation)	Use TOPPAN PRINTING original jig (see next page) Vibration Acceleration : 66.64 m/s <sup>2</sup> (6.8 G) Frequency : 20 ~ 500 Hz , Cycle : 10 min/sweep Orientation : X,Y,Z-directions 10 hours per direction (Total 30 hrs)		0 / 3
	Impact test (Non operation)	Use TOPPAN PRINTING original jig (see next page) and make an impact with peak acceleration of 1000m/s <sup>2</sup> for 6 msec with half sine-curve at 3 times to each X, Y, Z directions in conformance with JIS C 60068-2-27-2011.		0 / 3
Packing test	Packing vibration-proof test	Acceleration of 19.6m/s <sup>2</sup> with frequency of 10→55→10Hz, X,Y, Zdirection for each 30 minutes.		0 / 1 packing
	Packing drop test	Drop from 75cm high. 1 time to each 6 surfaces, 3 edges, 1 corner		0 / 1 packing

Note:Ta=ambient temperature Tp=Panel temperature

※ The profile of high temperature/humidity storage and High Temperature/humidity operation (Pure water of over 10MΩ·cm shall be used.)

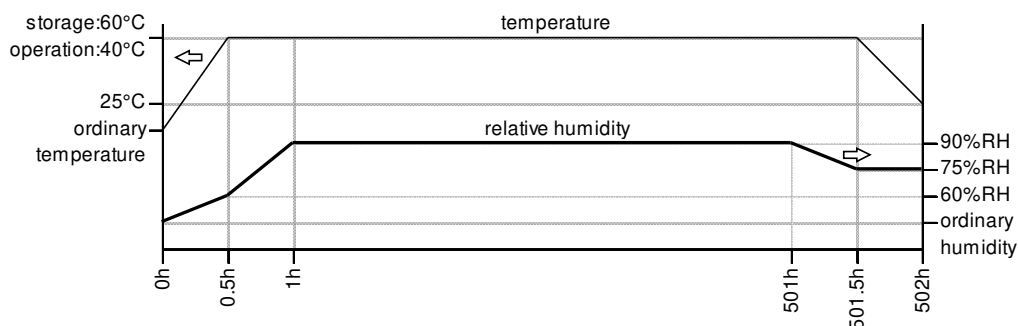
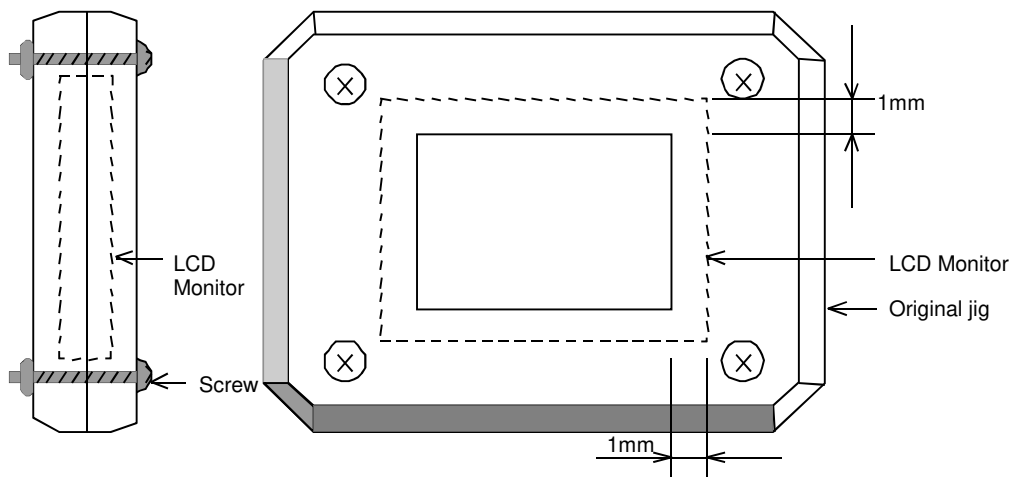

Table2.Reliability Criteria

The parameters should be measured after leaving the monitor at the ordinary temperature for 24 hours or more after the test completion.

item	Standard	Remarks
Display quality	No visible abnormality shall be seen. (Except for unevenness by Pol deterioration.)	
Contrast ratio	200 or more	Backlight ON

## TOPPAN PRINTING Original Jig



## Tension Test Method for FPC cable

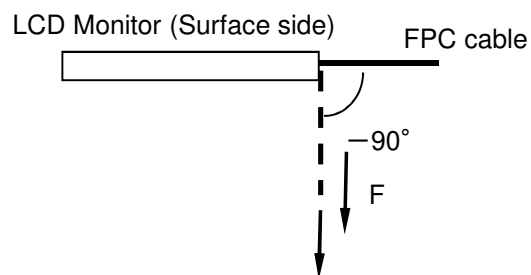

## Bend Test Method for FPC cable

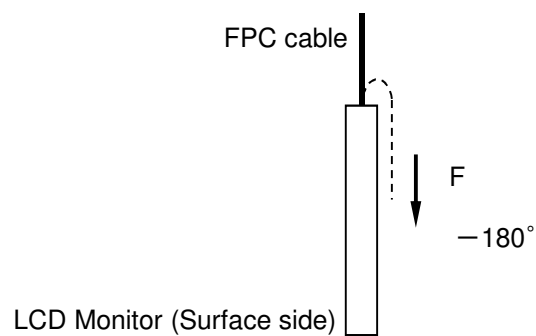

12. Packing Specifications

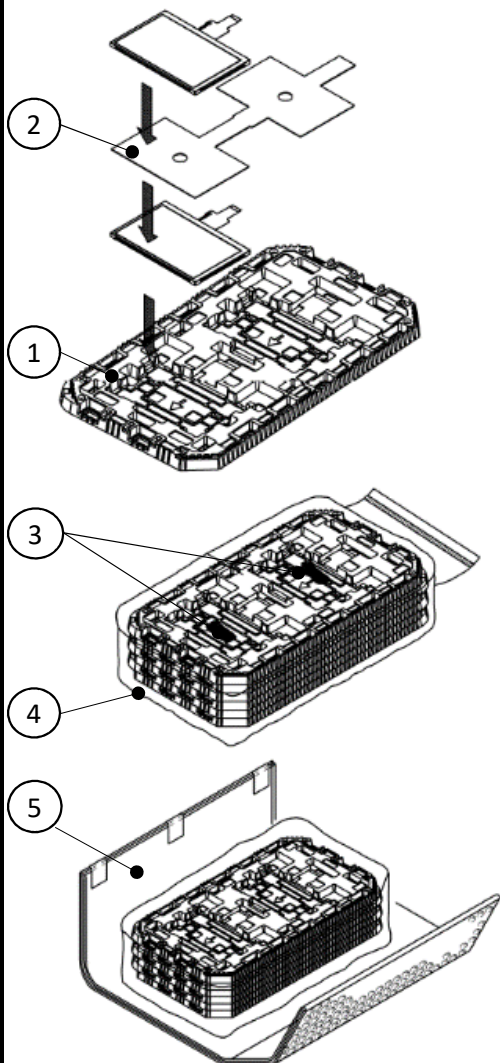

Step1. Each product is to be placed in one of the cut-outs of the tray with the display surface facing upward. (2products per tray)  
 Foam sheet is to be placed on the products in the tray.  
 Each product is to be placed in one of the cut-outs of the tray with the display surface facing upward.(4products per tray)

Step 2. The trays be in a stack of 5.(Rotate 180 degrees for each step)  
 One empty tray is to be put on the top of stack of 5 trays.

Step3. 2 packs of moisture absorbers are to be placed on the top tray as shown in the drawing. Put piled trays into a sealing bag.

Step4. Vacuum and seal the sealing bag with the vacuum sealing machine.

Step5. The stack of trays in the sealing bag is to be wrapped with a bubble cushioning sheet.

Step6. The wrapped trays are placed in the outer carton.

Step7. Bubble cushioning sheets are to be inserted into the outer carton with same orientation. The outer carton is to be sealed in H-shape with packing tape as shown in the drawing.

Step8. The model number, quantity of products, and shipping date are to be printed on the outer carton.  
 If necessary, shipping labels or impression markings are to be put on the outer carton.

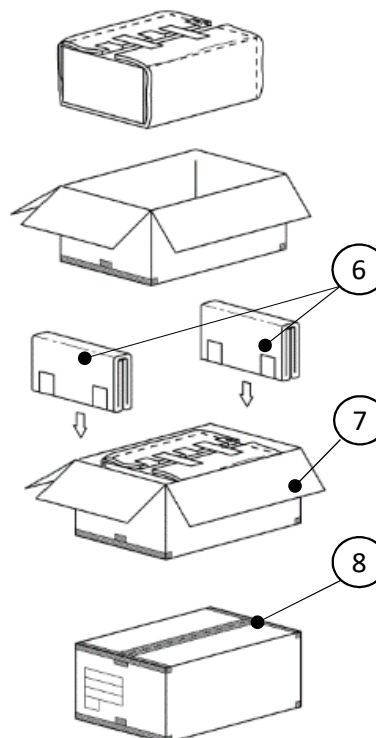

Remark: The return of packing materials is not required.

	Packing item name	Specs., Material
①	Tray	A-PET
②	Foam sheet	Anti-static polyethylene
③	Drier	Moisture absorber
④	Sealing bag	
⑤	B SHEET C	Antistatic air bubble sheet
⑥	B SHEET D	Antistatic air bubble sheet
⑦	Outer carton	Corrugated cardboard
⑧	Packing tape	

Dimension of outer carton	
D : Approx.	(356mm)
W : Approx.	(664mm)
H : Approx.	(182mm)
Quantity of products packed in one carton:	20
Gross weight : Approx.	4.6Kg

## 13. Handling Instruction

## 13.1 Cautions for Handling LCD panels

**Caution**

- (1) Do not make an impact on the LCD panel glass because it may break and you may get injured from it.
- (2) If the glass breaks, do not touch it with bare hands.  
(Fragment of broken glass may stick you or you cut yourself on it.)
- (3) If you get injured, receive adequate first aid and consult a medial doctor.
- (4) Do not let liquid crystal get into your mouth.  
(If the LCD panel glass breaks, try not let liquid crystal get into your mouth even toxic property of liquid crystal has not been confirmed.)
- (5) If liquid crystal adheres, rinse it out thoroughly.  
(If liquid crystal adheres to your cloth or skin, wipe it off with rubbing alcohol or wash it thoroughly with soap. If liquid crystal gets into eyes, rinse it with clean water for at least 15 minutes and consult an eye doctor.)
- (6) If you scrap this products, follow a disposal standard of industrial waste that is legally valid in the community, country or territory where you reside.
- (7) Do not connect or disconnect this product while its application products is powered on.
- (8) Do not attempt to disassemble or modify this product as it is precision component.
- (9) If a part of soldering part has been exposed, and avoid contact (short-circuit) with a metallic part of the case etc. about FPC of this model, please.  
Please insulate it with the insulating tape etc. if necessary.  
The defective operation is caused, and there is a possibility to generation of heat and the ignition.
- (10) Since excess current protection circuit is not built in this TFT module, there is the possibility that LCD module or peripheral circuit become feverish and burned in case abnormal operation is generated.  
We recommend you to add excess current protection circuit to power supply.
- (11) The devices on the FPC are damageable to electrostatic discharge, because the terminals of the devices are exposed.  
Wear grounded wrist-straps and use electrostatic neutralization blowers to prevent static charge and discharge when handling the TFT monitors.  
Designate an appropriate operating area, and set equipment, tools, and machines properly when handling this product.



**Caution** This mark is used to indicate a precaution or an instruction which, if not correctly observed, may result in bodily injury, or material damages alone.

### 13.2 Precautions for Handling

- 1) Wear finger tips at incoming inspection and for handling the TFT monitors to keep display quality and keep the working area clean.  
Do not touch the surface of the monitor as it is easily scratched.
- 2) Wear grounded wrist-straps and use electrostatic neutralization blowers to prevent static charge and discharge when handling the TFT monitors as the LED in this TFT monitors is damageable to electrostatic discharge. Designate an appropriate operating area, and set equipment, tools, and machines properly when handling this product.
- 3) Avoid strong mechanical shock including knocking, hitting or dropping to the TFT monitors for protecting their glass parts. Do not use the TFT monitors that have been experienced dropping or strong mechanical shock.
- 4) Do not use or storage the TFT monitors at high temperature and high humidity environment. Particularly, never use or storage the TFT monitors at a location where condensation builds up.
- 5) Avoid using and storing TFT monitors at a location where they are exposed to direct sunlight or ultraviolet rays to prevent the LCD panels from deterioration by ultraviolet rays.
- 6) Do not stain or damage the contacts of the FPC cable .  
FPC cable needs to be inserted until it can reach to the end of connector slot.  
During insertion, make sure to keep the cable in a horizontal position to avoid an oblique insertion.  
Otherwise, it may cause poor contact or deteriorate reliability of the FPC cable.
- 7) Do not bend or pull the FPC cable or carry the TFT monitor by holding the FPC cable.  
Especially, it will cause mechanical damage or critical defect if FPC is pull up or bent up to short of display.

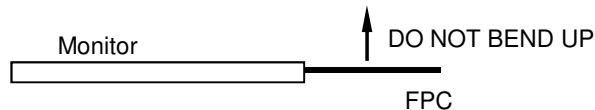

- 8) Peel off the protective film on the TFT monitors during mounting process.  
Refer to the section 13.5 on how to peel off the protective film.  
We are not responsible for electrostatic discharge failures or other defects occur when peeling off the protective film.

### 13.3 Precautions for Operation

- 1) Since this TFT monitors are not equipped with light shielding for the driver IC, do not expose the driver IC to strong lights during operation as it may cause functional failures.
- 2) In case of powering up or powering off this LCD module, be sure to comply the sequence as instructed in this specification.
- 3) Do not plug in or out the FPC cable while power supply is switch on.  
Plug the FPC cable in and out while power supply is switched off.
- 4) Do not operate the TFT monitors in the strong magnetic field. It may break the TFT monitors.
- 5) Do not display a fixed image on the screen for a long time.  
Use a screen-saver or other measures to avoid a fixed image displayed on the screen for a long time.  
Otherwise, it may cause burn-in image on the screen due the characteristics of liquid crystal.

### 13.4 Storage Condition for Shipping Cartons

#### Storage environment

- Temperature 0 to 40° C
- Humidity 60%RH or less  
No-condensing occurs under low temperature with high humidity condition.
- Atmosphere No poisonous gas that can erode electronic components and/or wiring materials should be detected.
- Time period 1 year
- Unpacking To prevent damages caused by static electricity, anti-static precautionary measures (e.g. earthing, anti-static mat) should be implemented.  
After unpack, keep product in the appropriate condition, otherwise bubble seal of Protective film may be printed on Polarizer.
- Maximum piling up 7 cartons

#### \*Conditions to storage after unpacking

#### Storage environment

- Temperature 0 to 40° C
- Humidity 60%RH or less  
No-condensing occurs under low temperature with high humidity condition.
- Atmosphere No poisonous gas that can erode electronic components and/or wiring materials should be detected.
- Time period 1 year (Shelf life)
- Others Keep/ store away from direct sunlight  
Storage goods on original tray made by TOPPAN PRINTING.

### 13.5 Precautions for Peeling off the Protective film

The followings work environment and work method are recommended to prevent the TFT monitors from static damage or adhesion of dust when peeling off the protective films.

#### A) Work Environment

- a) Humidity: 50 to 70 %RH, Temperature 15 to 27° C
- b) Operators should wear conductive shoes, conductive clothes, conductive finger tips and grounded wrist-straps.  
Use an electrostatic neutralization blower.  
Anti-static treatment should be implemented to work area's floor.
- c) Use a room shielded against outside dust with sticky floor mat laid at the entrance to eliminate dirt.

#### B) Work Method

The following procedures should taken to prevent the driver ICs from charging and discharging.

- a) Use an electrostatic neutralization blower to blow air on the TFT monitors to its lower left when FPC is placed at the bottom.  
Optimize direction of the blowing air and the distance between the TFT monitors and the electrostatic neutralization blower.
- b) Put an adhesive tape (Scotch tape, etc) at the lower left corner area of the protective film to prevent scratch on surface of TFT monitors.
- c) Peel off the adhesive tape slowly (spending more than 2 secs to complete) by pulling it to opposite direction.

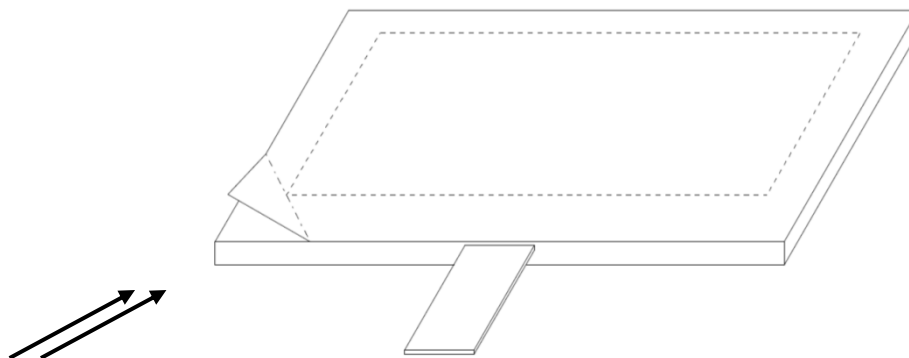

Blower wind direction (Set an ion blower with its adequate conditions.)

### 13.6 Warranty

TOPPAN PRINTING is only liable to defective goods which is stored and used under the condition complying with this specifications and returned within 1 (one) year.

Warranty caused by manufacturing defect shall be conducted by replacement of goods or refundment at unit price.

**APPENDIX**

Reference Method for Measuring Optical Characteristics and Performance

- ⚠ 1. Measurement Condition (Backlight ON)
- Measuring instruments: CS2000 (KONICA MINOLTA), LCD7200 (OTSUKA ELECTRONICS), EZcontrastXL88 (ELDIM)
- Driving condition: Refer to the section "Optical Characteristics"
- Measured temperature: 25°C unless specified
- Measurement system: See the chart below. The luminance meter is placed on the normal line of measurement system.
- Measurement point: At the center of the screen unless otherwise specified

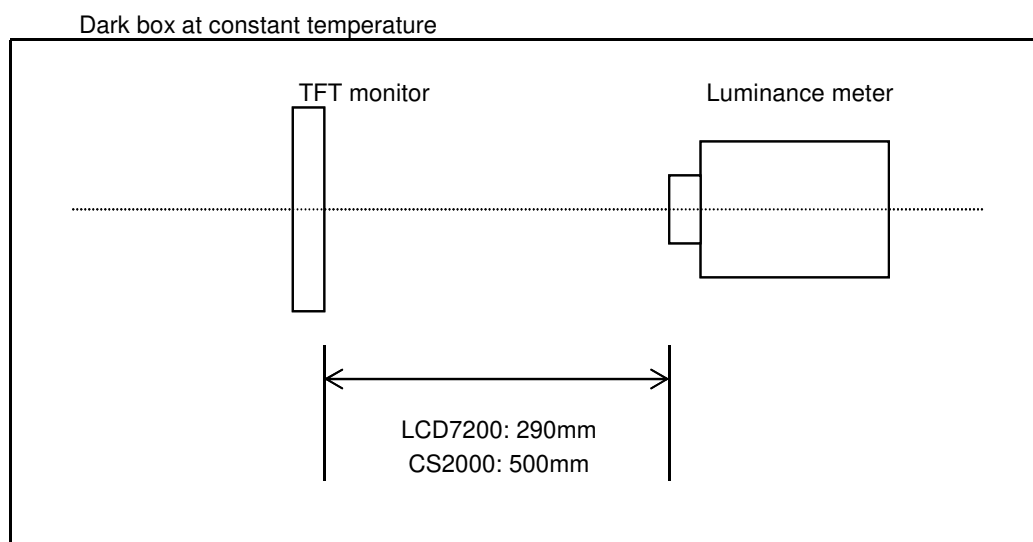

Measurement is made after 30 minutes of lighting of the backlight.

- Measurement point: At the center point of the screen
- Brightness distribution: 9 points shown in the following drawing.

<Landscape model>

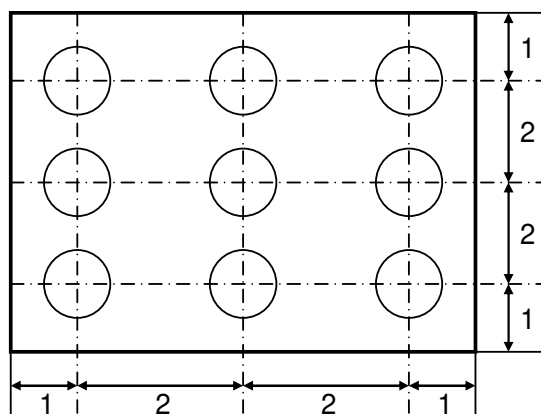

Dimensional ratio of active area

Backlight IL1=IL2=20mA



Measurement Condition (Contrast ratio Backlight OFF only)

Measuring instruments: LCD7200(OTSUKA ELECTRONICS),Ring Light(40,000 lx, $\phi$ 58)

Driving condition: Refer to the section "Optical Characteristics"

Measured temperature: 25° C unless specified

Measurement system: See the chart below.

Measurement point: At the center of the screen.

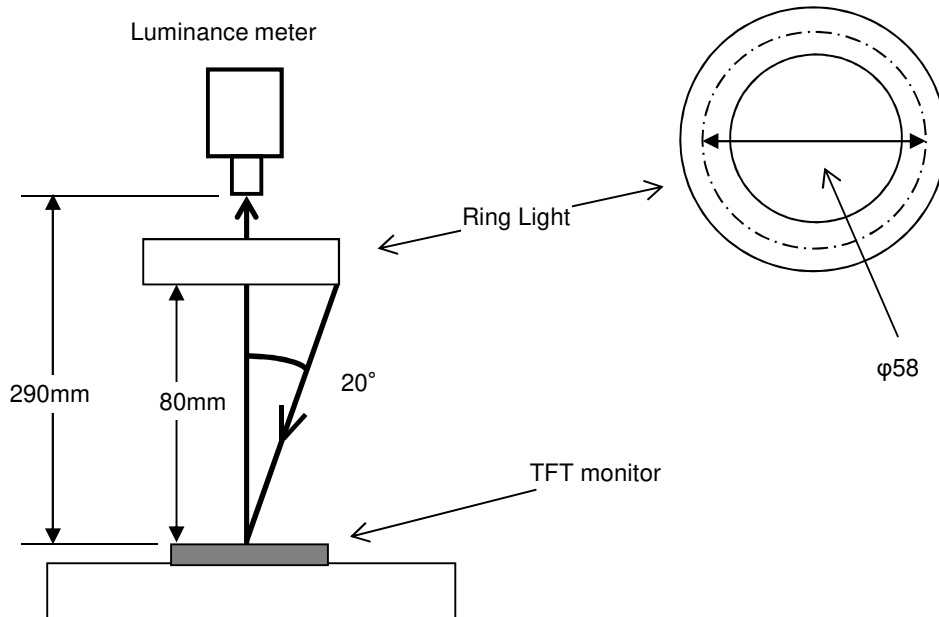



## 2. Test Method

Notice	Item	Test method	Measuring instrument	Remark
1	Response time	<p>Measure output signal waves with a brightness meter when the raster or window pattern is changed over from white to black and from black to white</p> <p style="text-align: center;">Black                      White                      Black</p> <p>White brightness</p> <p>100%</p> <p>90%</p> <p>10%</p> <p>0%</p> <p>Black brightness</p> <p>TON</p> <p>TOFF</p>	LCD7200	<p>Black display [Data]=00h</p> <p>White display [Data]=FFh</p> <p>TON</p> <p>Rise time</p> <p>TOFF</p> <p>Fall time</p>
2	Contrast ratio	<p>Measure maximum luminance <math>Y1</math> ([Data]=FFh) and minimum luminance <math>Y2</math> ([Data]=00h) at the center of the screen by displaying raster or window pattern. Then calculate the ratio between these two values.</p> <p>Contrast ratio = <math>Y1/Y2</math></p> <p>Diameter of measuring point: 7.8mm<math>\phi</math>(CS2000)</p> <p>Diameter of measuring point: 3mm<math>\phi</math>(LCD7200)</p>	CS2000 LCD7200	Backlight ON Backlight OFF
3	Viewing angle Horizontal $\theta$ Vertical $\phi$	Move the luminance meter from right to left and up and down and determine the angles where contrast ratio is 10.	EZcontrastXL88	
4	White chromaticity	<p>Measure chromaticity coordinates <math>x</math> and <math>y</math> of CIE1931 colorimetric system at [Data] = FFh</p> <p>Color matching function: 2°view</p> <p>Measurement angle: 1°</p>	CS2000	
5	Burn-in	Visually check burn-in image on the screen after 2 hours of "window display" ([Data]=00h/FFh).		At optimized VCOMDC
6	Center brightness	Measure the brightness at the center of the screen.	CS2000	
7	Brightness distribution	<p>(Brightness distribution) = <math>100 \times B/A \%</math></p> <p>A : max. brightness of the 9 points</p> <p>B : min. brightness of the 9 points</p>	CS2000	

Our company network supports you worldwide with offices in Germany, Austria, Switzerland, the UK and the USA. For more information please contact:

## Headquarters

### Germany



#### FORTEC Elektronik AG

Augsburger Str. 2b  
82110 Germering

Phone: +49 89 894450-0  
E-Mail: [info@forteca.de](mailto:info@forteca.de)  
Internet: [www.forteca.de](http://www.forteca.de)

## Fortec Group Members

### Austria



#### Distec GmbH Office Vienna

Nuschinggasse 12  
1230 Wien

Phone: +43 1 8673492-0  
E-Mail: [info@distec.de](mailto:info@distec.de)  
Internet: [www.distec.de](http://www.distec.de)

### Germany



#### Distec GmbH

Augsburger Str. 2b  
82110 Germering

Phone: +49 89 894363-0  
E-Mail: [info@distec.de](mailto:info@distec.de)  
Internet: [www.distec.de](http://www.distec.de)

### Switzerland



#### ALTRAC AG

Bahnhofstraße 3  
5436 Würenlos

Phone: +41 44 7446111  
E-Mail: [info@altrac.ch](mailto:info@altrac.ch)  
Internet: [www.altrac.ch](http://www.altrac.ch)

### United Kingdom



#### Display Technology Ltd.

Osprey House, 1 Osprey Court  
Hichingbrooke Business Park  
Huntingdon, Cambridgeshire, PE29 6FN

Phone: +44 1480 411600  
E-Mail: [info@displaytechnology.co.uk](mailto:info@displaytechnology.co.uk)  
Internet: [www.displaytechnology.co.uk](http://www.displaytechnology.co.uk)

### USA



#### Apollo Display Technologies, Corp.

87 Raynor Avenue,  
Unit 1 Ronkonkoma,  
NY 11779

Phone: +1 631 5804360  
E-Mail: [info@apolloDisplays.com](mailto:info@apolloDisplays.com)  
Internet: [www.apolloDisplays.com](http://www.apolloDisplays.com)