



OUR GLOBAL
COMPETENCE
CENTRES

 APOLLO DISPLAY
TECHNOLOGIES



 DISTEC



 DISPLAY
TECHNOLOGY



Datasheet

Tianma

NL10276AC30-53D

15.0" TFT Display

NL-01-023

TFT COLOR LCD MODULE

NL10276AC30-53D

38cm (15.0 Type)

XGA

LVDS interface (1port)

DATA SHEET

DOD-PP-3601 (1st edition)



**This DATA SHEET is updated document from
PRELIMINARY DATA SHEET DOD-PP-2649(3)**

**All information is subject to change without notice.
Please confirm the sales representative before
starting to design your system.**

INTRODUCTION

The Copyright to this document belongs to Tianma Japan, Ltd. (hereinafter called "TMJ"). No part of this document will be used, reproduced or copied without prior written consent of TMJ.

TMJ does and will not assume any liability for infringement of patents, copyrights or other intellectual property rights of any third party arising out of or in connection with application of the products described herein except for that directly attributable to mechanisms and workmanship thereof. No license, express or implied, is granted under any patent, copyright or other intellectual property right of TMJ.

Some electronic products would fail or malfunction at a certain rate. In spite of every effort to enhance reliability of products by TMJ, the possibility of failures and malfunction might not be avoided entirely. To prevent the risks of damage to death, human bodily injury or other property arising out thereof or in connection therewith, each customer is required to take sufficient measures in its safety designs and plans including, but not limited to, redundant system, fire-containment and anti-failure.

The products are classified into three grades: "**Standard**", "**Special**", and "**Specific**".

Each quality grade is designed for applications described below. Any customer who intends to use a product for application other than that of Standard is required to contact TMJ sales representative in advance.

The **Standard**: Applications as any failure, malfunction or error of the products are free from any damage to death, human bodily injury or other property (Products Safety Issue) and not related the safety of the public (Social Issues), like general electric devices.

Examples: Office equipment, audio and visual equipment, communication equipment, test and measurement equipment, personal electronic equipment, home electronic appliances, car navigation system (with no vehicle control functions), seat entertainment monitor for vehicles and airplanes, fish finder (except marine radar integrated type), PDA, etc.

The **Special**: Applications as any failure, malfunction or error of the products might directly cause any damage to death, human bodily injury or other property (Products Safety Issue) and the safety of the public (Social Issues) and required high level reliability by conventional wisdom.

Examples: Vehicle/train/ship control system, traffic signals system, traffic information control system, air traffic control system, surgery/operation equipment monitor, disaster/crime prevention system, etc.

The **Specific**: Applications as any failure, malfunction or error of the products might severe cause any damage to death, human bodily injury or other property (Products Safety Issue) and the safety of the public (Social Issues) and developed, designed and manufactured in accordance with the standards or quality assurance program designated by the customer who requires extremely high level reliability and quality.

Examples: Aerospace system (except seat entertainment monitor), nuclear control system, life support system, etc.

The quality grade of this product is the "**Standard**" unless otherwise specified in this document.

CONTENTS

INTRODUCTION	2
1. OUTLINE.....	4
1.1 STRUCTURE AND PRINCIPLE	4
1.2 APPLICATION	4
1.3 FEATURES	4
2. GENERAL SPECIFICATIONS.....	5
3. BLOCK DIAGRAM.....	6
4. DETAILED SPECIFICATIONS.....	7
4.1 MECHANICAL SPECIFICATIONS	7
4.2 ABSOLUTE MAXIMUM RATINGS.....	7
4.3 ELECTRICAL CHARACTERISTICS.....	8
4.3.1 LCD panel signal processing board.....	8
4.3.2 LED driver	9
4.3.3 Fuse.....	10
4.4 POWER SUPPLY VOLTAGE SEQUENCE.....	10
4.4.1 LCD panel signal processing board.....	10
4.4.2 LED driver	11
4.5 CONNECTIONS AND FUNCTIONS FOR INTERFACE PINS.....	12
4.5.1 LCD panel signal processing board.....	12
4.5.2 Position of socket.....	13
4.5.3 Input data mapping	14
4.6 DISPLAY COLORS AND INPUT DATA SIGNALS.....	15
4.6.1 Combinations of input data signals and FRC signal.....	15
4.6.2 16,194,277 colors.....	16
4.6.3 262,144 colors.....	17
4.7 DISPLAY POSITIONS	18
4.8 SCANNING DIRECTIONS	18
4.9 INPUT SIGNAL TIMINGS	19
4.9.1 Outline of input signal timings	19
4.9.2 Timing characteristics.....	20
4.9.3 Input signal timing chart.....	21
4.10 LVDS Rx AC SPEC	22
4.11 OPTICS.....	23
4.11.1 Optical characteristics	23
4.11.2 Definition of contrast ratio.....	24
4.11.3 Definition of luminance uniformity	24
4.11.4 Definition of response times	24
4.11.5 Definition of viewing angles.....	24
5. ESTIMATED LUMINANCE LIFETIME.....	25
6. RELIABILITY TESTS	26
7. PRECAUTIONS	27
7.1 MEANING OF CAUTION SIGNS	27
7.2 CAUTIONS	27
7.3 ATTENTIONS.....	27
7.3.1 Handling of the product	27
7.3.2 Environment.....	28
7.3.3 Characteristics.....	28
7.3.4 Others.....	28
8. OUTLINE DRAWINGS.....	29
8.1 FRONT VIEW	29
8.2 REAR VIEW	30

1. OUTLINE

1.1 STRUCTURE AND PRINCIPLE

Color LCD module NL10276AC30-53D is composed of the amorphous silicon thin film transistor liquid crystal display (a-Si TFT LCD) panel structure with driver LSIs for driving the TFT (Thin Film Transistor) array and a backlight.

The a-Si TFT LCD panel structure is injected liquid crystal material into a narrow gap between the TFT array glass substrate and a color-filter glass substrate.

Color (Red, Green, Blue) data signals from a host system (e.g. signal generator, etc.) are modulated into best form for active matrix system by a signal processing board, and sent to the driver LSIs which drive the individual TFT arrays.

The TFT array as an electro-optical switch regulates the amount of transmitted light from the backlight assembly, when it is controlled by data signals. Color images are created by regulating the amount of transmitted light through the TFT array of red, green and blue dots.

1.2 APPLICATION

- For industrial use

1.3 FEATURES

- Wide viewing angle
- LVDS interface ☆
- Selectable 8-bit or 6-bit digital signals for data of RGB
- Reversible-scan direction
- Narrow border
- Thin structure
- LED backlight built in LED driver
- Replaceable lamp for backlight
- Acquisition product for UL60950-1/CSA C22.2 No.60950-1-03 (File number: E170632) ☆
- Compliant with the European RoHS directive (2011/65/EU) ☆

2. GENERAL SPECIFICATIONS

Display area	304.128 (H) × 228.096 (V) mm	
Diagonal size of display	38cm (15.0 inches)	
Drive system	a-Si TFT active matrix	
Display color	16,194,277 colors (At 8-bit input, FRC terminal= High or Open) 262,144 colors (At 6-bit input, FRC terminal= Low)	☆
Pixel	1,024 (H) × 768 (V) pixels	
Pixel arrangement	BGR (Blue dot, Green dot, Red dot) vertical stripe	
Dot pitch	0.099 (H) × 0.297 (V) mm	
Pixel pitch	0.297 (H) × 0.297 (V) mm	
Module size	326.5 (W) × 253.5 (H) × 6.3 (D) mm (typ.)	
Weight	640g (typ.)	
Contrast ratio	1,000:1 (typ.)	
Viewing angle	At the contrast ratio ≥10:1 <ul style="list-style-type: none"> • Horizontal: Right side 80° (typ.), Left side 80° (typ.) • Vertical: Up side 80° (typ.), Down side 80° (typ.) 	
Designed viewing direction	At DPS = Low or Open: Normal scan <ul style="list-style-type: none"> • Viewing direction without image reversal: Up side (12 o'clock) • Viewing direction with contrast peak: Down side (6 o'clock) • Viewing angle with optimum grayscale ($\gamma=2.2$): Normal axis (perpendicular) 	
Polarizer surface	Antiglare	
Polarizer pencil-hardness	3H (min.) [by JIS K5600]	
Color gamut	At LCD panel center 60% (typ.) [against NTSC color space]	
Response time	$T_{on}+T_{off}$ (10%←→90%) 8ms (typ.)	
Luminance	At the maximum luminance control 500cd/m ² (typ.)	
Signal system	LVDS interface (1 port) [8-bit/6-bit digital signals for data of RGB colors, Dot clock (CLK), Data enable (DE)]	☆
Power supply voltage	LCD panel signal processing board: 3.3V LED driver: 12.0V	
Backlight	LED backlight built in LED driver (Replaceable part • Lamp holder set: 150LHS207)	☆
Power consumption	At the maximum luminance control, Checkered flag pattern 8.5W (typ.)	

3. BLOCK DIAGRAM

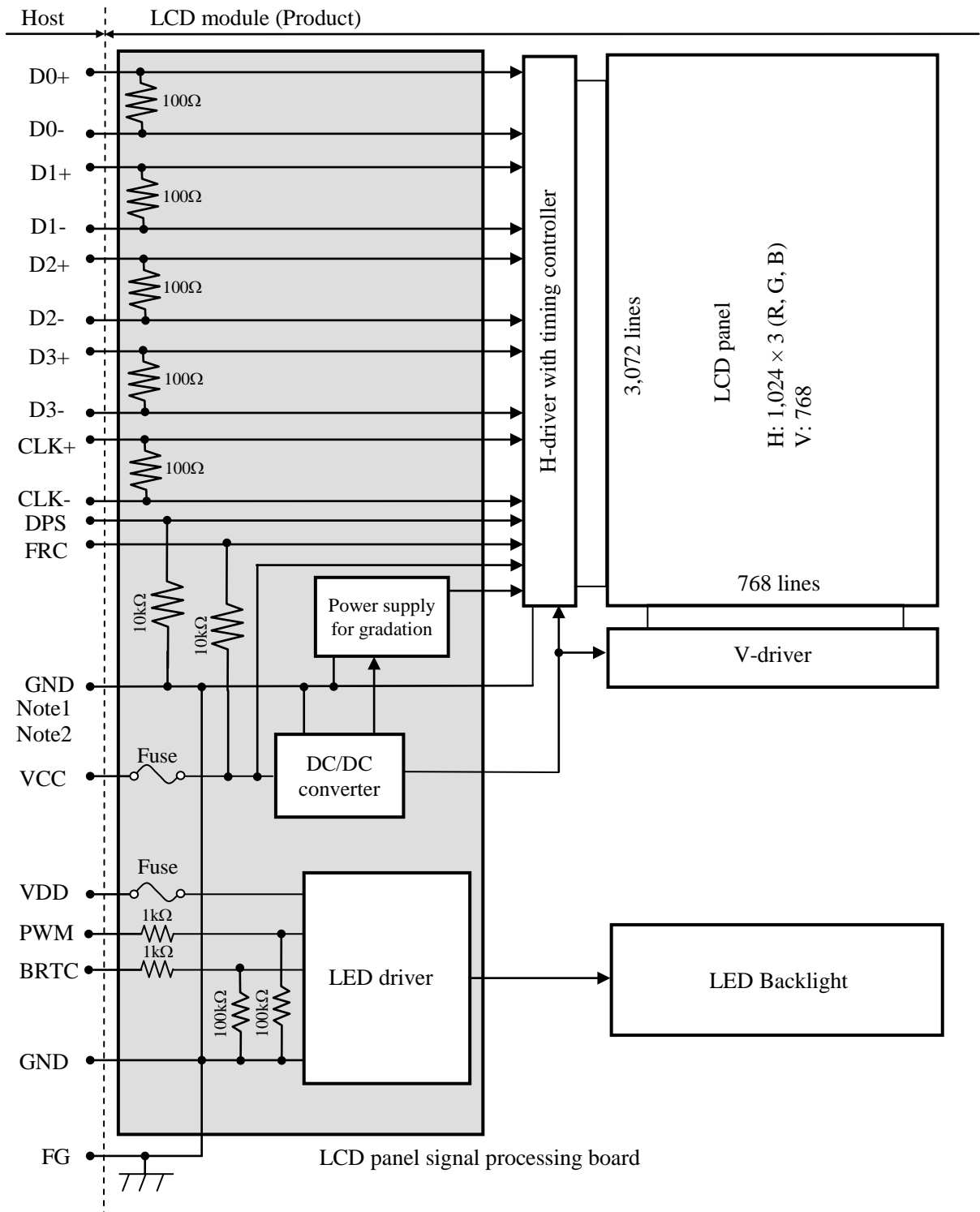

Note1: Relation between GND (Signal ground and LED driver ground) and FG (Frame ground) in the LCD module is as follows.

GND- FG	Connected
---------	-----------

Note2: GND and FG must be connected to customer equipment's ground, and it is recommended that these grounds to be connected together in customer equipment.

4. DETAILED SPECIFICATIONS
4.1 MECHANICAL SPECIFICATIONS

Parameter	Specification	Unit
Module size	326.5 ± 0.5 (W) × 253.5 ± 0.5 (H) × 6.3 ± 0.5 (D) Note1 Note2	mm
Display area	304.128 (H) × 228.096 (V) Note1	mm
Weight	640 (typ.), 700 (max.)	g

Note1: See "8. OUTLINE DRAWINGS".

Note2: Excluding a bulge of the FPC

4.2 ABSOLUTE MAXIMUM RATINGS

Parameter		Symbol	Rating	Unit	Remarks	
Power supply voltage	LCD panel signal processing board	VCC	-0.3 to +4.0	V	Ta = 25°C	
	LED driver	VDD	-0.3 to +15.0	V		
Input voltage for signals	LCD panel signal processing board	Display signals Note1	VD	-0.3 to +4.0		V
		Function signals Note2	VF	-0.3 to +4.0		V
	LED driver		PWM	-0.3 to +5.5		V
			BRTC	-0.3 to +VDD		V
Storage temperature		Tst	-20 to +70	°C		-
Operating temperature		Front surface	TopF	-20 to +70		°C
		Rear surface	TopR	-20 to +70	°C	Note4
Relative humidity Note5		RH	≤ 95	%	Ta ≤ 40°C	
			≤ 85	%	40°C < Ta ≤ 50°C	
			≤ 55	%	50°C < Ta ≤ 60°C	
			≤ 36	%	60°C < Ta ≤ 70°C	
Absolute humidity Note5		AH	≤ 70 Note6	g/m ³	Ta = 70°C	

Note1: D0+/-, D1+/-, D2+/-, D3+/-, CLK+/-

Note2: DPS, FRC

Note3: Measured at LCD panel surface (including self-heat)

Note4: Measured at LCD module's rear shield surface (including self-heat)

Note5: No condensation

Note6: Water amount at Ta = 70°C and RH = 36%

4.3 ELECTRICAL CHARACTERISTICS

4.3.1 LCD panel signal processing board

(Ta= 25°C, Note1)

Parameter	Symbol	min.	typ.	max.	Unit	Remarks
Power supply voltage	VCC	3.0	3.3	3.6	V	-
Power supply current	ICC	-	400 Note2	780 Note3	mA	at VCC= 3.3V
Permissible ripple voltage	VRPC	-	-	100	mVp-p	for VCC Note4, Note5, Note6
Differential input threshold voltage	High	VTH	-	+100	mV	at VCM= 1.2V Note7, Note8
	Low	VTL	-100	-	mV	
Input Differential Voltage	VID	200	-	600	mV	-
Differential Input Common Mode Voltage	VCM	0.9	1.2	1.5	V	-
Terminating resistance	RT	-	100	-	Ω	-
Input voltage for DPS signal	High	VFH1	0.7VCC	-	VCC	CMOS level
	Low	VFL1	0	-	0.3VCC	
Input voltage for FRC signal	High	VFH2	0.7VCC	-	VCC	
	Low	VFL2	0	-	0.3VCC	
Input current for DPS signal	High	IFH1	-	+500	μA	-
	Low	IFL1	-500	-	μA	
Input current for FRC signal	High	IFH2	-	+500	μA	
	Low	IFL2	-500	-	μA	

Note1: When designing of the power supply, take the measures for the prevention of surge voltage.

Note2: Checkered flag pattern [by IEC 61747-6]

Note3: Pattern for maximum current

Note4: This product works even if the ripple voltage levels are over the permissible values, but there might be noise on the display image.

Note5: The permissible ripple voltage includes spike noise.

Note6: The load variation influence does not include.

Note7: Common mode voltage for LVDS receiver

Note8: DC characteristics (LVDS receiver part)

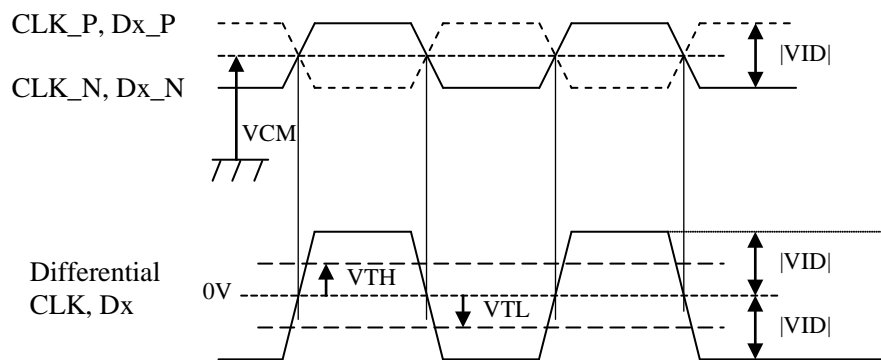

CLK_P, CLK_N
 Dx_P, Dx_N: x = 0,1,2,3
 $|VID| = |**_P_**_N|$
 $VCM = (**_P+**_N)/2$
 P: +, N: -
 **: CLK or Dx

4.3.2 LED driver

(Ta= 25°C, Note1)

Parameter	Symbol	min.	typ.	max.	Unit	Remarks	
Power supply voltage	VDD	10.8	12.0	13.2	V	-	
Power supply current	IDD	-	600	680 Note2	mA	at VDD= 12.0V, at the maximum luminance control	
Permissible ripple voltage	VRPD	-	-	200	mVp-p	for VDD Note3, Note4, Note5	
Input voltage for function signal	PWM	High	VDFH1	2.1	-	5.3	Note6
		Low	VDFL1	0	-	0.4	
	BRTC	High	VDFH2	2.1	-	VDD	
		Low	VDFL2	0	-	0.4	
PWM frequency	f _{PWM}	200	-	10k	Hz	Note7, Note8	
PWM duty ratio	DR _{PWM}	1	-	100	%	Note9, Note10, Note11	
PWM pulse width	tPWH	5	-	-	μs		

Note1: When designing of the power supply, take the measures for the prevention of surge voltage.

Note2: This value excludes peak current such as overshoot current.

Note3: This product works even if the ripple voltage levels are over the permissible values, but there might be noise on the display image.

Note4: The permissible ripple voltage includes spike noise.

Note5: The power supply lines (VDD and GND) may have ripple voltage during luminance control of LED. There is the possibility that the ripple voltage produces acoustic noise and signal wave noise in audio circuit and so on.

Note6: See "**3. BLOCK DIAGRAM**".

Note7: A recommended f_{PWM} value is as follows.

$$f_{\text{PWM}} = \frac{2n - 1}{4} \times f_v$$

(n = integer, f_v = frame frequency of LCD module)

Note8: Depending on the frequency used, some noise may appear on the screen, please conduct a thorough evaluation.

Note9: $DR_{\text{PWM}} = \frac{t\text{PWH}}{t\text{PW}}$

tPWH: PWM pulse width, tPW: PWM dimming cycle (= 1/f_{PWM})

Note10: While the BRTC signal is high, do not set the tPWH (PWM pulse width) is less than minimum value. It may cause abnormal working of the backlight. In this case, turn the backlight OFF and then ON again by BRTC signal.

Note11: Regardless of the PWM frequency, both PWM duty ratio and PWM pulse width must be always more than the minimum values.

4.3.3 Fuse

Parameter	Fuse		Rating	Fusing current	Remarks
	Type	Supplier			
VCC	FCC16152AB	KAMAYA ELECTRIC Co., Ltd.	1.5A	3.0A 5 seconds maximum	Note1
			36V		
VDD	FCC16202AB	KAMAYA ELECTRIC Co., Ltd.	2.0A	4.0A, 5 seconds maximum	
			36V		

Note1: The power supply's rated current must be more than the fusing current. If it is less than the fusing current, the fuse may not blow in a short time, and then nasty smell, smoke and so on may occur.

4.4 POWER SUPPLY VOLTAGE SEQUENCE

4.4.1 LCD panel signal processing board

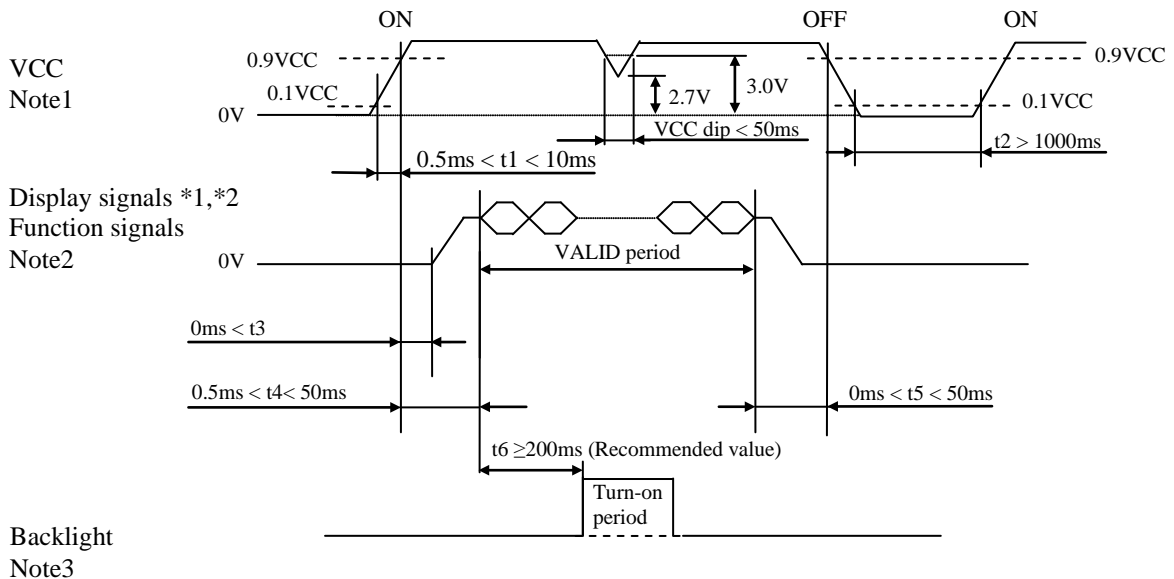

* D0+/-, D1+/-, D2+/-, D3+/-, CLK+/-
 * These signals should be measured at the terminal of 100Ω resistance.

Note1: If there is a voltage variation (voltage drop) at the rising edge of VCC below 3.0V, there is a possibility that a product does not work due to a protection circuit.

Note2: Display signals (D0+/-, D1+/-, D2+/-, D3+/- and CLK+/-) and function signals (DPS and FRC) must be set to Low or High-impedance, except the VALID period (See above sequence diagram), in order to avoid the circuitry damage.

If some of display and function signals of this product are cut while this product is working, even if the signal input to it once again, it might not work normally. If a customer stops the display and function signals, VCC also must be shut down.

Note3: In order to avoid unstable data display, the backlight is recommended to turn on within the VALID period of display and function signals.

Recommended value: $t6 \geq 200ms$

4.4.2 LED driver

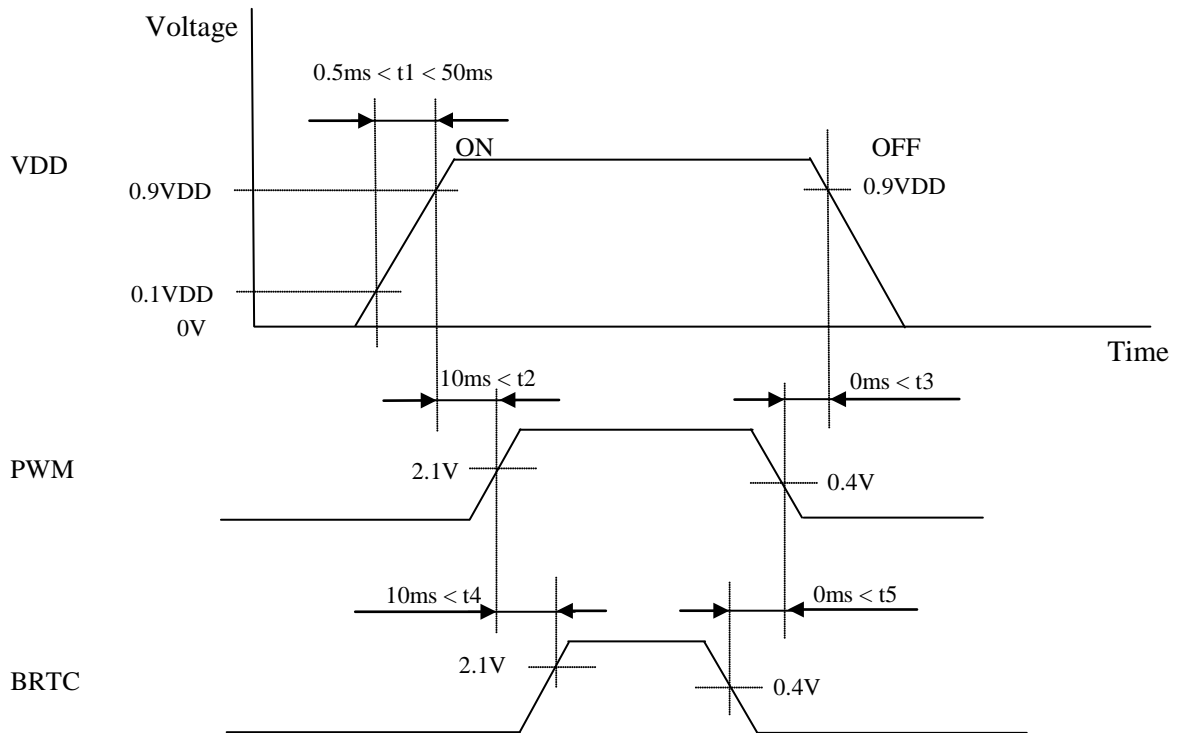

4.5 CONNECTIONS AND FUNCTIONS FOR INTERFACE PINS
4.5.1 LCD panel signal processing board

CN1 socket (LCD module side): MSCK2407P30 (STM)

Adaptable plug: FI-X30H (Japan Aviation Electronics Industry Limited (JAE))

☆

Pin No.	Symbol	Signal	Input data signal: 8-bit	Input data signal: 6-bit	Remarks
1	VCC	Power supply	Power supply		Note1
2	VCC				
3	GND	Ground	Ground		Note1
4	DPS	Selection of scan direction	High: Low or Open:	Reverse scan Normal scan	Note2
5	D0-	Pixel data	R0-R5, G0		Note3
6	D0+				
7	GND	Ground	Ground		Note1
8	D1-	Pixel data	G1-G5, B0-B1		Note3
9	D1+				
10	GND	Ground	Ground		Note1
11	D2-	Pixel data	B2-B5, DE		Note3
12	D2+				
13	GND	Ground	Ground		Note1
14	CLK-	Pixel clock	Pixel clock		Note3
15	CLK+				
16	GND	Ground	Ground		Note1
17	D3- / GND	Pixel data / Ground	R6-R7 G6-G7 B6-B7	Ground	Note3
18	D3+ / GND				
19	N.C.	Non connection	Keep this pin Open		-
20	FRC	Selection of the number of colors	High or Open	Low	Note4
21	N.C.	Non connection	Keep this pin Open		-
22	BRTC	Backlight ON/OFF control	High: Low or Open:	ON OFF	-
23	PWM	Luminance control	PWM dimming		-
24	GND	Ground	Ground		Note1
25	GND	Ground	Ground		Note1
26	VDD	Power supply for LED driver	Power supply LED driver		Note1
27	VDD				
28	VDD				
29	VDD				
30	GND	Ground	Ground		Note1

Note1: All GND, VCC and VDD terminals should be used without any non-connected lines.

 Note2: See "**4.8 SCANNING DIRECTIONS**".

Note3: Twist pair wires with 100Ω (Characteristic impedance) should be used between LCD panel signal processing board and LVDS transmitter.

 Note4: See "**4.6 DISPLAY COLORS AND INPUT DATA SIGNALS**".

☆

4.5.2 Position of socket

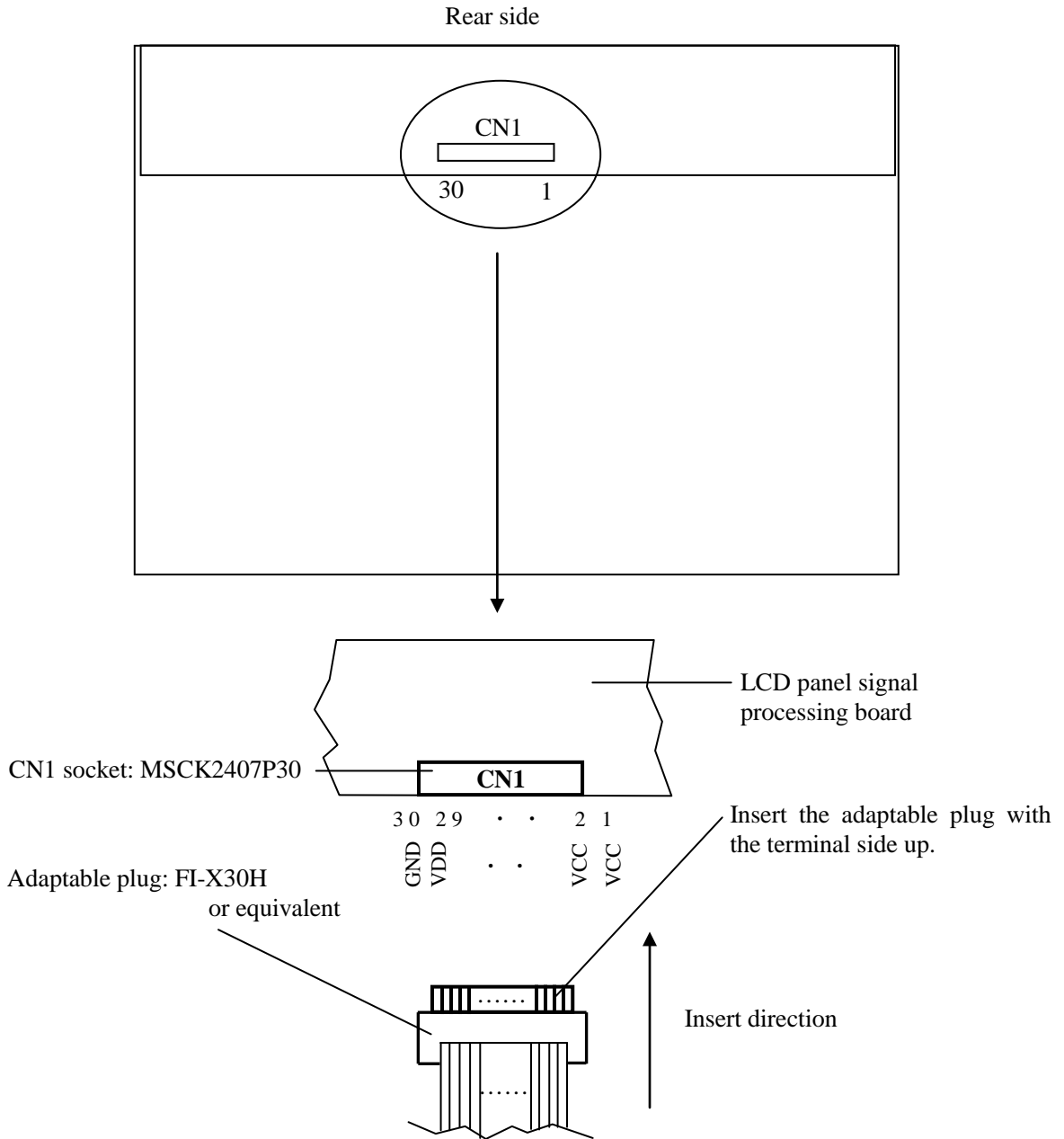

4.5.3 Input data mapping

(1) Input data signal: 8-bit

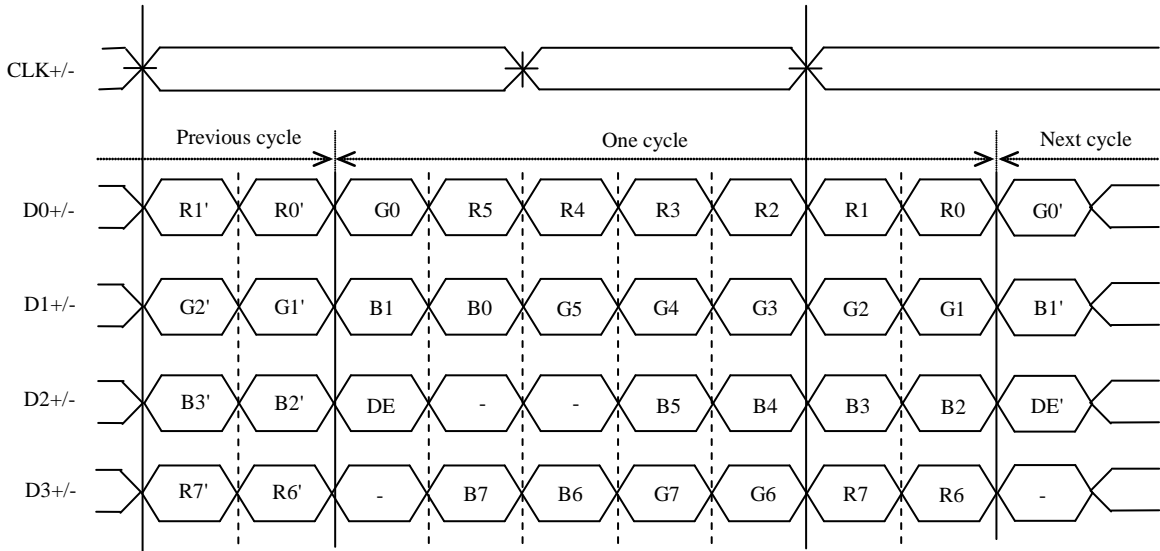

Note1: LSB (Least Significant Bit) – R0, G0, B0 MSB (Most Significant Bit) – R7, G7, B7

Note2: Twist pair wires with 100Ω(Characteristic impedance) should be used between LCD panel signal processing board and LVDS transmitter.

(2) Input data signal: 6-bit

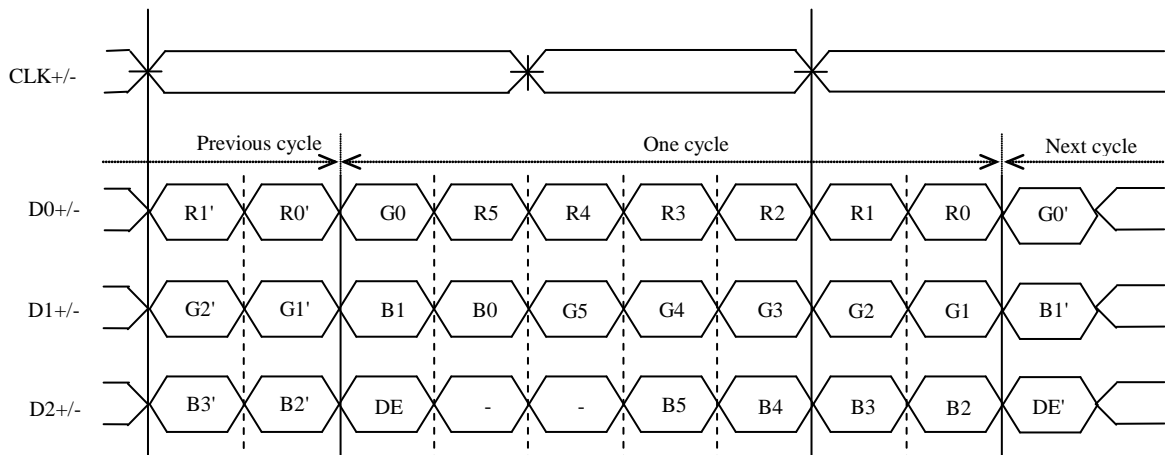

Note1: LSB (Least Significant Bit) – R0, G0, B0 MSB (Most Significant Bit) – R5, G5, B5

Note2: Twist pair wires with 100Ω(Characteristic impedance) should be used between LCD panel signal processing board and LVDS transmitter.

4.6 DISPLAY COLORS AND INPUT DATA SIGNALS

4.6.1 Combinations of input data signals and FRC signal

This product can display equivalent of 16,194,277 colors and 262,144 colors by combination of input data signals and FRC signal. See the following table.

Combination	Input data signals	CN1- Pin No.17 and 18	FRC terminal	Display colors	Remarks
①	8-bit	D3+/-	High or Open	16,194,277	Note1
②	6-bit	GND	Low	262,144	Note2

Note1: See "**4.6.2 16,194,277 colors**".

Note2: See "**4.6.3 262,144 colors**".

4.6.2 16,194,277 colors

This product can display equivalent of 16,194,277 colors with 253 gray scales by combination ①.
(See "4.6.1 Combinations of input data signals and FRC signal".)

Also the relation between display colors and input data signals is as follows.

(Note1)

Display colors		Data signal (0: Low level, 1: High level)																							
		R7	R6	R5	R4	R3	R2	R1	R0	G7	G6	G5	G4	G3	G2	G1	G0	B7	B6	B5	B4	B3	B2	B1	B0
Basic Colors	Black	0	0	0	0	0	0	0	0	0	0	0	0	0	0	0	0	0	0	0	0	0	0	0	0
	Blue	0	0	0	0	0	0	0	0	0	0	0	0	0	0	0	0	1	1	1	1	1	1	x	x
	Red	1	1	1	1	1	1	x	x	0	0	0	0	0	0	0	0	0	0	0	0	0	0	0	0
	Magenta	1	1	1	1	1	1	x	x	0	0	0	0	0	0	0	0	1	1	1	1	1	1	x	x
	Green	0	0	0	0	0	0	0	0	1	1	1	1	1	1	x	x	0	0	0	0	0	0	0	0
	Cyan	0	0	0	0	0	0	0	0	1	1	1	1	1	1	x	x	1	1	1	1	1	1	x	x
	Yellow	1	1	1	1	1	1	x	x	1	1	1	1	1	1	x	x	0	0	0	0	0	0	0	0
	White	1	1	1	1	1	1	x	x	1	1	1	1	1	1	x	x	1	1	1	1	1	1	x	x
Red gray scale	Black	0	0	0	0	0	0	0	0	0	0	0	0	0	0	0	0	0	0	0	0	0	0	0	
	dark	0	0	0	0	0	0	1	0	0	0	0	0	0	0	0	0	0	0	0	0	0	0	0	
	↑				:							:							:						
	↓				:							:							:						
	bright	1	1	1	1	1	0	1	0	0	0	0	0	0	0	0	0	0	0	0	0	0	0	0	
Red	1	1	1	1	1	0	1	0	0	0	0	0	0	0	0	0	0	0	0	0	0	0	0		
	Red	1	1	1	1	1	x	0	0	0	0	0	0	0	0	0	0	0	0	0	0	0	0		
Green gray scale	Black	0	0	0	0	0	0	0	0	0	0	0	0	0	0	0	0	0	0	0	0	0	0	0	
	dark	0	0	0	0	0	0	0	0	0	0	0	0	0	0	1	0	0	0	0	0	0	0	0	
	↑				:							:							:						
	↓				:							:							:						
	bright	0	0	0	0	0	0	0	1	1	1	1	1	0	1	0	0	0	0	0	0	0	0	0	
Green	0	0	0	0	0	0	0	1	1	1	1	1	0	1	1	0	0	0	0	0	0	0	0		
	Green	0	0	0	0	0	0	1	1	1	1	1	1	x	x	0	0	0	0	0	0	0	0		
Blue gray scale	Black	0	0	0	0	0	0	0	0	0	0	0	0	0	0	0	0	0	0	0	0	0	0	0	
	dark	0	0	0	0	0	0	0	0	0	0	0	0	0	0	0	0	0	0	0	0	0	0	1	
	↑				:							:							:						
	↓				:							:							:						
	bright	0	0	0	0	0	0	0	0	0	0	0	0	0	0	0	1	1	1	1	1	0	1	0	
Blue	0	0	0	0	0	0	0	0	0	0	0	0	0	0	0	1	1	1	1	1	0	1	1		
	Blue	0	0	0	0	0	0	0	0	0	0	0	0	0	0	1	1	1	1	1	1	x	x		

Note1: X means 0 or 1.

4.6.3 262,144 colors

This product can display 262,144 colors with 64 gray scales by combination ②.

(See "4.6.1 Combinations of input data signals and FRC signal".)

Also the relation between display colors and input data signals is as follows.

Display colors		Data signal (0: Low level, 1: High level)																	
		R5	R4	R3	R2	R1	R0	G5	G4	G3	G2	G1	G0	B5	B4	B3	B2	B1	B0
Basic colors	Black	0	0	0	0	0	0	0	0	0	0	0	0	0	0	0	0	0	0
	Blue	0	0	0	0	0	0	0	0	0	0	0	0	1	1	1	1	1	1
	Red	1	1	1	1	1	1	0	0	0	0	0	0	0	0	0	0	0	0
	Magenta	1	1	1	1	1	1	0	0	0	0	0	0	1	1	1	1	1	1
	Green	0	0	0	0	0	0	1	1	1	1	1	1	0	0	0	0	0	0
	Cyan	0	0	0	0	0	0	1	1	1	1	1	1	1	1	1	1	1	1
	Yellow	1	1	1	1	1	1	1	1	1	1	1	1	0	0	0	0	0	0
	White	1	1	1	1	1	1	1	1	1	1	1	1	1	1	1	1	1	1
Red gray scale	Black	0	0	0	0	0	0	0	0	0	0	0	0	0	0	0	0	0	0
	dark	0	0	0	0	0	1	0	0	0	0	0	0	0	0	0	0	0	0
	↑																		
	↓																		
	bright	1	1	1	1	0	1	0	0	0	0	0	0	0	0	0	0	0	0
	Red	1	1	1	1	1	1	0	0	0	0	0	0	0	0	0	0	0	0
Green gray scale	Black	0	0	0	0	0	0	0	0	0	0	0	0	0	0	0	0	0	0
	dark	0	0	0	0	0	0	0	0	0	0	1	0	0	0	0	0	0	0
	↑																		
	↓																		
	bright	0	0	0	0	0	0	1	1	1	1	0	1	0	0	0	0	0	0
	Green	0	0	0	0	0	0	1	1	1	1	1	1	0	0	0	0	0	0
Blue gray scale	Black	0	0	0	0	0	0	0	0	0	0	0	0	0	0	0	0	0	0
	dark	0	0	0	0	0	0	0	0	0	0	0	0	0	0	0	0	1	0
	↑																		
	↓																		
	bright	0	0	0	0	0	0	0	0	0	0	0	0	1	1	1	1	0	1
	Blue	0	0	0	0	0	0	0	0	0	0	0	0	1	1	1	1	1	1

4.7 DISPLAY POSITIONS

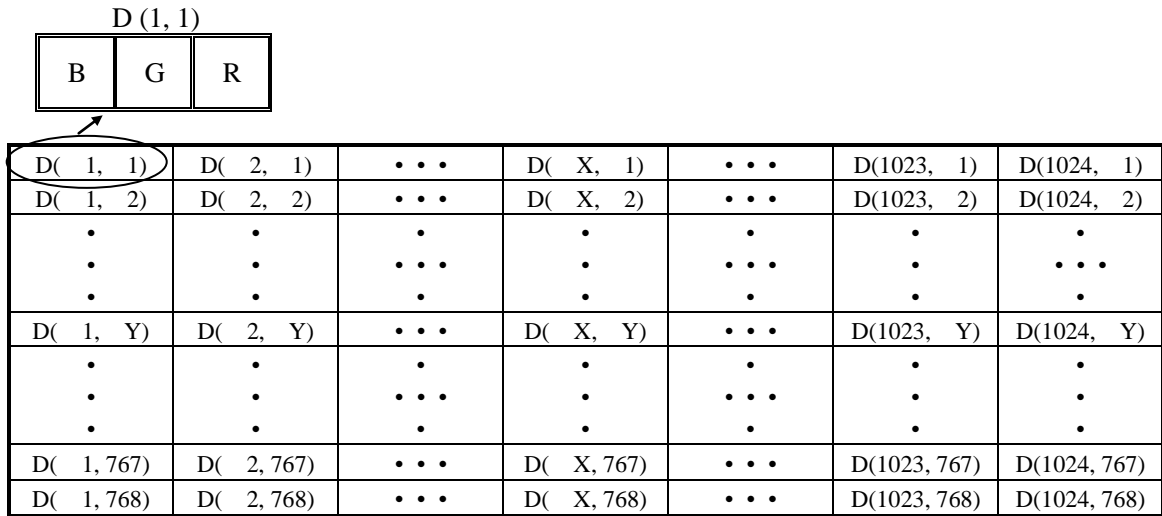

Note1: See "4.8 SCANNING DIRECTIONS".

4.8 SCANNING DIRECTIONS

The following figures are seen from a front view.

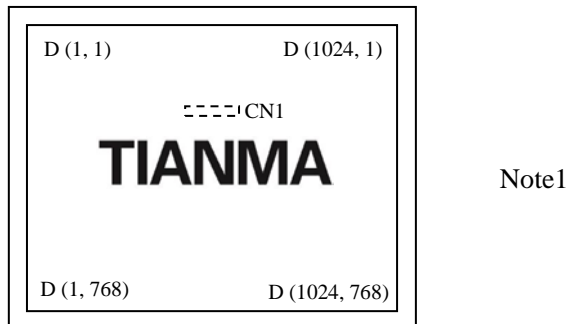

Figure1. Normal scan (DPS: Low or Open)

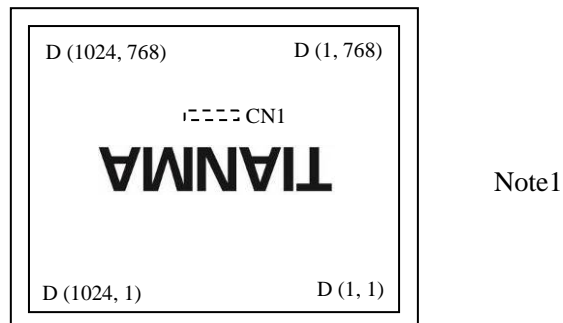

Figure2. Reverse scan (DPS: High)

Note1: Meaning of D (X, Y)
Input data signals for LCD panel signal processing board

4.9 INPUT SIGNAL TIMINGS

4.9.1 Outline of input signal timings

- Horizontal signal

Note1

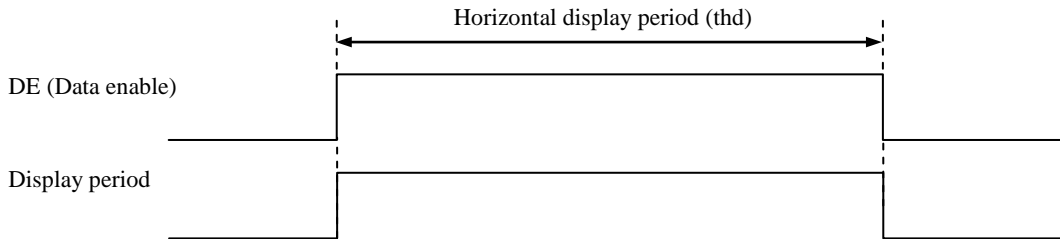

- Vertical signal

Note1

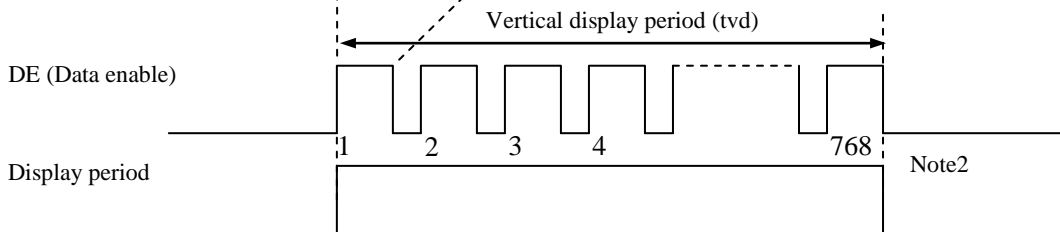

Note1: This diagram indicates virtual signal for set up to timing.

Note2: See "4.9.3 Input signal timing chart" for the pulse number.

4.9.2 Timing characteristics

(Note1, Note2, Note3)

Parameter		Symbol	min.	typ.	max.	Unit	Remarks	
CLK	Frequency	1/tc	52.0	65.0	71.0	MHz	15.385ns (typ.)	
	Duty ratio	-	-			-	-	
	Rise time, Fall time	-				ns		
DATA	CLK-DATA	Setup time	-			ns	-	
		Hold time				ns		
	Rise time, Fall time	-				ns		
DE	Horizontal	Cycle	th	16.542	20.677	26.88	μs	48.363kHz (typ.)
		Display period	thd	1,114	1,344	1,400	CLK	
	Vertical (One frame)	Cycle	tv	13.34	16.666	20.0	ms	60.0Hz (typ.)
			Display period	tvd	780	806	845	
		Display period	tvd	768			H	-
	CLK-DE	Setup time	-	-			ns	-
		Hold time	-				ns	
Rise time, Fall time		-				ns		

☆

Note1: Definition of parameters is as follows.

$$tc = 1CLK, th = 1H$$

Note2: See the data sheet of LVDS transmitter.

Note3: Vertical cycle (tv) should be specified in integral multiple of Horizontal cycle (th).

4.9.3 Input signal timing chart

Horizontal timing

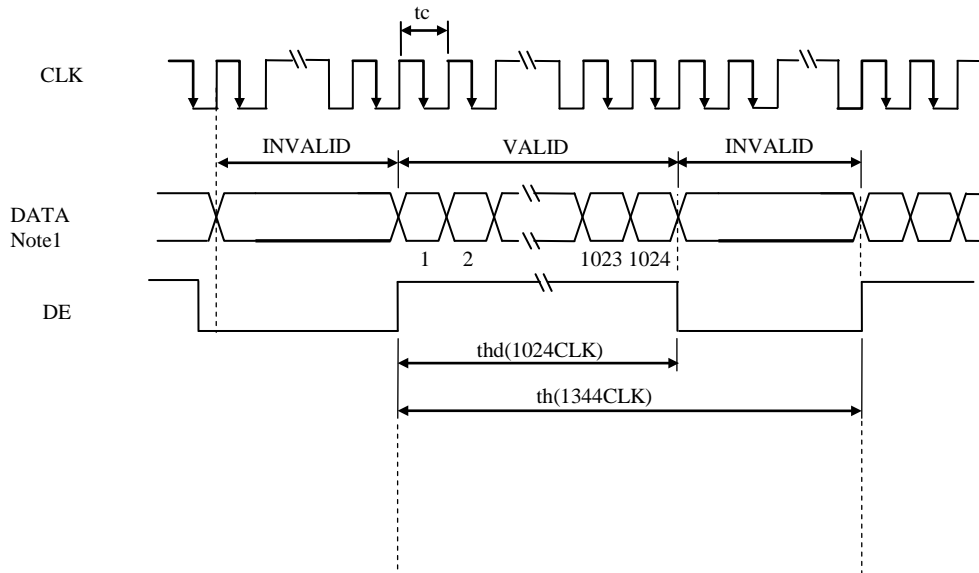

Vertical timing

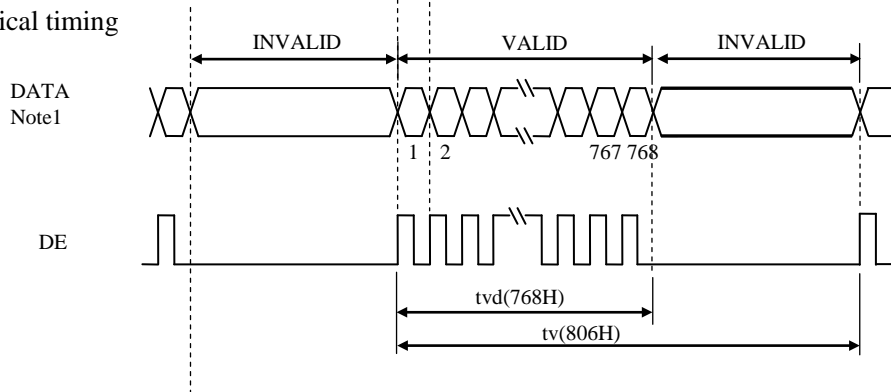

Note1: DATA = R0-R7, G0-G7, B0-B7 or R0-R5, G0-G5, B0-B5

4.10 LVDS Rx AC SPEC

Symbol	Parameter	min.	typ.	max.	Units
t_{RCIP}	CK_+ Period	14.09	-	19.23	ns
t_{RCH}	CK_+ High pulse width	-	$\frac{4}{7} t_{RCIP}$	-	ns
t_{RCL}	CK_+ Low pulse width	-	$\frac{3}{7} t_{RCIP}$	-	ns
t_{RMG}	Receiver Data Input Margin	-0.27	-	0.4	ns
t_{RIP1}	Input Data Position0	$- t_{RMG} $	0.0	$+ t_{RMG} $	ns
t_{RIP0}	Input Data Position1	$\frac{t_{RCIP}}{7} - t_{RMG} $	$\frac{t_{RCIP}}{7}$	$\frac{t_{RCIP}}{7} + t_{RMG} $	ns
t_{RIP6}	Input Data Position2	$2\frac{t_{RCIP}}{7} - t_{RMG} $	$2\frac{t_{RCIP}}{7}$	$2\frac{t_{RCIP}}{7} + t_{RMG} $	ns
t_{RIP5}	Input Data Position3	$3\frac{t_{RCIP}}{7} - t_{RMG} $	$3\frac{t_{RCIP}}{7}$	$3\frac{t_{RCIP}}{7} + t_{RMG} $	ns
t_{RIP4}	Input Data Position4	$4\frac{t_{RCIP}}{7} - t_{RMG} $	$4\frac{t_{RCIP}}{7}$	$4\frac{t_{RCIP}}{7} + t_{RMG} $	ns
t_{RIP3}	Input Data Position5	$5\frac{t_{RCIP}}{7} - t_{RMG} $	$5\frac{t_{RCIP}}{7}$	$5\frac{t_{RCIP}}{7} + t_{RMG} $	ns
t_{RIP2}	Input Data Position6	$6\frac{t_{RCIP}}{7} - t_{RMG} $	$6\frac{t_{RCIP}}{7}$	$6\frac{t_{RCIP}}{7} + t_{RMG} $	ns

☆

☆

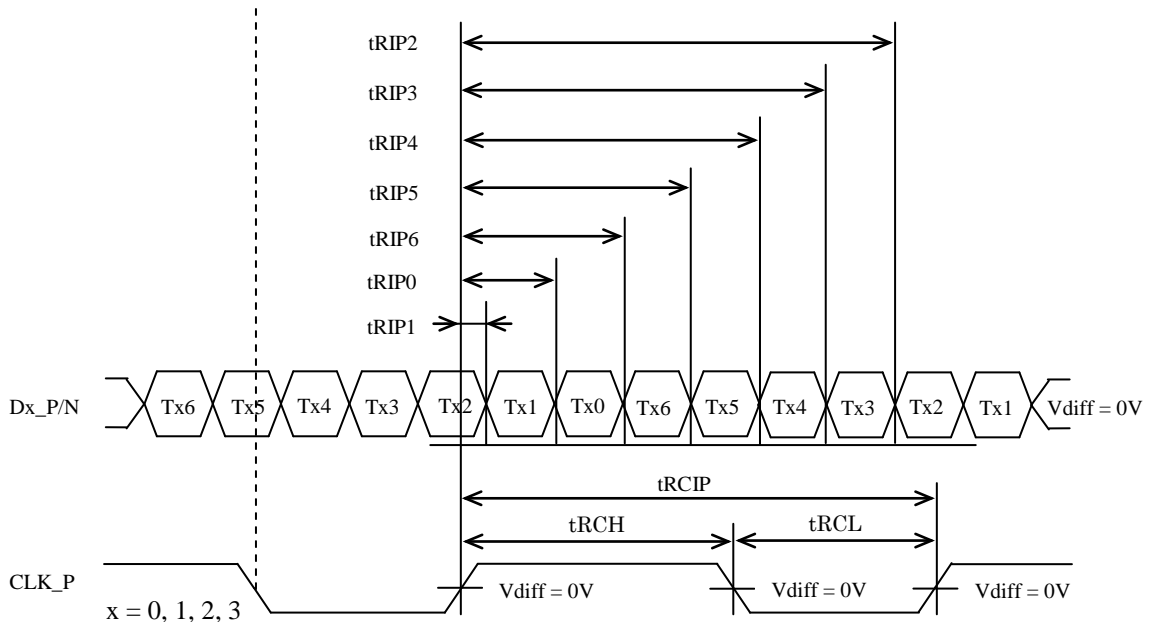

☆

4.11 OPTICS

4.11.1 Optical characteristics

(Note1, Note2)

Parameter	Condition	Symbol	min.	typ.	max.	Unit	Measuring instrument	Remarks	
Luminance	White at center $\theta R=0^\circ, \theta L=0^\circ, \theta U=0^\circ, \theta D=0^\circ$	L	350	500	-	cd/m ²	BM-5A or equivalent	-	
Contrast ratio	White/Black at center $\theta R=0^\circ, \theta L=0^\circ, \theta U=0^\circ, \theta D=0^\circ$	CR	600	1,000	-	-	BM-5A or equivalent	Note3	
Luminance uniformity	White $\theta R=0^\circ, \theta L=0^\circ, \theta U=0^\circ, \theta D=0^\circ$	LU	-	1.25	1.40	-	BM-5A or equivalent	Note4	
Chromaticity	White	x coordinate	W _x	0.263	0.313	0.363	-	SR-3 or equivalent	Note5
		y coordinate	W _y	0.279	0.329	0.379	-		
	Red	x coordinate	R _x	-	0.615	-	-		
		y coordinate	R _y	-	0.337	-	-		
	Green	x coordinate	G _x	-	0.334	-	-		
		y coordinate	G _y	-	0.608	-	-		
Blue	x coordinate	B _x	-	0.157	-	-			
	y coordinate	B _y	-	0.080	-	-			
Color gamut	$\theta R=0^\circ, \theta L=0^\circ, \theta U=0^\circ, \theta D=0^\circ$ at center, against NTSC color space	C	55	60	-	%			
Response time	White to Black	T _{on}	-	3	5	ms	BM-5A or equivalent	Note6	
	Black to White	T _{off}	-	5	8	ms		Note7	
Viewing angle	Right	$\theta U=0^\circ, \theta D=0^\circ, CR \geq 10$	θR	70	80	-	EZ Contrast	Note8	
	Left	$\theta U=0^\circ, \theta D=0^\circ, CR \geq 10$	θL	70	80	-			
	Up	$\theta R=0^\circ, \theta L=0^\circ, CR \geq 10$	θU	70	80	-			
	Down	$\theta R=0^\circ, \theta L=0^\circ, CR \geq 10$	θD	70	80	-			

Note1: These are initial characteristics.

Note2: Measurement conditions are as follows.

T_a= 25°C, VCC= 3.3V, VDD= 12.0V, PWM duty ratio: 100%,

Display mode: XGA, Horizontal cycle= 1/48.363kHz, Vertical cycle= 1/60.0Hz,

DPS= Low or Open: Normal scan, FRC= High or Open (8-bit mode)

Optical characteristics are measured at luminance saturation 20minutes after the product works in the dark room. Also measurement methods are as follows.

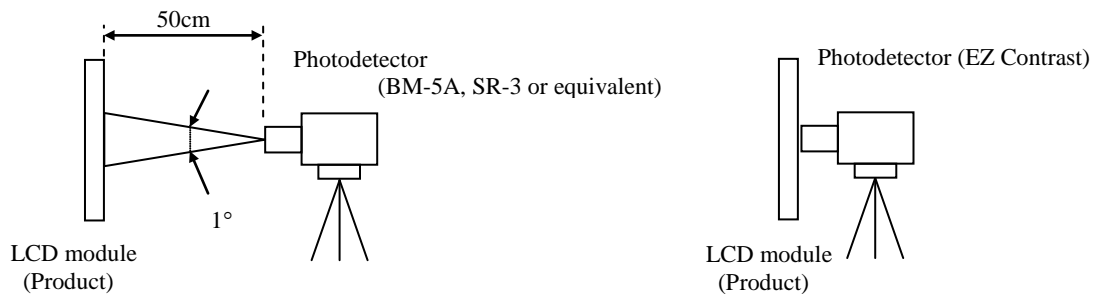

Note3: See "4.11.2 Definition of contrast ratio".

Note4: See "4.11.3 Definition of luminance uniformity".

Note5: These coordinates are found on CIE 1931 chromaticity diagram.

Note6: Product surface temperature: TopF= 30°C

Note7: See "4.11.4 Definition of response times".

Note8: See "4.11.5 Definition of viewing angles".



4.11.2 Definition of contrast ratio

The contrast ratio is calculated by using the following formula.

$$\text{Contrast ratio (CR)} = \frac{\text{Luminance of white screen}}{\text{Luminance of black screen}}$$

4.11.3 Definition of luminance uniformity

The luminance uniformity is calculated by using following formula.

$$\text{Luminance uniformity (LU)} = \frac{\text{Maximum luminance from ① to ⑨}}{\text{Minimum luminance from ① to ⑨}}$$

The luminance is measured at near the 9 points shown below.

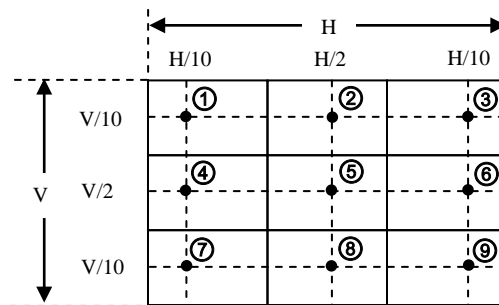

4.11.4 Definition of response times

Response time is measured at the time when the luminance changes from "white" to "black", or "black" to "white" on the same screen point, by photo-detector. Ton is the time when the luminance changes from 90% down to 10%. Also Toff is the time when the luminance changes from 10% up to 90% (See the following diagram.).

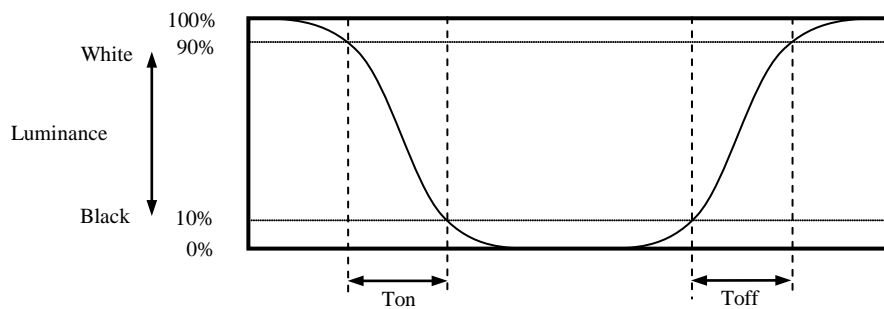

4.11.5 Definition of viewing angles

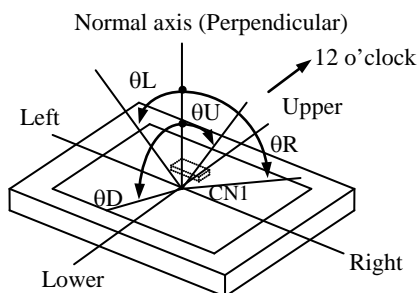

5. ESTIMATED LUMINANCE LIFETIME

The luminance lifetime is the time from initial luminance to half-luminance.

This lifetime is the estimated value, and is not guarantee value.

Condition		Estimated luminance lifetime (Life time expectancy) Note1, Note2, Note3	Unit
LED elementary substance	25°C (Ambient temperature of the product) Continuous operation, PWM duty ratio: 100%	50,000	h
	70°C (Temperature of LCD panel surface and rear shield surface) Continuous operation, PWM duty ratio: 100%	40,000	h

☆

Note1: Life time expectancy is mean time to half-luminance.

Note2: Estimated luminance lifetime is not the value for LCD module but the value for LED elementary substance.

Note3: By ambient temperature, the lifetime changes particularly. Especially, in case the product works under high temperature environment, the lifetime becomes short.

6. RELIABILITY TESTS

Test item	Condition	Judgment	Note1
High temperature and humidity (Operation)	① +60 ± 2°C, RH= 90%, 240 hours ② Display data is black.	No display malfunctions	
High temperature (Operation)	① +70 ± 3°C, 240 hours ② Display data is black.		
Heat cycle (Operation)	① -20 ± 3°C...1 hour +70 ± 3°C...1 hour ② 50 cycles, 4 hours/cycle ③ Display data is black.		
Thermal shock (Non operation)	① -20 ± 3°C...30 minutes +70 ± 3°C...30 minutes ② 100 cycles, 1 hour/cycle ③ Temperature transition time is within 5 minutes.		
ESD (Operation)	① 150pF, 150Ω, ±10kV ② 9 places on a panel surface Note2 ③ 10 times each place at 1 sec interval		
Vibration (Non operation)	① 5 to 100Hz, 11.76m/s ² ② 1 minute/cycle ③ X, Y, Z directions ④ 50 times each direction	No display malfunctions No physical damages	
Mechanical shock (Non operation)	① 294m/s ² , 11ms ② ±X, ±Y, ±Z directions ③ 3 times each direction		



Note1: Display and appearance are checked under environmental conditions equivalent to the inspection conditions of defect criteria.

Note2: See the following figure for discharge points.

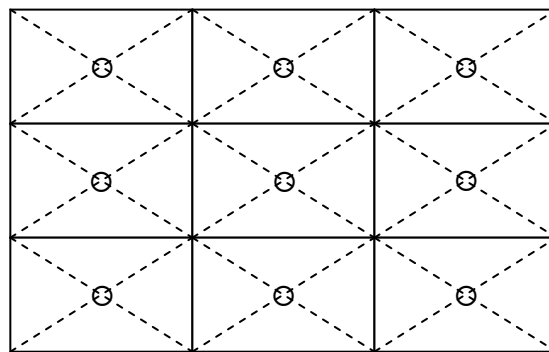

7. PRECAUTIONS

7.1 MEANING OF CAUTION SIGNS

The following caution signs have very important meaning. **Be sure to read "7.2 CAUTIONS" and "7.3 ATTENTIONS"!**



This sign has the meaning that a customer will be injured or the product will sustain damage if the customer practices wrong operations.

7.2 CAUTIONS



*** Do not shock and press the LCD panel and the backlight! There is a danger of breaking, because they are made of glass. (Shock: Equal to or no greater than 294m/s^2 and equal to or no greater than 11ms, Pressure: Equal to or no greater than 19.6N ($\phi 16\text{mm}$ jig))**

7.3 ATTENTIONS



7.3.1 Handling of the product

- ① Take hold of both ends without touching the circuit board when the product (LCD module) is picked up from inner packing box to avoid broken down or misadjustment, because of stress to mounting parts on the circuit board.
- ② Do not hook nor pull cables such as lamp cable, and so on, in order to avoid any damage.
- ③ When the product is put on the table temporarily, display surface must be placed downward.
- ④ When handling the product, take the measures of electrostatic discharge with such as earth band, ionic shower and so on, because the product may be damaged by electrostatic.
- ⑤ The torque for product mounting screws must never exceed $0.230\text{N}\cdot\text{m}$. Higher torque might result in distortion of the bezel. And the length of product mounting screws must be $\leq 2.5\text{mm}$.
- ⑥ The product must be installed using mounting holes without undue stress such as bends or twist (See outline drawings). And do not add undue stress to any portion (such as bezel flat area). Bends or twist described above and undue stress to any portion may cause display mura.
- ⑦ Do not press or rub on the sensitive product surface. When cleaning the product surface, wipe it with a soft dry cloth.
- ⑧ Do not push or pull the interface connectors while the product is working.
- ⑨ When handling the product, use of an original protection sheet on the product surface (polarizer) is recommended for protection of product surface. Adhesive type protection sheet may change color or characteristics of the polarizer.
- ⑩ Usually liquid crystals don't leak through the breakage of glasses because of the surface tension of thin layer and the construction of LCD panel. But, if you contact with liquid crystal by any chance, please wash it away with soap and water.

7.3.2 Environment

- ① Do not operate or store in high temperature, high humidity, dewdrop atmosphere or corrosive gases. Keep the product in packing box with antistatic pouch in room temperature to avoid dusts and sunlight, when storing the product.
- ② In order to prevent dew condensation occurred by temperature difference, the product packing box must be opened after enough time being left under the environment of an unpacking room. Evaluate the storage time sufficiently because dew condensation is affected by the environmental temperature and humidity. (Recommended leaving time: 6 hours or more with the original packing state after a customer receives the package)
- ③ Do not operate in high magnetic field. If not, circuit boards may be broken.
- ④ This product is not designed as radiation hardened.

7.3.3 Characteristics

The following items are neither defects nor failures.

- ① Characteristics of the LCD (such as response time, luminance, color uniformity and so on) may be changed depending on ambient temperature. If the product is stored under condition of low temperature for a long time, it may cause display mura. In this case, the product should be operated after enough time being left under condition of operating temperature.
- ② Display mura, flickering, vertical streams or tiny spots may be observed depending on display patterns.
- ③ Do not display the fixed pattern for a long time because it may cause image sticking. Use a screen saver, if the fixed pattern is displayed on the screen.
- ④ The display color may be changed depending on viewing angle because of the use of condenser sheet in the backlight.
- ⑤ Optical characteristics may be changed depending on input signal timings.
- ⑥ The interference noise between input signal frequency for this product's signal processing board and luminance control frequency of backlight driving circuit may appear on a display. Set up luminance control frequency of backlight driving circuit so that the interference noise does not appear.

☆

7.3.4 Others

- ① All GND, VCC and VDD terminals should be used without any non-connected lines.
- ② Do not disassemble a product or adjust variable resistors.
- ③ See "REPLACEMENT MANUAL FOR LAMP HOLDER SET", when replacing lamp holder set.
- ④ Pack the product with original shipping package, in order to avoid any damages during transportation, when returning the product to TMJ.
- ⑤ The information of China RoHS (II) six hazardous substances or elements in this product is as follows.

☆

China RoHS (II) six hazardous substances or elements					
Lead (Pb)	Mercury (Hg)	Cadmium (Cd)	Hexavalent Chromium (Cr VI)	Polybrominated Biphenyls (PBB)	Polybrominated Biphenyl Ethers (PBDE)
×	○	○	○	○	○

Note1: ○: This indicates that the poisonous or harmful material in all the homogeneous materials for this part is equal or below the limitation level of GB/T26572-2011 standard regulation.

×: This indicates that the poisonous or harmful material in all the homogeneous materials for this part is above the limitation level of GB/T26572-2011 standard regulation.

8. OUTLINE DRAWINGS

8.1 FRONT VIEW

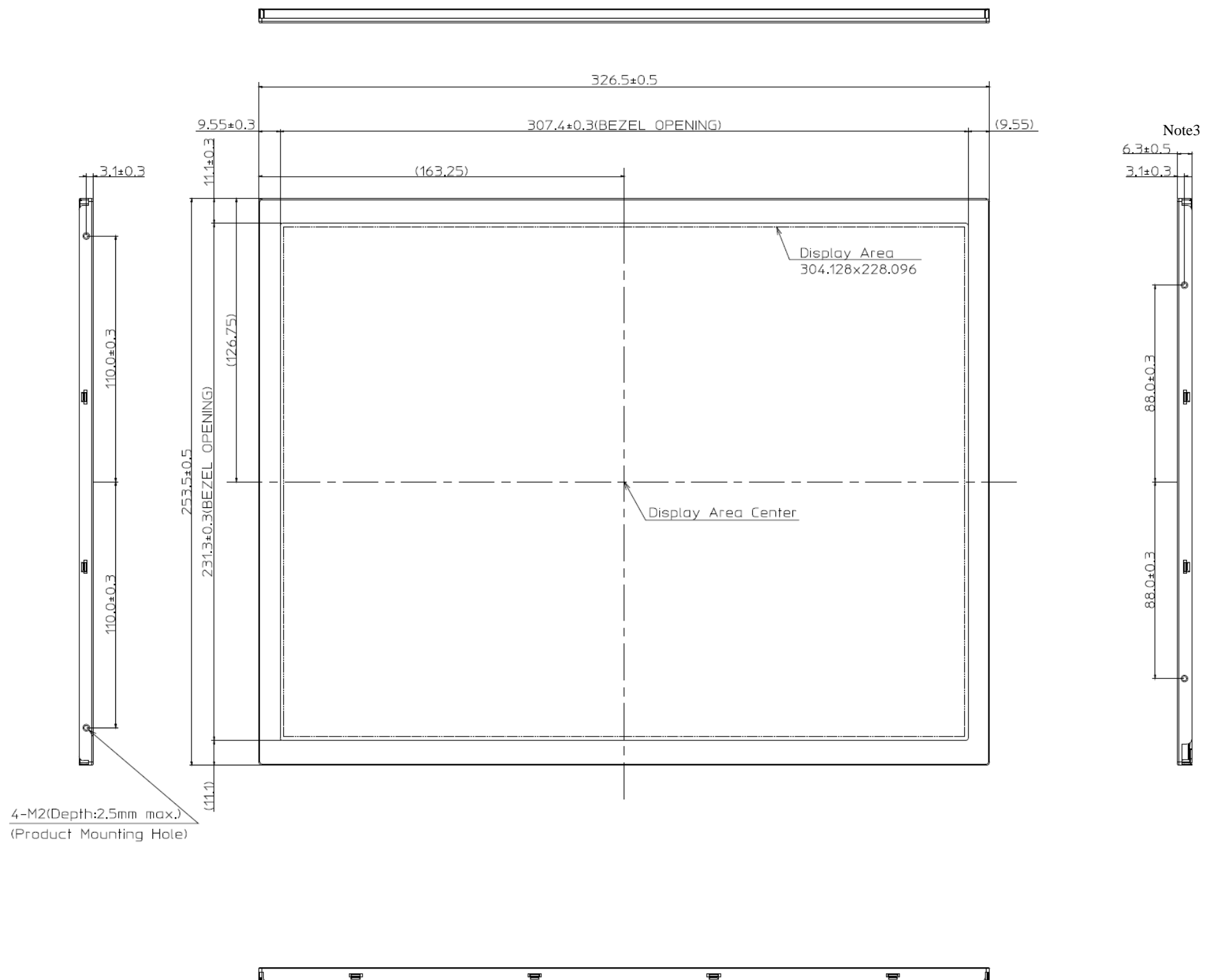

Note1: The values in parentheses are for reference.

Note2: The torque for product mounting screws must never exceed 0.230N·m. And the length of product mounting screws must be ≤ 2.5 mm.

Note3: Excluding a bulge of the FPC

Unit: mm

8.2 REAR VIEW

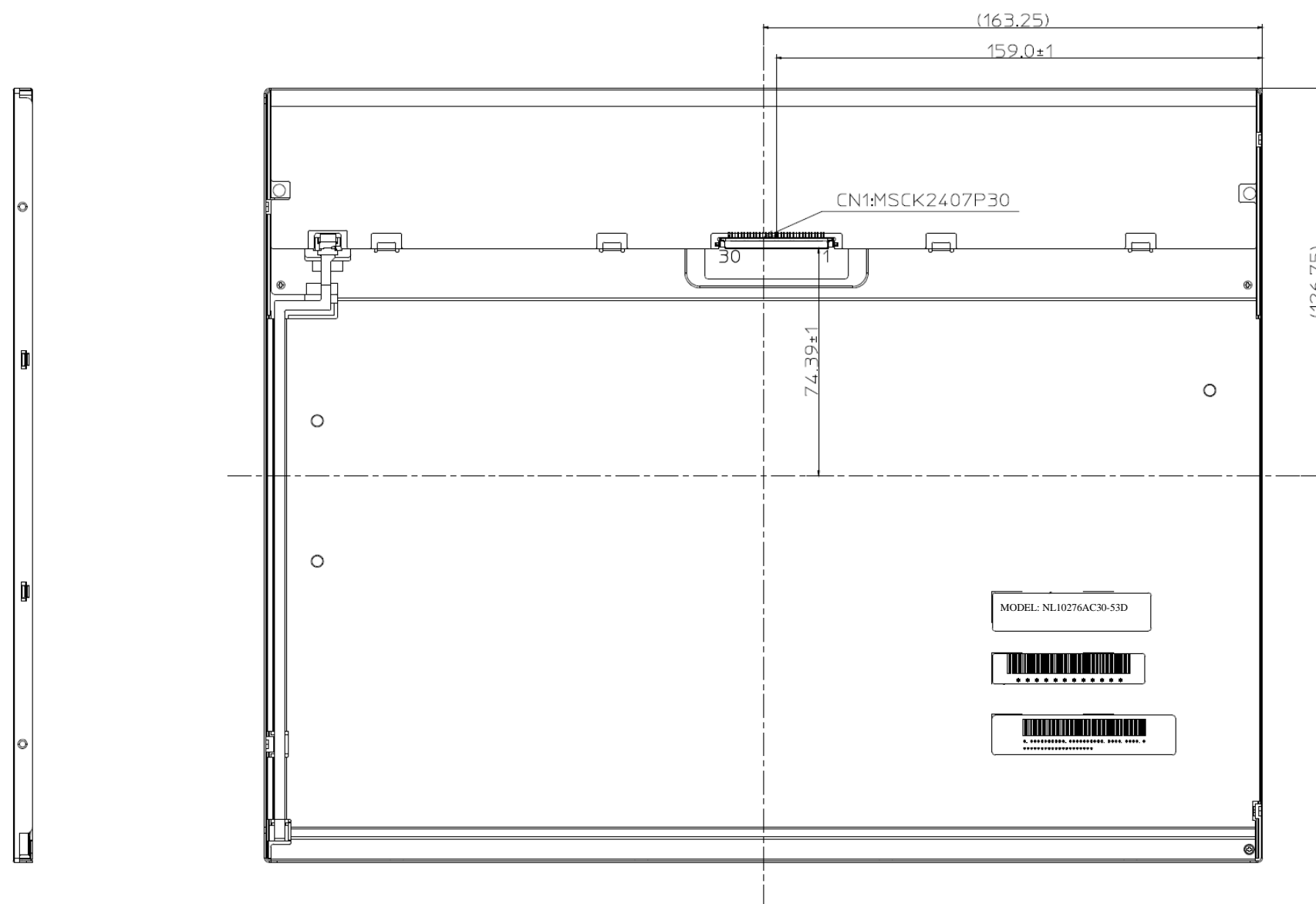

Note1: The values in parentheses are for reference.

Unit: mm

Our company network supports you worldwide with offices in Germany, Austria, Switzerland, the UK and the USA. For more information please contact:

Headquarters

Germany



FORTEC Elektronik AG

Lechwiesenstr. 9
86899 Landsberg am Lech

Phone: +49 8191 91172-0
E-Mail: sales@forteca.de
Internet: www.forteca.de

Fortec Group Members

Austria



FORTEC Elektronik AG

Office Vienna

Nuschinggasse 12
1230 Wien

Phone: +43 1 8673492-0
E-Mail: office@fortec.at
Internet: www.fortec.at

Germany



Distec GmbH

Augsburger Str. 2b
82110 Germering

Phone: +49 89 894363-0
E-Mail: info@distec.de
Internet: www.distec.de

Switzerland



ALTRAC AG

Bahnhofstraße 3
5436 Würenlos

Phone: +41 44 7446111
E-Mail: info@altrac.ch
Internet: www.altrac.ch

United Kingdom



Display Technology Ltd.

Osprey House, 1 Osprey Court
Hichingbrooke Business Park
Huntingdon, Cambridgeshire, PE29 6FN

Phone: +44 1480 411600
E-Mail: info@displaytechnology.co.uk
Internet: www.displaytechnology.co.uk

USA



Apollo Display Technologies, Corp.

87 Raynor Avenue,
Unit 1 Ronkonkoma,
NY 11779

Phone: +1 631 5804360
E-Mail: info@apolloDisplays.com
Internet: www.apolloDisplays.com