



OUR GLOBAL  
COMPETENCE  
CENTRES

 APOLLO DISPLAY  
TECHNOLOGIES



 DISTEC



 DISPLAY  
TECHNOLOGY



# 2D Drawing

## Distec

H; !8 8 &%) \$!5 \$(  
&%) ””k ]XY PCAP Touch Foil  
COF, USB`UbX`=7`Interface

VUËËJËGJG

Copying of this document and giving to others and the use or communication of the contents thereof are forbidden without express authority. Offenders are liable to the payment of damages. All rights are reserved in the event of the grant of a patent or registration of utility model or design.

Die Weitergabe sowie Vervielfältigung dieser Unterlagen und Mitteilung ihres Inhalts ist nicht gestattet, soweit nicht ausdrücklich zugestanden. Zuwiderhandlungen verpflichten zu Schadenersatz. Alle Rechte für den Fall der Patentverletzung oder GM-Entragung vorbehalten.

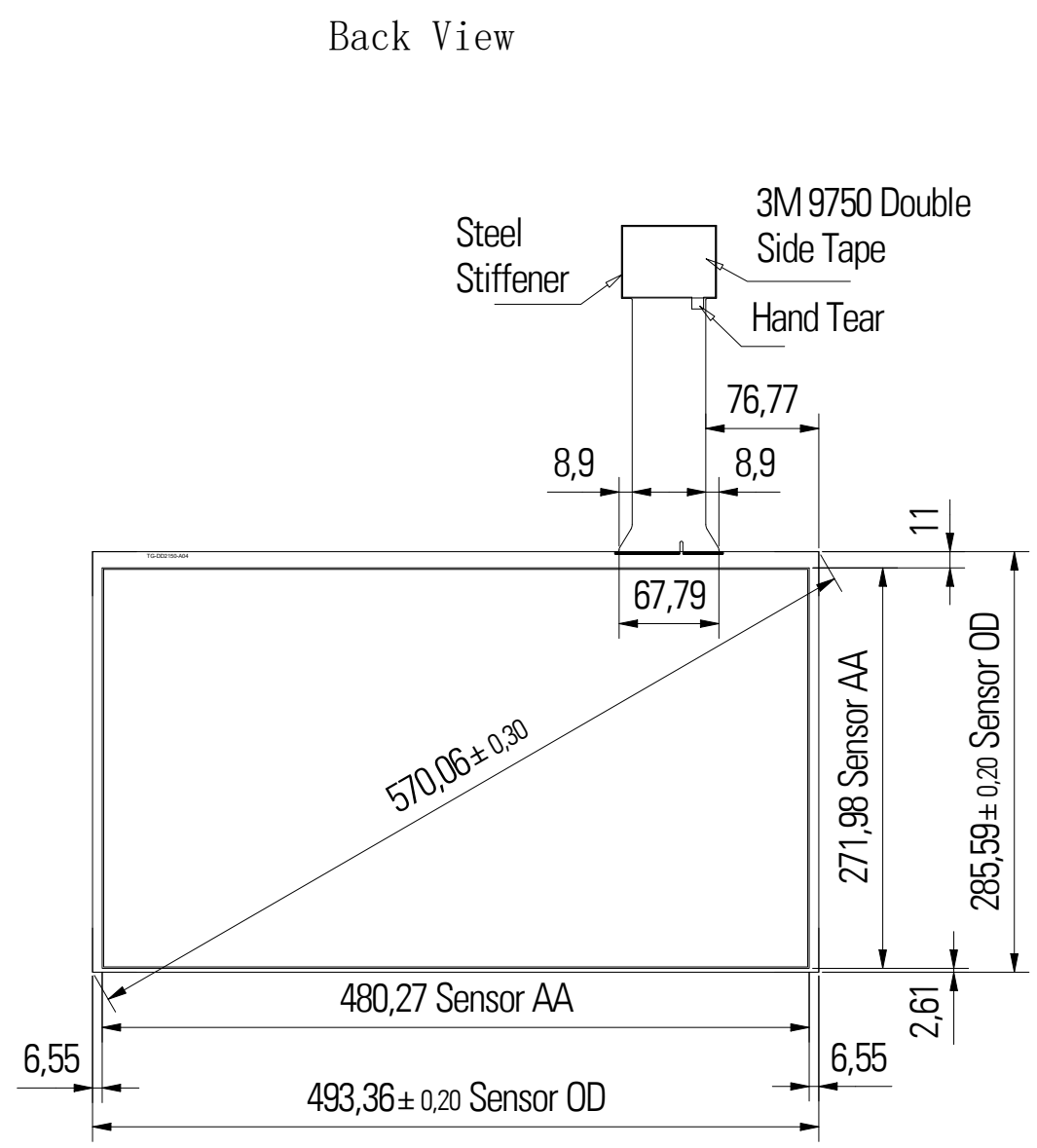
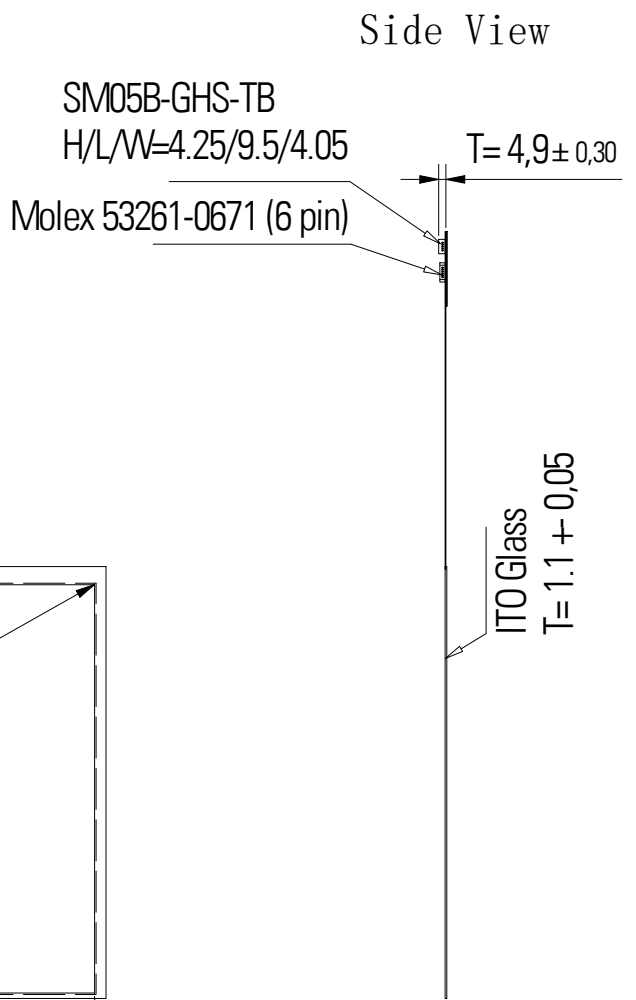
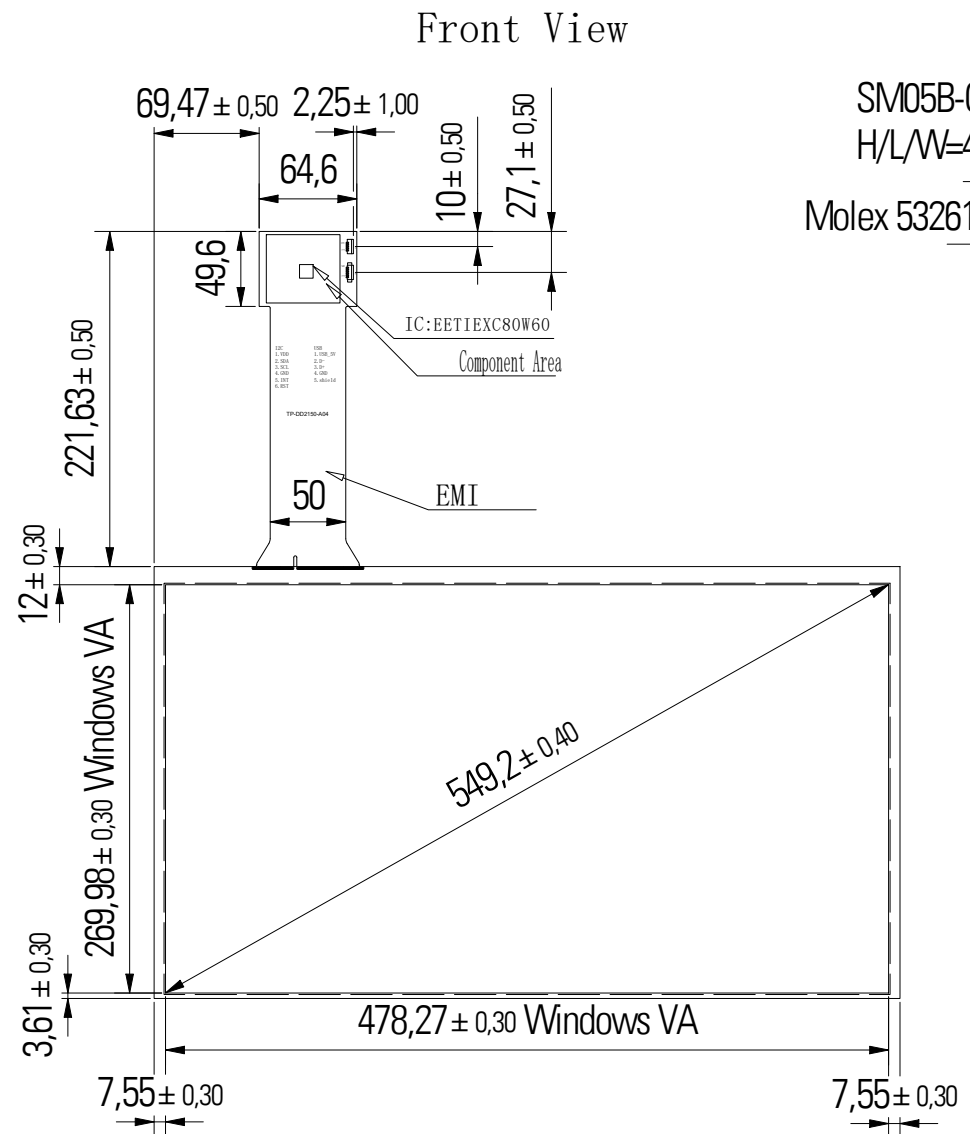

- Specification:**
1. ITO Glass
  2. IC:EETI EXC80w60
  3. Working Voltage: I2C 3.3V USB 5V
  4. Working Temperature: -20°C ~ +70°C
  5. Working Humidity 0% to 90%
  6. Storage Temperature: -20°C to +80°C
  7. Storage Humidity: 0% to 90%
  8. Without individual tolerance: ±0.2mm
  9. Sensor Type: ITO Glass
  10. Channel: RX60/TX34 pitch: RX8.0/TX8.0

Qualitätsvereinbarung nach „Spezifikation techn. Gläser\_V01“  
Quality agreement regarding „Spezifikation technical glasses\_V01“

USB Interface		I2C Interface	
Pin	Signal	Pin	Signal
1	USB_5V	1	VDD
2	D-	2	SDA
3	D+	3	SCL
4	GND	4	GND
5	GND	5	INT
6	Shield	6	RST

Art. Nr.: PART NO.: TO-09-292	Projektionsmethode: 1ST ANGLE PROJECTION	Werstückkanten / WORK PIECE EDGES: DIN ISO 13715	Massenheit: DIMENSION: mm	Maßstab: SCALE:	Gewicht: WEIGHT: 0,00 kg
Zulässige Abweichung: GENERAL LIMITS: DIN ISO 2768 - m K			Material / MATERIAL Allgemein, t=		
Oberfläche: SURFACE:	Datum / DATE: 30.08.2021	Name / NAME: C. Eckardt	Beschreibung / DESCRIPTION TG-DD2150-A04 21.5,PCAP,COF,USB,I2C		
	Gezeichnet DESIGN		Zeichnungsnummer / DRAWING NUMBER TO-09-292_000		
	Kontrolliert CHECKED		Blatt SHEET 1		
	Freigegeben APPROVED		von OF 1		
	Ausgabe EDITION	C. Eckardt	A3		
000	Erstausgabe / 1ST ISSUE	30.08.2021	SR		
Status: STATUS	Änderungen CHANGES		Datum DATE	Name	
			Distec GmbH Augsburger Str. 2b 82110 Germering	Tel.: +49 (89) 894363-0	Ersatz für: REPLM. FOR
					Ersatz durch: REPLACED BY



Our company network supports you worldwide with offices in Germany, Austria, Switzerland, the UK and the USA. For more information please contact:

## Headquarters

### Germany



#### FORTEC Elektronik AG

Augsburger Str. 2b  
82110 Germering

Phone: +49 89 894450-0  
E-Mail: [info@forteca.de](mailto:info@forteca.de)  
Internet: [www.forteca.de](http://www.forteca.de)

## Fortec Group Members

### Austria



#### Distec GmbH Office Vienna

Nuschinggasse 12  
1230 Wien

Phone: +43 1 8673492-0  
E-Mail: [info@distec.de](mailto:info@distec.de)  
Internet: [www.distec.de](http://www.distec.de)

### Germany



#### Distec GmbH

Augsburger Str. 2b  
82110 Germering

Phone: +49 89 894363-0  
E-Mail: [info@distec.de](mailto:info@distec.de)  
Internet: [www.distec.de](http://www.distec.de)

### Switzerland



#### ALTRAC AG

Bahnhofstraße 3  
5436 Würenlos

Phone: +41 44 7446111  
E-Mail: [info@altrac.ch](mailto:info@altrac.ch)  
Internet: [www.altrac.ch](http://www.altrac.ch)

### United Kingdom



#### Display Technology Ltd.

Osprey House, 1 Osprey Court  
Hichingbrooke Business Park  
Huntingdon, Cambridgeshire, PE29 6FN

Phone: +44 1480 411600  
E-Mail: [info@displaytechnology.co.uk](mailto:info@displaytechnology.co.uk)  
Internet: [www.displaytechnology.co.uk](http://www.displaytechnology.co.uk)

### USA



#### Apollo Display Technologies, Corp.

87 Raynor Avenue,  
Unit 1 Ronkonkoma,  
NY 11779

Phone: +1 631 5804360  
E-Mail: [info@apolloDisplays.com](mailto:info@apolloDisplays.com)  
Internet: [www.apolloDisplays.com](http://www.apolloDisplays.com)